



Designation: **F2170–16** **F2170 – 16a**

# Standard Test Method for Determining Relative Humidity in Concrete Floor Slabs Using in situ Probes<sup>1</sup>

This standard is issued under the fixed designation F2170; the number immediately following the designation indicates the year of original adoption or, in the case of revision, the year of last revision. A number in parentheses indicates the year of last reapproval. A superscript epsilon ( $\epsilon$ ) indicates an editorial change since the last revision or reapproval.

## 1. Scope

1.1 This test method covers the quantitative determination of percent relative humidity in concrete slabs for field or laboratory tests.

1.2 The values stated in inch-pound units are to be regarded as standard. The values given in parentheses are mathematical conversions to SI units that are provided for information only and are not considered standard.

1.3 *This standard does not purport to address all of the safety concerns, if any, associated with its use. It is the responsibility of the user of this standard to establish appropriate safety and health practices and determine the applicability of regulatory limitations prior to use.*

Specific warnings are given in Section 7, 10.3.2, and 10.4.4.

## 2. Referenced Documents

2.1 *ASTM Standards:*<sup>2</sup>

[E104 Practice for Maintaining Constant Relative Humidity by Means of Aqueous Solutions](#)

[E177 Practice for Use of the Terms Precision and Bias in ASTM Test Methods](#)

[F710 Practice for Preparing Concrete Floors to Receive Resilient Flooring](#)

## 3. Terminology

3.1 *Definitions:*

3.1.1 *relative humidity, n*—ratio of the amount of water vapor actually in the air compared to the amount of water vapor required for saturation at that particular temperature and pressure, expressed as a percentage.

3.1.2 *service temperature and relative humidity, n*—average ambient air temperature and relative humidity that typically will be found in a building's occupied spaces during normal use.

## 4. Summary of Test Method

4.1 This test method comprises two procedures for forming holes in concrete into which a relative humidity probe is placed. Procedure A for hardened concrete involves drilling a cylindrical hole in concrete with a rotary hammerdrill, then placing a hollow sleeve to line the hole. Procedure B is an alternative procedure for fresh concrete, which involves forming a cylindrical hole in concrete by placing a hollow cylindrical tube in the formwork, then placing and consolidating concrete around the tube. The liner or tube permits measurement of RH at a specific, well-defined depth in the concrete.

4.2 Methods of probe calibration and factors affecting equilibration are described in Section 8.

## 5. Significance and Use

5.1 Moisture permeating from concrete floor slabs affects the performance of flooring systems such as resilient and textile floor coverings and coatings. Manufacturers of such systems generally require moisture testing to be performed before installation on concrete. Internal relative humidity testing is one such method.

<sup>1</sup> This test method is under the jurisdiction of ASTM Committee F06 on Resilient Floor Coverings and is the direct responsibility of Subcommittee F06.40 on Practices. Current edition approved May 1, 2016/July 1, 2016. Published June 2016/August 2016. Originally approved in 2002. Last previous edition approved in 2014 as F2170-14-16. DOI: 10.1520/F2170-16.10.1520/F2170-16A.

<sup>2</sup> For referenced ASTM standards, visit the ASTM website, www.astm.org, or contact ASTM Customer Service at service@astm.org. For *Annual Book of ASTM Standards* volume information, refer to the standard's Document Summary page on the ASTM website.

5.2 Excessive moisture permeating from floor slabs after installation can cause floor covering system failures such as debonding and deterioration of finish flooring and coatings and microbial growth.

5.3 Moisture test results indicate the moisture condition of the slab only at the time of the test.

## 6. Apparatus

6.1 *Hole Liner*, made of plastic or non-corroding metal. The liner shall have the shape of a hollow right circular cylinder and shall be between 0.37 to 0.75-in. (10 to 20 mm) outside diameter.

6.1.1 The liner shall have a solid sidewall that is open only at the bottom and at the top. Slots, holes, or other penetrations in the sidewall of the liner are not permitted. Two or more deformable circumferential fins located around the exterior circumference near the bottom of the liner shall be provided to create a positive seal against the concrete. The liner shall be of sufficient length to extend from the bottom diameter of the hole to the surface of the concrete. See Fig. 1.

NOTE 1—The purpose of the liner is to isolate the probe from the sidewall of the hole so that moisture only enters into the sensor from a specific depth at the bottom of the hole. The specified diameter range will usually permit the hole to intersect a sufficient volume of cement paste to provide adequate moisture interaction with the sensor for accurate measurement. Smaller diameter holes may intersect only a single aggregate particle at the bottom of the hole and therefore produce inaccurate results. If the user observes that the bottom of the hole is occupied by a single aggregate particle, do not use that hole.

6.2 *Humidity Probe and Digital Meter*—Relative humidity and temperature sensors in cylindrical probe, designed such that when the probe is installed to its full depth within the hole liner, the following geometrical considerations shall be met:

6.2.1 The sensing elements of the probe shall be located within  $0.625 \pm 0.125$  in. ( $15.9 \pm 3$  mm) of the base of the liner and the probe sealed or gasketed within itself and the liner such that the volume of air being measured cannot escape upward beyond  $0.625 \pm 0.125$  in. ( $15.9 \pm 3$  mm) within the probe itself or the liner. See Fig. 2.

6.2.2 Obtain probes from a manufacturer with NIST traceable calibration equal to or better than  $\pm 2$  % relative humidity at 50 % relative humidity and  $\pm 2$  % relative humidity at 90 % relative humidity.

NOTE 2—Calibration by end-users using saturated salt solutions in accordance with Practice E104 is not recommended due to the technical difficulties of maintaining sufficiently accurate reference standards. Checking with salt solutions is an acceptable method of assessing probe performance.

## 7. Hazards

7.1 *Silica and Asbestos Warning*—Do not sand, dry sweep, dry scrape, drill, saw, beadblast, or mechanically chip or pulverize existing resilient flooring, backing, lining felt, paint, asphaltic cutback adhesives, or other adhesives. These products may contain asbestos fibers or crystalline silica. Avoid creating dust. Use of dust collection equipment and appropriate personal protective equipment such as an approved respirator may be required to control worker exposure to respirable crystalline silica produced from drilling concrete. Inhalation of such dust is a cancer and respiratory tract hazard. Smoking by individuals exposed to asbestos fibers greatly increases the risk of serious bodily harm. Unless positively certain that the product is a nonasbestos-containing material, presume that it contain asbestos. Regulations may require that the material be tested to determine asbestos content. The Resilient Floor Covering Institute's (RFCI) recommended work practices for removal of existing resilient floor coverings should be consulted for a defined set of instructions addressed to the task of removing all resilient floor covering structures.<sup>3</sup>

7.2 *Lead Warning*—Certain paints may contain lead. Exposure to excessive amounts of lead dust presents a health hazard. Refer to applicable federal, state, and local laws and guidelines for hazard identification and abatement of lead-based paint published by the U.S. Department of Housing and Urban Development regarding appropriate methods for identifying lead-based paint and removing such paint, and any licensing, certification, and training requirements for persons performing lead abatement work.<sup>4</sup>

7.3 *Wet Concrete Warning*—Contact with wet (unhardened) concrete, mortar, cement, or cement mixtures can cause skin irritation, severe chemical burns, or serious eye damage. Wear waterproof gloves, a long-sleeved shirt, full-length trousers, and proper eye protection when working with these materials. If you have to stand in wet concrete, use waterproof boots that are high

<sup>3</sup> *Recommended Work Practices for Removal of Resilient Floor Coverings*, Resilient Floor Covering Institute, 401 East Jefferson St., Suite 102, Rockville, MD 20850.  
<sup>4</sup> *Lead-Based Paint: Interim Guidelines for Hazard Identification and Abatement in Public and Indian Housing*, U.S. Department of Housing and Urban Development, NTIS Order Number PB91-144311. Available online from www.fedworld.gov.

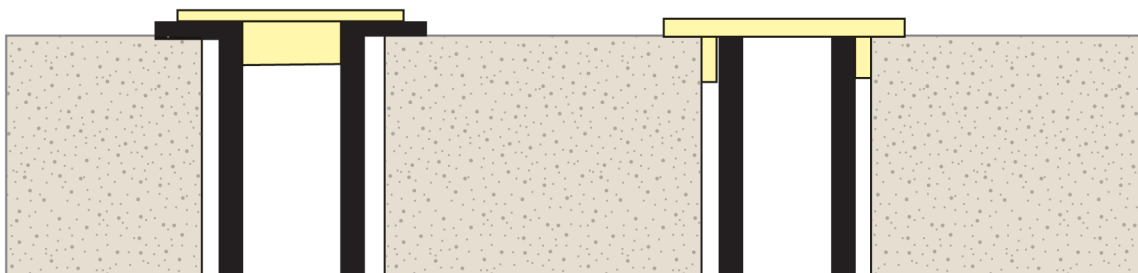

FIG. 1 Example Hole with Liner

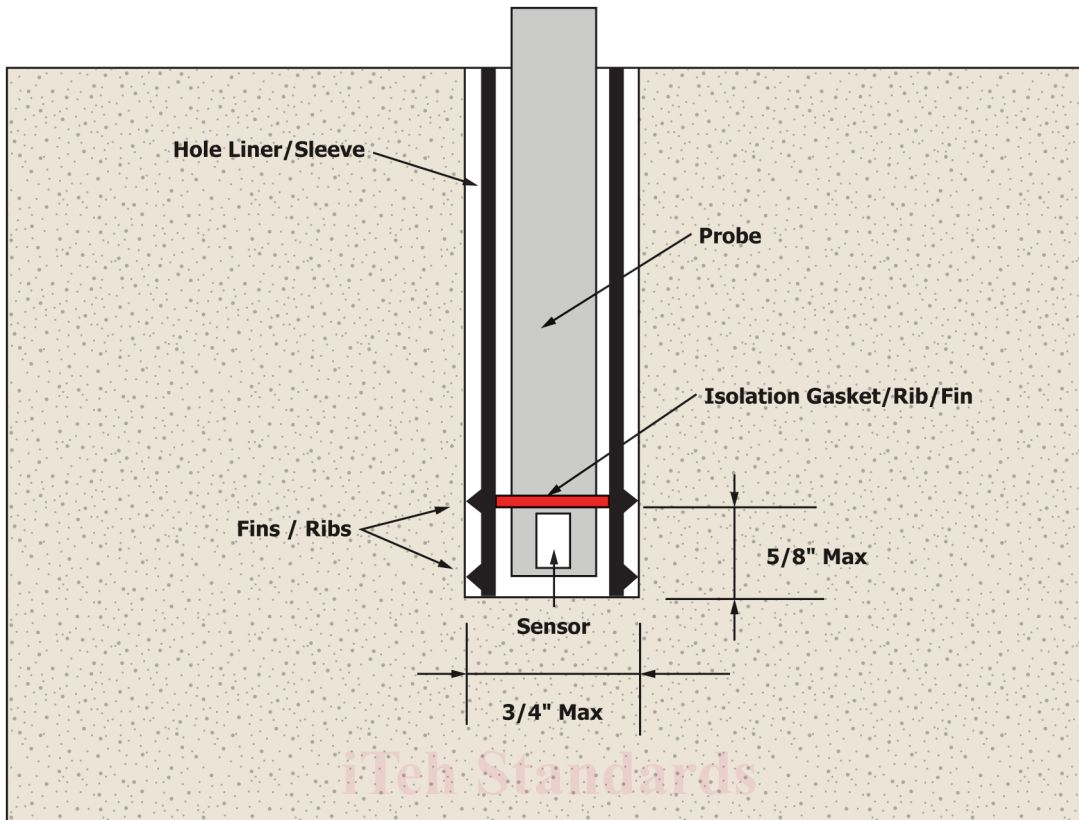

FIG. 2 Example % RH - Probe Element Position

enough to keep concrete from flowing into them. Wash wet concrete, mortar, cement, or cement mixtures from your skin immediately after contact. Indirect contact through clothing can be as serious as direct contact, so promptly rinse out wet concrete, mortar, cement, or cement mixtures from clothing. Seek immediate medical attention if you have persistent or severe discomfort.

## 8. Calibration

8.1 Recalibrate probes at least annually or more frequently if exposed to environmental conditions that affect measurement accuracy.

8.2 Check probe calibration within 30 days before use by the following procedure:

8.2.1 *Calibration Check Procedure, Saturated Salt Solutions*—Prepare saturated salt solutions in accordance with Practice E104. Follow probe manufacturer's recommended procedure for exposing probes. Check probes at relative humidity (RH) equal to or greater than 75 % RH. Record the as-found relative humidity of the probe and the nominal relative humidity of the salt solutions. If the as-found relative humidity differs from the nominal relative humidity by more than 2 % RH (below 90 % relative humidity) or by more than 3 % RH (from 90 to 100 % relative humidity), recalibrate the probe before use or discard.

## 9. Conditioning

9.1 Concrete floor slabs shall be at service temperature and the occupied air space above the floor slab shall be at service temperature and service relative humidity for at least 48 h before making relative humidity measurements in the concrete slab.

## 10. Procedure

10.1 *Number of Tests and Locations:*

10.1.1 Perform three tests for the first 1000 ft<sup>2</sup> (100 m<sup>2</sup>) and at least one additional test for each additional 1000 ft<sup>2</sup> (100 m<sup>2</sup>).

10.1.2 Select test locations to provide information about moisture distribution across the entire concrete floor slab, especially areas of potential high moisture. Include a test location within 1 m (3 ft) of each exterior wall.

10.2 Determine the appropriate depth for probe holes from the following table: