



Designation: ~~E915 – 10~~ E915 – 16

Standard Test Method for Verifying the Alignment of X-Ray Diffraction Instrumentation for Residual Stress Measurement¹

This standard is issued under the fixed designation E915; the number immediately following the designation indicates the year of original adoption or, in the case of revision, the year of last revision. A number in parentheses indicates the year of last reapproval. A superscript epsilon (ϵ) indicates an editorial change since the last revision or reapproval.

1. Scope

1.1 This test method covers the preparation and use of a flat stress-free test specimen for the purpose of checking the systematic error caused by instrument misalignment or sample positioning in X-ray diffraction residual stress measurement, or both.

1.2 This test method is applicable to apparatus intended for X-ray diffraction macroscopic residual stress measurement in polycrystalline samples employing measurement of a diffraction peak position in the high-back reflection region, and in which the θ , 2θ , and ψ rotation axes can be made to coincide (see Fig. 1).

1.3 This test method describes the use of iron powder which has been investigated in round-robin studies for the purpose of verifying the alignment of instrumentation intended for stress measurement in ferritic or martensitic steels. To verify instrument alignment prior to stress measurement in other metallic alloys and ceramics, powder having the same or lower diffraction angle as the material to be measured should be prepared in similar fashion and used to check instrument alignment.

1.4 *This standard does not purport to address all of the safety concerns, if any, associated with its use. It is the responsibility of the user of this standard to establish appropriate safety and health practices and determine the applicability of regulatory limitations prior to use.*

2. Referenced Documents

2.1 *ASTM Standards:*²

~~E4E6 Specification for Woven Wire Test Sieve Cloth and Test Sieves~~ [Terminology Relating to Methods of Mechanical Testing](https://standards.iteh.ai/terminology/terminology-relating-to-methods-of-mechanical-testing)

3. Terminology

3.1 The definitions of mechanical testing terms that appear in Terminology E6 apply to this test method.

3.1.1 In addition, the following common term from Terminology E6 is defined:

3.1.2 *residual stress* [FL^{-2}], n —stress in a body that is at rest and in equilibrium and at uniform temperature in the absence of external and mass forces.

4. Significance and Use

4.1 This test method provides a means of verifying instrument alignment in order to quantify and minimize systematic experimental error in X-ray diffraction residual stress measurement. This method is suitable for application to conventional diffractometers or to X-ray diffraction instrumentation of either the diverging or parallel beam types.^{3, 4}

4.2 Application of this test method requires the use of a flat specimen of stress-free material that produces diffraction in the angular region of the diffraction peak to be used for stress measurement. The specimen must be sufficiently fine-grained and isotropic so that large numbers of individual crystals contribute to the diffraction peak produced. The crystals must provide intense diffraction at all angles of tilt, ψ , which will be employed (see Note 1).

NOTE 1—Complete freedom from preferred orientation in the stressfree specimen is, however, not critical in the application of the technique.

¹ This test method is under the jurisdiction of ASTM Committee E28 on Mechanical Testing and is the direct responsibility of Subcommittee E28.13 on Residual Stress Measurement.

Current edition approved June 1, 2010 Aug. 1, 2016. Published July 2010 August 2016. Originally approved in 1983. Last previous edition approved in 2002 2010 as E915 – 96 (2002) E915 – 10. DOI: 40.1520/E0915-10.10.1520/E0915-16.

² For referenced ASTM standards, visit the ASTM website, www.astm.org, or contact ASTM Customer Service at service@astm.org. For *Annual Book of ASTM Standards* volume information, refer to the standard's Document Summary page on the ASTM website.

³ Hilley, M. E., Larson, J. A., Jateczak, C. F., and Ricklefs, R. E., eds., Residual Stress Measurement by X-ray Diffraction, *SAE J784a*, Society of Automotive Engrs., Inc., Warrendale, PA (1971).

⁴ "Standard Method for X-Ray Stress Measurement," *Committee on Mechanical Behavior of Materials*, The Society of Materials Science, Japan, (20 April 1973).

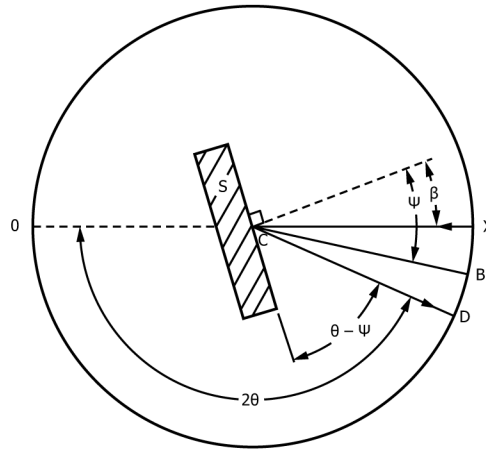

NOTE— The plane of diffraction is the plane of the figure, and:
 X = x-ray source,
 D = receiving slit and detector,
 C = diffractometer center (2θ , θ , ψ axes coincident),
 O = diffractometer zero, $2\theta = 0$ (O, C, X colinear),
 S = sample,
 CN = sample surface normal,
 XC = incident x-ray beam,
 CD = diffracted x-ray beam, and
 CB = incident-diffracted beam bisector.

FIG. 1 X-Ray Diffraction Stress Measurement Geometry and Angles Defined

5. Procedure

5.1 Instrument Alignment:

5.1.1 Align the X-ray diffraction instrumentation to be used for residual stress measurement in accordance with the instructions supplied by the manufacturer. In general, this alignment must achieve the following, whether the θ , 2θ , and ψ axes are variable or fixed (see Fig. 1):

5.1.1.1 The θ , 2θ , and ψ axes shall coincide.

5.1.1.2 The incident X-ray beam shall be centered on the ψ and 2θ axes, within a focusing range, which will conform to the desired error and precision tolerances (see Sections 56 and 67).

5.1.1.3 The X-ray tube focal spot, the ψ and 2θ axes, and the receiving slit positioned at 2θ equals zero degrees shall be on a line in the plane of diffraction. Alternatively, for instrumentation limited to the back reflection region, the diffraction angle 2θ shall be calibrated.

5.1.1.4 The proper sample position shall be established, using whatever means are provided with the instrument, such that the surface of the sample is positioned at the θ and ψ axes, within the focal distance range which will conform to the desired error and precision tolerances (see Sections 56 and 67).

5.1.1.5 The angle ψ must be determined accurately. (see Note 5)

5.2 X-Ray Optics:

5.2.1 Appropriate X-ray peak selection should be made at the highest diffraction angle possible, consistent with peak intensity, and this may include selection of the x-radiation to be used.

5.2.2 When the $K\alpha$ characteristic radiation doublet is used for stress measurement, it is desirable to select incident and receiving X-ray beam optics that will produce maximum separation of the $K\alpha_1 - K\alpha_2$ doublet. Perform stress measurements on the stress-free specimen employing the $K\alpha_1$ diffraction peak at all ψ angles investigated. Because resolution of the $K\alpha$ doublet may vary with the angle ψ , and because some instrumentation may be incapable (due to fixed X-ray optics) of obtaining resolution of the doublet, care must be taken not to resolve the doublet at some ψ angles while blending the doublet into a single peak at other ψ angles.

5.3 Selection of Powder for a Stress-Free Iron Specimen:

5.3.1 Use iron powder with a particle size greater than $1\ \mu\text{m}$ (4×10^{-5} in.) (See Note 2.)

5.3.2 This standard may be applied to other metallic alloys and ceramics (see 1.3).

5.3.3 The reporting of strain instead of stress circumvents the necessity of establishing applicable elastic constants and serves to eliminate a source of uncertainty.

NOTE 2—Annealed armco iron powder of $<45\ \mu\text{m}$ (325 mesh) has been found suitable when using Cr K-alpha x-radiation.

5.3.4 Annealing of the powder in vacuum reduces diffraction peak width, thereby increasing diffraction peak resolution. This is generally desirable (see Note 3). Powders in the form of plastically deformed filings may be used, but will produce broader