



Designation: C857 – 16

Standard Practice for Minimum Structural Design Loading for Underground Precast Concrete Utility Structures¹

This standard is issued under the fixed designation C857; the number immediately following the designation indicates the year of original adoption or, in the case of revision, the year of last revision. A number in parentheses indicates the year of last reapproval. A superscript epsilon (ϵ) indicates an editorial change since the last revision or reapproval.

1. Scope

1.1 This practice describes the minimum live loads and dead loads to be applied when designing monolithic or sectional precast concrete utility structures. Concrete pipe, box culverts, and material covered in Specification C478 are excluded from this practice.

NOTE 1—For additional information see AASHTO Standard Specification for Highway Bridges, Seventeenth Edition.

NOTE 2—The purchaser is cautioned that he must properly correlate the anticipated loading conditions and the field requirements with the design loads used.

1.2 The values stated in inch-pound units are to be regarded as standard. The values given in parentheses are mathematical conversions to SI units that are provided for information only and are not considered standard.

1.3 *This standard does not purport to address all of the safety concerns, if any, associated with its use. It is the responsibility of the user of this standard to establish appropriate safety and health practices and determine the applicability of regulatory limitations prior to use.*

2. Referenced Documents

- 2.1 *ASTM Standards*:²
C478 Specification for Circular Precast Reinforced Concrete Manhole Sections
- 2.2 *AASHTO Standard*:
Specification for Highway Bridges, Seventeenth Edition³

3. Terminology

- 3.1 *Definitions of Terms Specific to This Standard*:

¹ This practice is under the jurisdiction of ASTM Committee C27 on Precast Concrete Products and is the direct responsibility of Subcommittee C27.10 on Utility Structures.

Current edition approved Sept. 1, 2016. Published September 2016. Originally approved in 1978. Last previous edition approved in 2014 as C857 – 14. DOI: 10.1520/C0857-16.

² For referenced ASTM standards, visit the ASTM website, www.astm.org, or contact ASTM Customer Service at service@astm.org. For *Annual Book of ASTM Standards* volume information, refer to the standard's Document Summary page on the ASTM website.

³ Available from American Association of State Highway and Transportation Officials (AASHTO), 444 N. Capitol St., NW, Suite 249, Washington, DC 20001, http://www.transportation.org.

3.1.1 *dead loads*—will consist of any other load that can affect the design of the structure.

3.1.2 *lateral earth loads*—the lateral pressure due to the effective weight of adjacent earth backfill.

3.1.3 *lifting insert*—device embedded or otherwise attached to the structure, designed and manufactured to support a measured, sustained, concentrated load.

3.1.4 *live loads*—will consist of any moving loads that can affect the design of the structure and their associated impact and surcharge loads.

3.1.5 *utility structure*—a structure that is used by electric, gas, communication, or similar industries.

4. Design Loads

4.1 *Roof*—The design loads for the roof of any structure at or below ground level consists of the live loads including impact and dead loads that can develop as a result of earth pressure, hydrostatic pressure, and construction materials such as used for roadways and walkways.

4.1.1 *Live Loads*—The vehicle and pedestrian load designations are given in Table 1. Live load wheel spacing is shown in Fig. 1.

4.1.2 *Impact*:

4.1.2.1 The live loads A-16, A-12, and A-8 shall be increased as follows to sustain the effect of impact:

- 4.1.2.2 *Live Load Increase*:
0 to 12 in. (0 to 305 mm) below ground level, 30 %
13 to 24 in. (330 to 610 mm) below ground level, 20 %
25 to 35 in. (635 to 889 mm) below ground level, 10 %
36 in. (914 mm) or more below ground level, 0 %

4.1.3 *Dead Loads*—Dead loads will consist of the weight of the roof, roadbed, walkways, earth fill, access opening covers, and any other material that produces a static load.

4.1.3.1 Recommended unit weights of materials for design calculations are as follows:

Concrete, plain, and reinforced	150 lb/ft ³ (2043 kg/m ³)
Cast iron	450 lb/ft ³ (7208 kg/m ³)
Steel	490 lb/ft ³ (7850 kg/m ³)
Aluminum	175 lb/ft ³ (2804 kg/m ³)
Earth fill (dry)	110 lb/ft ³ (1762 kg/m ³)
Macadam	140 lb/ft ³ (2243 kg/m ³)

4.1.4 *Distribution of Wheel Loads Through Earth Fills*:

TABLE 1 Vehicle and Pedestrian Load Designations

Designations	Maximum Loads	Uses
A-16 (HS20-44) ^A	16 000 lbf (71 172 N)/wheel	heavy traffic
A-12 (HS15-44) ^A	12 000 lbf (53 376 N)/wheel	medium traffic
A-8 (H10-44) ^A	8 000 lbf (35 586 N)/wheel	light traffic
A-0.3	300 lbf/ft ² (14.4 kPa)	walkways ^B

^AThe designations in parentheses are the corresponding AASHTO designations.
^BAnticipated designs other than those listed should be designated by purchaser.

4.1.4.1 Wheel loads at ground level shall be considered applied to a wheel load area as indicated in Fig. 2.

4.1.4.2 Wheel loads shall be distributed below ground level as a truncated pyramid, as shown in Fig. 3, in which the top surface is the wheel load area and the distributed load area is equal to the following:

$$DLA = (W + 1.75 H)(L + 1.75 H) \quad (1)$$

where:

- DLA = distributed load area, ft²(m²)
- W = wheel load width, ft (m),
- L = wheel load length, ft (m), and
- H = depth of fill, ft (m).

4.1.4.3 When several distributed load areas overlap, the total load shall be considered as uniformly distributed over the area defined by the outside limits of the individual areas as indicated in Fig. 4. When the dimensions of the composite distributed load area exceeds the roof area only that portion of the distributed load on the roof area shall be considered in the design.

4.1.4.4 The distribution of wheel loads through earth fill are neglected when the depth of fill exceeds 8 ft (2.5 m).

4.2 Walls—The design loads for the walls of any structure at or below ground level will consist of surcharge loads resulting from live loads, lateral earth loads that can develop as a result of earth pressure, hydrostatic pressure, and construction materials such as used for roadways and walkways. Load diagrams of live load surcharge and lateral earth loads are shown in Fig. 5.

4.2.1 Live Loads:

4.2.1.1 When traffic can come within a horizontal distance from the structure equal to one half the height of the structure, a live load surcharge pressure of not less than 0.5 % of the wheel loading of the traffic involved shall be taken as the live load acting upon the wall of the structure.

4.2.1.2 Surcharge pressures for various live loads transferred to equivalent horizontal fluid pressure are as follows:

A-16	16 000 lbf wheel load × 0.005 = 80 lbf/ft ² (3830 Pa)
A-12	12 000 lbf wheel load × 0.005 = 60 lbf/ft ² (2873 Pa)
A-8	8 000 lbf wheel load × 0.005 = 40 lbf/ft ² (1915 Pa)
A-0.3	Refer to 4.2.2.1

4.2.1.3 Surcharge pressures resulting from live loads are neglected when the distance from ground level exceeds 8 ft (2.5 m).

4.2.2 Lateral Earth Loads:

4.2.2.1 The lateral earth loads will consist of an earth pressure above ground water level and hydrostatic pressure plus a modified earth pressure below ground water level. The earth pressure above ground water level and the modified earth

pressure below ground water level will be converted to a horizontal pressure using Rankine's Theory on active earth pressure. No structure will be designed for less than a 30 lb/ft² (1436 Pa) horizontal pressure.

4.2.2.2 For the general case when structures are placed in areas where the soil surface does not slope the horizontal pressure acting at a point on the wall of the structure above ground water level will be:

$$P = K_a \times W \times H \quad (2)$$

where:

- P = horizontal pressure, lbf/ft² (Pa)
- K_a = coefficient of active earth pressure = $(1 - \sin \phi)/(1 + \sin \phi)$
- ϕ = angle of internal friction of the soil, deg (rad),
- W = unit weight of soil, lb/ft³ (kg/m³) and
- H = distance from ground level to the point on the wall under consideration, ft (m).

4.2.2.3 In special cases, when structures are placed in areas where the soil surface is sloping, the horizontal pressure acting at a point on the structure above ground water level is as follows:

$$P = \cos \delta K_a W_s H \quad (3)$$

where:

- P = horizontal pressure, lbf/ft² (Pa),
- K_a = coefficient of active earth pressure = $\frac{\cos \delta \cos \delta - \sqrt{\cos^2 \delta - \cos^2 \phi}}{\cos \delta + \sqrt{\cos^2 \delta - \cos^2 \phi}}$
- ϕ = angle of internal friction of the soil, deg (rad),
- δ = angle between the sloping soil surface and the horizontal, deg (rad)
- W_s = unit weight of soil, lb/ft³ (kg/m³), and
- H = distance from ground level to the point on the wall under consideration, ft (m).

The horizontal pressure below ground water level resulting from the weight of soil above ground water level is equal to the horizontal pressure at ground water level and will remain constant from ground water level to the base of structure.

4.2.2.4 The horizontal pressure that can develop below ground water level will consist of a full hydrostatic pressure plus horizontal pressure resulting from the weight of submerged soil. The hydrostatic pressure acting at a point on the wall of the structure below ground water level is:

$$P_w = W_w H_w \quad (5)$$

where:

- P_w = hydrostatic pressure, lbf/ft² (Pa),
- W_w = unit weight of water, lb/ft³ (kg/m³), and
- H_w = distance from ground water level to the point on the wall under consideration, ft (m).

The horizontal pressure acting at a point on the wall of the structure below ground water level resulting from the weight of submerged soil is:

$$P_s = (W_s - W_w) K_a H_w \quad (6)$$

3.1.2.3 LIVE LOAD SPACING

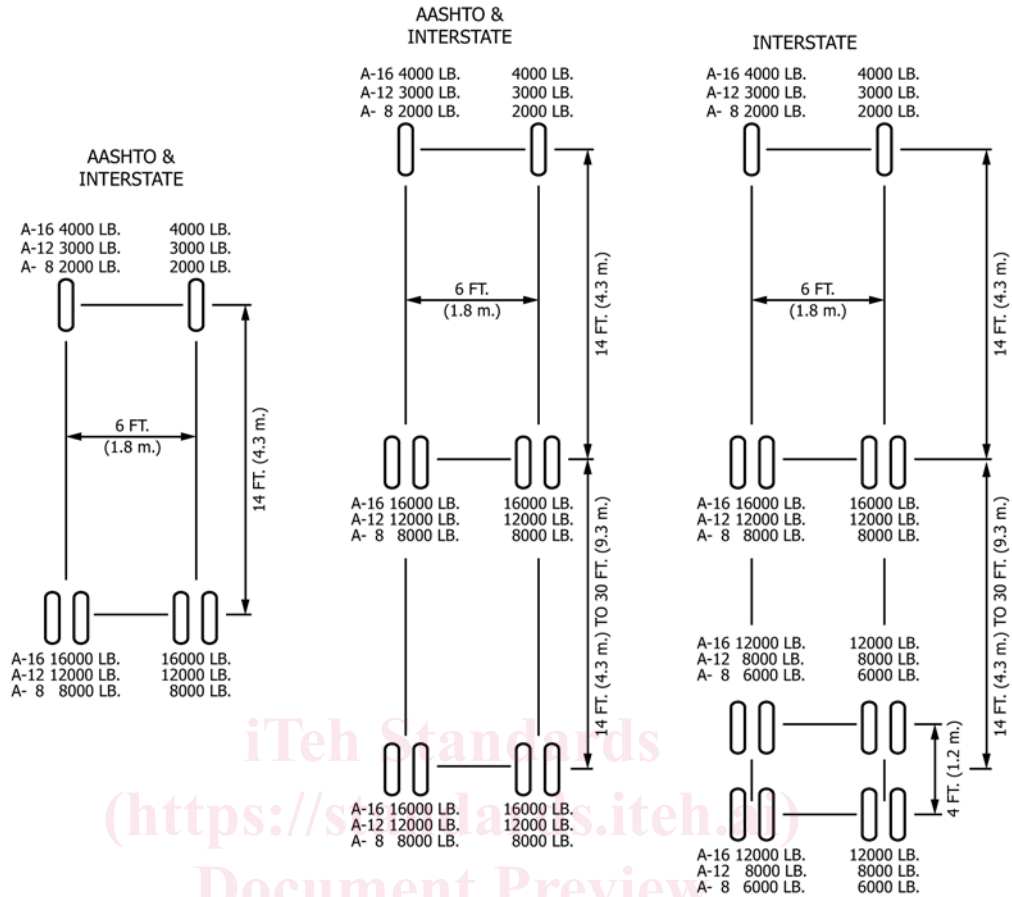

iTeh Standards
 (https://standards.iteh.com)
 Document Preview

ASTM C857-16

https://standards.iteh.ai/catalog/standards/sist/53936322-1910-4d93-9eb1-cd0976a6f7ef/astm-c857-16

2000 LB.	(907.2 kg)
3000 LB.	(1360.8 kg)
4000 LB.	(1814.4 kg)
8000 LB.	(3628.8 kg)
12000 LB.	(5443.2 kg)
16000 LB.	(7257.6 kg)

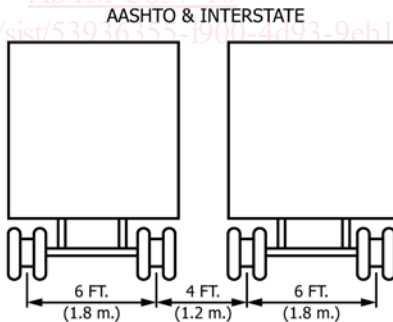

FIG. 1 Live Load Spacing

where:

- P = horizontal pressure from submerged soil, lbf/ft² (Pa)
- $W_s - W_w$ = unit weight of soil less the unit weight of water, lb/ft³ (kg/m³),
- K_a = coefficient of active earth pressure = $(1 - \sin \phi)/(1 + \sin \phi)$,
- ϕ = angle of internal friction of the soil, deg (rad), and
- H_w = distance from ground water level to the point on the wall under consideration, ft (m).

NOTE 3—The coefficient of active earth pressure is used for the general

case where the soil surface does not slope.

4.3 Base:

4.3.1 *Live Loads*—The live loads transmitted to the base consist of the maximum value possible of live loads that can be imposed on the roof. This includes the total number of wheel loads that can simultaneously be placed on the structure.

4.3.2 *Dead Loads*—The dead loads on the base consist of the dead loads imposed on the roof plus the weight of the structure excluding the base, or the hydrostatic pressure acting on the base, whichever is greater.

4.4 *Accessories Loading*: