



Designation: ~~E1530 – 11~~ **E1530 – 11 (Reapproved 2016)**

Standard Test Method for Evaluating the Resistance to Thermal Transmission of Materials by the Guarded Heat Flow Meter Technique¹

This standard is issued under the fixed designation E1530; the number immediately following the designation indicates the year of original adoption or, in the case of revision, the year of last revision. A number in parentheses indicates the year of last reapproval. A superscript epsilon (ϵ) indicates an editorial change since the last revision or reapproval.

1. Scope

1.1 This test method covers a steady-state technique for the determination of the resistance to thermal transmission (thermal resistance) of materials of thicknesses less than 25 mm. For homogeneous opaque solid specimens of a representative thickness, thermal conductivity can be determined (see [Note 1](#)). This test method is useful for specimens having a thermal resistance in the range from 10 to $400 \times 10^{-4} \text{ m}^2 \cdot \text{K} \cdot \text{W}^{-1}$, which can be obtained from materials of thermal conductivity in the approximate range from 0.1 to $30 \text{ W} \cdot \text{m}^{-1} \cdot \text{K}^{-1}$ over the approximate temperature range from 150 to 600 K. It can be used outside these ranges with reduced accuracy for thicker specimens and for thermal conductivity values up to $60 \text{ W} \cdot \text{m}^{-1} \cdot \text{K}^{-1}$.

NOTE 1—A body is considered homogeneous when the property to be measured is found to be independent of specimen dimensions.

1.2 This test method is similar in concept to Test Method [C518](#), but is modified to accommodate smaller test specimens, having a higher thermal conductance. In addition, significant attention has been paid to ensure that the thermal resistance of contacting surfaces is minimized and reproducible.

1.3 The values stated in SI units are to be regarded as standard. The additional values are mathematical conversions to inch-pound units that are provided for information only and are not considered standard.

1.4 *This standard does not purport to address all of the safety concerns, if any, associated with its use. It is the responsibility of the user of this standard to establish appropriate safety and health practices and determine the applicability of regulatory limitations prior to use.*

2. Related Documents

2.1 *ASTM Standards:*²

[C518 Test Method for Steady-State Thermal Transmission Properties by Means of the Heat Flow Meter Apparatus](#)

[C1045 Practice for Calculating Thermal Transmission Properties Under Steady-State Conditions](#)

[E220 Test Method for Calibration of Thermocouples By Comparison Techniques](#)

[E1142 Terminology Relating to Thermophysical Properties](#)

[E1225 Test Method for Thermal Conductivity of Solids Using the Guarded-Comparative-Longitudinal Heat Flow Technique](#)

[F104 Classification System for Nonmetallic Gasket Materials](#)

[F433 Practice for Evaluating Thermal Conductivity of Gasket Materials](#)

3. Terminology

3.1 *Definitions of Terms Specific to This Standard:*

3.1.1 *heat flux transducer (HFT)*—a device that produces an electrical output that is a function of the heat flux, in a predefined and reproducible manner.

3.1.2 *thermal conductance (C)*—the time rate of heat flux through a unit area of a body induced by unit temperature difference between the body surfaces.

3.1.2.1 *average temperature of a surface*—the area-weighted mean temperature of that surface.

3.1.2.2 *average (mean) temperature of a specimen (disc shaped)*—the mean value of the upper and lower face temperatures.

¹ This test method is under the jurisdiction of ASTM Committee [E37](#) on Thermal Measurements and is the direct responsibility of Subcommittee [E37.05](#) on Thermophysical Properties.

Current edition approved Aug. 15, 2011; Sept. 1, 2016. Published September 2011; September 2016. Originally approved in 1993. Last previous edition approved in 2006; 2011 as ~~E1530 – 06~~ **E1530 – 11**. DOI: ~~10.1520/E1530-11~~ **10.1520/E1530-11R16**.

² For referenced ASTM standards, visit the ASTM website, www.astm.org, or contact ASTM Customer service at service@astm.org. For *Annual Book of ASTM Standards* volume information, refer to the standard's Document Summary page on the ASTM website.

3.1.3 *thermal conductivity* (λ)—(of a solid material)—the time rate of heat flow, under steady conditions, through unit area, per unit temperature gradient in the direction perpendicular to the area:

3.1.3.1 *apparent thermal conductivity*—when other modes of heat transfer through a material are present in addition to conduction, the results of the measurements performed in accordance with this test method will represent the apparent or effective thermal conductivity for the material tested.

3.1.4 *thermal resistance* (R)—the reciprocal of thermal conductance.

iTeh Standards
(<https://standards.iteh.ai>)
Document Preview

[ASTM E1530-11\(2016\)](#)

<https://standards.iteh.ai/catalog/standards/sist/94587ad0-11e2-4308-a4c3-8e004bcb7e1d/astm-e1530-112016>



3.2 Symbols:

3.2.1 λ —thermal conductivity, $\text{W}\cdot\text{m}^{-1}\cdot\text{K}^{-1}$
or $\text{Btu}\cdot\text{in.}\cdot\text{h}^{-1}\cdot\text{ft}^{-2}\cdot\text{°F}^{-1}$.

λ = thermal conductivity, $\text{W}\cdot\text{m}^{-1}\cdot\text{K}^{-1}$
or $\text{Btu}\cdot\text{in.}\cdot\text{h}^{-1}\cdot\text{ft}^{-2}\cdot\text{°F}^{-1}$

C = thermal conductance, $\text{W}\cdot\text{m}^{-2}\cdot\text{K}^{-1}$ or $\text{Btu}\cdot\text{h}^{-1}\cdot\text{ft}^{-2}\cdot\text{°F}^{-1}$

R = thermal resistance, $\text{m}^2\cdot\text{K}\cdot\text{W}^{-1}$ or $\text{h}\cdot\text{ft}^2\cdot\text{°F}\cdot\text{Btu}^{-1}$

Δx = specimen thickness, mm or in

A = specimen cross-sectional area, m^2 or ft^2

Q = heat flow, W or $\text{Btu}\cdot\text{h}^{-1}$

ϕ = heat flux transducer output, mV

N = heat flux transducer calibration constant, $\text{W}\cdot\text{m}^{-2}\cdot\text{mV}^{-1}$ or $\text{Btu}\cdot\text{h}^{-1}\cdot\text{ft}^{-2}\cdot\text{mV}^{-1}$

$N\phi$ = heat flux, $\text{W}\cdot\text{m}^{-2}$ or $\text{Btu}\cdot\text{h}^{-1}\cdot\text{ft}^{-2}$

ΔT = temperature difference, $^{\circ}\text{C}$ or $^{\circ}\text{F}$

T_g = temperature of guard heater, $^{\circ}\text{C}$ or $^{\circ}\text{F}$

T_u = temperature of upper heater, $^{\circ}\text{C}$ or $^{\circ}\text{F}$

T_l = temperature of lower heater, $^{\circ}\text{C}$ or $^{\circ}\text{F}$

T_1 = temperature of one surface of the specimen, $^{\circ}\text{C}$ or $^{\circ}\text{F}$

T_2 = temperature of the other surface of the specimen, $^{\circ}\text{C}$ or $^{\circ}\text{F}$

T_m = mean temperature of the specimen, $^{\circ}\text{C}$ or $^{\circ}\text{F}$

s = unknown specimen

r = known calibration or reference specimen

a = contacts

3.2.2 C —thermal conductance, $\text{W}\cdot\text{m}^{-2}\cdot\text{K}^{-1}$
or $\text{Btu}\cdot\text{h}^{-1}\cdot\text{ft}^{-2}\cdot\text{°F}^{-1}$.

3.2.3 R —thermal resistance, $\text{m}^2\cdot\text{K}\cdot\text{W}^{-1}$ or $\text{h}\cdot\text{ft}^2\cdot\text{°F}\cdot\text{Btu}^{-1}$.

3.2.4 Δx —specimen thickness, mm or in.

3.2.5 A —specimen cross-sectional area, m^2 or ft^2 .

3.2.6 Q —heat flow, W or $\text{Btu}\cdot\text{h}^{-1}$.

3.2.7 ϕ —heat flux transducer output, mV.

3.2.8 N —heat flux transducer calibration constant,
 $\text{W}\cdot\text{m}^{-2}\cdot\text{mV}^{-1}$ or $\text{Btu}\cdot\text{h}^{-1}\cdot\text{ft}^{-2}\cdot\text{mV}^{-1}$.

3.2.9 $N\phi$ —heat flux, $\text{W}\cdot\text{m}^{-2}$ or $\text{Btu}\cdot\text{h}^{-1}\cdot\text{ft}^{-2}$.

3.2.10 ΔT —temperature difference, $^{\circ}\text{C}$ or $^{\circ}\text{F}$.

3.2.11 T_g —temperature of guard heater, $^{\circ}\text{C}$ or $^{\circ}\text{F}$.

3.2.12 T_u —temperature of upper heater, $^{\circ}\text{C}$ or $^{\circ}\text{F}$.

3.2.13 T_l —temperature of lower heater, $^{\circ}\text{C}$ or $^{\circ}\text{F}$.

3.2.14 T_1 —temperature of one surface of the specimen, $^{\circ}\text{C}$ or $^{\circ}\text{F}$.

3.2.15 T_2 —temperature of the other surface of the specimen, $^{\circ}\text{C}$ or $^{\circ}\text{F}$.

3.2.16 T_m —mean temperature of the specimen, $^{\circ}\text{C}$ or $^{\circ}\text{F}$.

3.2.17 s —unknown specimen.

3.2.18 r —known calibration or reference specimen.

3.2.19 a —contacts.

4. Summary of Test Method

4.1 A specimen and a heat flux transducer (HFT) are sandwiched between two flat plates controlled at different temperatures, to produce a heat flow through the test stack. A reproducible load is applied to the test stack by pneumatic or other means, to ensure that there is a reproducible contact resistance between the specimen and plate surfaces. A guard surrounds the test stack and is maintained at a uniform mean temperature of the two plates, in order to minimize lateral heat flow to and from the stack. At steady state, the difference in temperature between the surfaces contacting the specimen is measured with temperature sensors embedded in the surfaces, together with the electrical output of the HFT. This output (voltage) is proportional to the heat flow through the specimen, the HFT and the interfaces between the specimen and the apparatus. The proportionality is obtained through prior calibration of the system with specimens of known thermal resistance measured under the same conditions, such that contact resistance at the surfaces is made reproducible.

5. Significance and Use

5.1 This test method is designed to measure and compare thermal properties of materials under controlled conditions and their ability to maintain required thermal conductance levels.

6. Apparatus

6.1 A schematic rendering of a typical apparatus is shown in Fig. 1. The relative position of the HFT to the specimen is not important (it may be on the hot or cold side) as the test method is based on maintaining axial heat flow with minimal radial heat losses or gains. It is also up to the designer whether to choose heat flow upward or downward or horizontally, although downward heat flow in a vertical stack is the most common one.

6.2 Key Components of a Typical Device (The numbers 1 to 22 in parentheses refer to Fig. 1):

6.2.1 The compressive force for the stack is to be provided by either a regulated pneumatic or hydraulic cylinder (1), dead weights or a spring loaded mechanism. In either case, means must be provided to ensure that the loading can be varied and set to certain values reproducibly.

6.2.2 The loading force must be transmitted to the stack through a gimball joint (2) that allows up to 5° swivel in the plane perpendicular to the axis of the stack.

6.2.3 Suitable insulator plate (3) separates the gimball joint from the top plate (4).

6.2.4 The top plate (assumed to be the hot plate for the purposes of this description) is equipped with a heater (5) and control thermocouple (6) adjacent to the heater, to maintain a certain desired temperature. (Other means of producing and maintaining temperature may also be used as long as the requirements in 6.3 are met.) The construction of the top plate is such as to ensure uniform heat distribution across its face contacting the specimen (8). Attached to this face (or embedded in close proximity to it) in a fashion that does not interfere with the specimen/plate interface, is a temperature sensor (7) (typically a thermocouple, resistance thermometer, or a thermistor) that defines the temperature of the interface on the plate side.

6.2.5 The specimen (8) is in direct contact with the top plate on one side and an intermediate plate (9) on the other side.

6.2.6 The intermediate plate (9) is an optional item. Its purpose is to provide a highly conductive environment to the second temperature sensor (10), to obtain an average temperature of the surface. If the temperature sensor (10) is embedded into the face of the HFT, or other means are provided to define the temperature of the surface facing the specimen, the use of the intermediate plate is not mandatory.

6.2.7 The heat flux transducer (HFT) is a device that will generate an electrical signal in proportion to the heat flux across it. The level of output required (sensitivity) greatly depends on the rest of the instrumentation used to read it. The overall performance of the HFT and its readout instrumentation shall be such as to meet the requirements in Section 13.

6.2.8 The lower plate (12) is constructed similarly to the upper plate (4), except it is positioned as a mirror image.

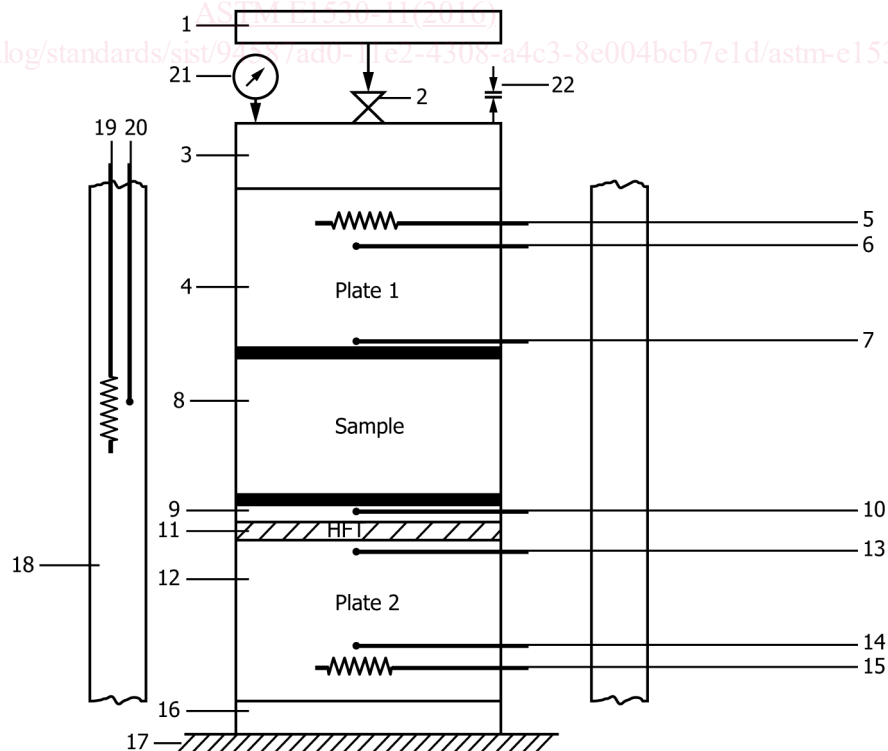

FIG. 1 Key Components of a Typical Device



6.2.9 An insulator plate (16) separates the lower plate (12) from the heat sink (17). In case of using circulating fluid in place of a heater/thermocouple arrangement in the upper or lower plates, or both, the heat sink may or may not be present.

6.2.10 The entire stack is surrounded by a guard whose cross section is not too much different from the stack's (18) equipped with a heater or cooling coils (19), or both, and a control thermocouple, resistance thermometer or thermistor (20) to maintain it at the mean temperature between the upper and lower plates. A small, generally unfilled, gap separates the guard from the stack. For instruments limited to operate in the ambient region, no guard is required but a draft shield is recommended in place of it.

NOTE 2—It is permissible to use thin layers of high-conductivity grease or elastomeric material on the two surfaces of the specimen to reduce the thermal resistance of the interface and promote uniform thermal contact across the interface area.

NOTE 3—The cross-sectional area and the shape of the specimen may be any, however, most commonly circular and rectangular cross sections are used. Minimum size is dictated by the magnitude of the disturbance caused by thermal sensors in relation to the overall flux distribution. The most common sizes are 25 mm round or square to 50 mm round.

6.2.11 The instrument is preferably equipped with suitable means (21) to measure the thickness of the specimen, in situ, in addition to provisions (22) to limit compression when testing elastomeric or other compressible materials.

NOTE 4—This requirement is also mandatory for testing materials that soften while heated.

6.3 Requirements:

6.3.1 Temperature control of upper and lower plate is to be $\pm 0.1^{\circ}\text{C}$ ($\pm 0.18^{\circ}\text{F}$) $\pm 0.1^{\circ}\text{C}$ ($\pm 0.18^{\circ}\text{F}$) or better.

6.3.2 Reproducible load of 0.28 MPa (40 psi) has been found to be satisfactory for solid specimens. Minimum load shall not be below 0.07 MPa (10 psi).

6.3.3 Temperature sensors are usually fine gage or small-diameter sheath thermocouples, however, ultraminiature resistance thermometers and linear thermistors may also be used.

6.3.4 Operating range of a device using a mean temperature guard shall be limited to from -100 to 300°C , 300°C , when using thermocouples as temperature sensors, and from -180 to 300°C , 300°C when platinum resistance thermometers are used. Thermistors are normally present on more restricted allowable temperature range of use.

7. Sampling and Conditioning

7.1 Cut representative test specimens from larger pieces of the sample material or body.

7.2 Condition the cut specimens in accordance with the requirements of the appropriate material specifications, if any.

8. Test Specimen

8.1 The specimen to be tested should be representative for the sample material. The recommended specimen configuration is a 50.8 ± 0.25 mm (2 ± 0.010 in.) diameter disk, having smooth flat and parallel faces, ± 0.025 mm (± 0.001 in.), such that a uniform thickness within ± 0.025 mm (± 0.001 in.) is attained in the range from 0.5 to 25.4 mm (0.020 to 1.0 in.) For testing specimens with thicknesses below 0.5 mm, a special technique, described in Annex A1, has to be used. Other frequently favored sizes are 25.4 mm (1.00 in.) round or square cross section.

9. Calibration

9.1 Select the mean temperature and load conditions required. Adjust the upper heater temperature (T_u) and lower heater temperature (T_l) such that the temperature difference at the required mean temperature is no less than 30 to 35°C , 35°C and the specimen ΔT is not less than 3°C , 3°C . Adjust the guard heater temperature (T_g) such that it is at approximately the average of T_u and T_l .

9.2 Select at least three calibration specimens having thermal resistance values that bracket the range expected for the test specimens at the temperature conditions required.

9.3 Table 1 contains a list of several available materials commonly used for calibration together with corresponding thermal resistance (R_s) values for a given thickness. This information is provided to assist the user in selecting optimum specimen thickness for testing a material and in deciding which calibration specimens to use.

9.4 The range of thermal conductivity for which this test method is most suitable is such that the optimum thermal resistance range is from 10×10^{-4} to 400×10^{-4} $\text{m}^2 \cdot \text{K} \cdot \text{W}^{-1}$. The most commonly used calibration materials are the Pyrex 7740 and Pyroceram 9606,³ Vespel⁴ (polyimide) and stainless steel all having well-established thermal conductivity behaviors with temperature.

9.5 Table 2 and Table 3 are listing thermal conductivity values for selected reference materials, with the appropriate bibliographic references appearing in bold characters. The temperature range listed for each reference material corresponds to the temperature range mentioned in each particular cited work, and in some cases exceeds the applicable temperature range for this

³ Pyrex 7740 and Pyroceram 9606 are products and trademarks of Corning Glass Co.

⁴ Vespel is a product and trademark of DuPont, Wilmington, DE.

**TABLE 1 Typical Thermal Resistance Values of Specimens of Different Materials**

Material	Approximate Thermal Conductivity, $W \cdot m^{-1} \cdot K^{-1}$ at 30°C	Thickness, mm	Approximate Thermal Resistance, $10^{-4} m^2 \cdot K \cdot W^{-1}$ at 30°C
Vespel ^A Polyimide	0.4	20	500
Vespel ^A Polyimide	0.4	10	250
Vespel ^A Polyimide	0.4	1	25
Polyethylene	0.2	1	50
Polyethylene	0.2	0.5	25
Polyethylene	0.2	0.1	5
Pyroceram 9606 ^B	4	20	50
Pyroceram 9606 ^B	4	10	25
Pyrex 7740 ^B Glass	1	20	200
Pyrex 7740 ^B Glass	1	10	100
Pyrex 7740 ^B Glass	1	1	10
304 Stainless Steel	14	20	14
304 Stainless Steel	14	10	7

^A Vespel is a product and trademark of DuPont, Wilmington, DE.

^B Pyrex 7740 and Pyroceram 9606 are products and trademarks of Corning Glass Co.

TABLE 2 Thermal Conductivity Values of Selected Reference Materials

Temperature (°C)	Thermal Conductivity ($W \cdot m^{-1} \cdot K^{-1}$)		
	Vespel ^A	Pyrex 7740 ^B	Pyroceram 9696 ^C
-50	...	1.010	...
0	...	1.104	...
25	0.377	1.177	4.03
100	0.391	1.236	3.65
200	0.413	1.330	3.40
300	0.436	1.447 ^D	3.24
400	3.14
500	3.05
600	2.98
700	2.91
800	2.84
900	2.77
1000	2.71

^A Jacobs-Fedore, R.A., and Stroe, D.E., *Thermophysical Properties of Vespel™ SP1*, in Thermal Conductivity 27 / Thermal Expansion 15, DEStech Publications, Inc., 2004, pp. 231–238.

^B Tye, R.P., and Salmon, D.R., *Thermal Conductivity Certified Reference Materials: Pyrex 7740 and Polymethylmethacrylate*, National Physical Laboratory report, 2004, Teddington, United Kingdom.

^C Stroe, D.E., Thermitus, M.A., and Jacobs-Fedore, R.A., *Thermophysical Properties of Pyroceram™ 9606*, in Thermal Conductivity 27 / Thermal Expansion 15, DEStech Publications, Inc., 2004, pp. 382–390.

^D Powell, R.W., Ho, C.Y., and Liley, P.E., *Thermal Conductivity of Selected Materials*, Special Publication NSRDS-NBS8, National Bureau of Standards, Washington DC.

test method. The information was, however, considered useful for the general user, and for that reason it was listed for the entire temperature range applicable to each reference material.

10. Procedure

10.1 Measure the thickness of the calibration specimen to 25 μm using a suitable caliper or gauge stand.

10.2 Coat both surfaces of a calibration specimen with a very thin layer of a compatible heat transfer compound or place a thin layer of elastomeric heat-transfer medium on it to help minimize the thermal resistance at the interfaces of adjacent contacting surfaces.

10.3 Release the compressive load on the specimen stack, open the test chamber, and insert the calibration specimen. Care must be taken to ensure that all surfaces are free of any foreign matter.

10.4 Close the test chamber and clamp the calibration specimen in position between the plates at the recommended compressive load of 0.28 MPa.