



**Designation: F606/F606M – 14a F606/F606M – 16**

# Standard Test Methods for Determining the Mechanical Properties of Externally and Internally Threaded Fasteners, Washers, Direct Tension Indicators, and Rivets<sup>1</sup>

This standard is issued under the fixed designation F606/F606M; the number immediately following the designation indicates the year of original adoption or, in the case of revision, the year of last revision. A number in parentheses indicates the year of last reapproval. A superscript epsilon ( $\epsilon$ ) indicates an editorial change since the last revision or reapproval.

*This standard has been approved for use by agencies of the U.S. Department of Defense.*

## 1. Scope\*

1.1 These test methods cover establishment of procedures for conducting tests to determine the mechanical properties of externally and internally threaded fasteners, washers, direct tension indicators, and rivets.

1.2 Property requirements and the applicable tests for their determination are specified in individual product standards. In those instances where the testing requirements are unique or at variance with these standard procedures, the product standard shall specify the controlling testing requirements. In the absence of any specified test requirement(s), these test methods shall apply.

1.3 These test methods describe mechanical tests for determining the following properties:

	Section
For Externally Threaded Fasteners:	3
Product Hardness	3.1
Proof Load	3.2.1
Method 1, Length Measurement	3.2.3
Method 2, Yield Strength	3.2.4
Method 3, Uniform Hardness	3.2.5
Axial Tension Testing of Full-Size Product	3.4
Wedge Tension Testing of Full-Size Product	3.5
Tension Testing of Machined Test Specimens	3.6
Total Extension at Fracture Test	3.7
Single Shear Test	3.8
For Internally Threaded Fasteners:	4
Product Hardness	4.1
Proof Load Test	4.2
Cone Proof Load Test	4.3
For Washers and Direct Tension Indicators:	5
Product Hardness-General Requirements	5.1
Through Hardened Washers	5.2
Carburized Washers	5.3
Stainless Steel and Nonferrous Washers	5.4
Direct Tension Indicators	5.5
Compression Load	5.6
For Rivets:	6
Product Hardness	6.1
Test for Embrittlement of Metallic-Coated Externally Threaded Fasteners	7
Test Method for Determining Decarburization and Carburization	8

1.4 The values stated in either SI units or inch-pound units are to be regarded separately as standard. The values stated in each system may not be exact equivalents; therefore, each system shall be used independently of the other. Combining values from the two systems may result in non-conformance with the standard.

NOTE 1—The values are stated in inch-pound for inch fasteners and SI metric units for metric fasteners.

1.5 *This standard does not purport to address all of the safety concerns, if any, associated with its use. It is the responsibility of the user of this standard to establish appropriate safety and health practices and determine the applicability of regulatory limitations prior to use.*

<sup>1</sup> These test methods are under the jurisdiction of ASTM Committee F16 on Fasteners and are the direct responsibility of Subcommittee F16.01 on Test Methods. Current edition approved Nov. 1, 2014. Published April 1, 2016. Originally approved in 1979. Last previous edition approved in 2014 as F606 – 14, F606 – 14a<sup>1</sup>. DOI: 10.1520/F0606\_F0606M-14A-10.1520/F0606\_F0606M-16.

\*A Summary of Changes section appears at the end of this standard

## 2. Referenced Documents

### 2.1 ASTM Standards:<sup>2</sup>

- A394 Specification for Steel Transmission Tower Bolts, Zinc-Coated and Bare
- E4 Practices for Force Verification of Testing Machines
- E8/E8M Test Methods for Tension Testing of Metallic Materials
- E10 Test Method for Brinell Hardness of Metallic Materials
- E18 Test Methods for Rockwell Hardness of Metallic Materials
- E83 Practice for Verification and Classification of Extensometer Systems
- E92 Test Methods for Vickers Hardness and Knoop Hardness of Metallic Materials
- E384 Test Method for Microindentation Hardness of Materials
- F436/F436M Specification for Hardened Steel Washers Inch and Metric Dimensions
- F959 Specification for Compressible-Washer-Type Direct Tension Indicators for Use with Structural Fasteners
- F1624 Test Method for Measurement of Hydrogen Embrittlement Threshold in Steel by the Incremental Step Loading Technique
- F2328 Test Method for Determining Decarburization and Carburization in Hardened and Tempered Threaded Steel Bolts, Screws, Studs, and Nuts
- F2328M Test Method for Determining Decarburization and Carburization in Hardened and Tempered Threaded Steel Bolts, Screws, Studs, and Nuts (Metric)

### 2.2 Military Standard:<sup>3</sup>

- MIL STD 1312, Test 13 and Test 20

## 3. Test Methods for Externally Threaded Fasteners

3.1 *Product Hardness*—Tests shall be conducted after the removal of any surface oxide, decarburization, plating or other coating. All readings shall be within the hardness values listed in the product specification. The average of all readings on the same part shall be considered as the product hardness. Test results shall conform to the product specification for the lot represented by the test specimens to be considered conforming. Test specimen preparation and hardness tests shall be conducted in accordance with Test Methods E18 for Rockwell tests, Test Method E10 for Brinell tests, Test Method E92 for Vickers tests, or Test Method E384 for Microhardness tests. The method used is at the option of the manufacturer, with regards to the size and grade of the products.

3.1.1 *Routine Test Locations*—For testing the hardness of the finished product, the following test locations can be used:

3.1.1.1 For hex and square head bolts; test shall be conducted on the wrench flats, top of head, unthreaded shank, end of bolt or at the arbitration location.

3.1.1.2 For studs, products without parallel wrench flats and for head styles other than hex and square; tests shall be conducted on the unthreaded shank, end of the bolt or stud or at the arbitration location.

3.1.1.3 Stress relieved products (3.1.1.1 and 3.1.1.2) are measured anywhere on the surface or through the cross section. Refer to the product specification for particular test location or use the arbitration location.

3.1.1.4 The Rockwell Hardness Scale may be used for all product diameters; however, the Brinell hardness is limited to products over 1½-in. or M36.

3.1.2 *Laboratory Inspection*—A minimum of three readings shall be taken on each sample of finished product.

3.1.3 *Arbitration Test Location*—For purposes of arbitration between the purchaser and seller over reported test results, hardness tests shall be conducted at the mid-radius ( $r/2$ ) of a transverse section through the threads taken at a distance of approximately one diameter from the point end of the bolt or one end of the stud. Four readings shall be taken from the point end of the bolt or one end of the stud. Four readings shall be taken approximately 90° to one another on the same plane, if product size permits. Smaller diameter products may also use the opposite parallel surface area of the bolt head end as sectioned above (see Fig. 1). The use of Brinell hardness for arbitration testing is limited to product sizes greater than 2¼-in. or M60.

3.2 *Tension Tests*—It is preferred that bolts and studs be tested full size, and it is customary, when so testing, to specify a minimum ultimate load (or stress) in pounds-force (or pounds-force per square inch.) for inch fasteners and or load in newtons-force or megapascals MPa for metric fasteners. Sections 3.2 – 3.5 apply when testing externally threaded fasteners full size. Section 3.6 shall apply where the individual product specifications permit the use of machined specimens (see Test Methods E8/E8M).

3.2.1 *Proof Load*—The proof-load test consists of stressing the product with a specified load that the product must withstand without measurable permanent set. Alternative tests for determining the ability of a fastener to pass the proof-load test are the yield strength test and the uniform hardness test. Either Method 1 (3.2.3), Method 2 (3.2.4), or Method 3 (3.2.5) may be used, but Method 1 shall be the arbitration method in case of any dispute as to acceptance of the product (see Test Methods E8/E8M).

<sup>2</sup> For referenced ASTM standards, visit the ASTM website, [www.astm.org](http://www.astm.org), or contact ASTM Customer Service at [service@astm.org](mailto:service@astm.org). For *Annual Book of ASTM Standards* volume information, refer to the standard's Document Summary page on the ASTM website.

<sup>3</sup> DLA Document Services Building 4/D 700 Robbins Avenue Philadelphia, PA 19111-5094 <http://quicksearch.dla.mil/>

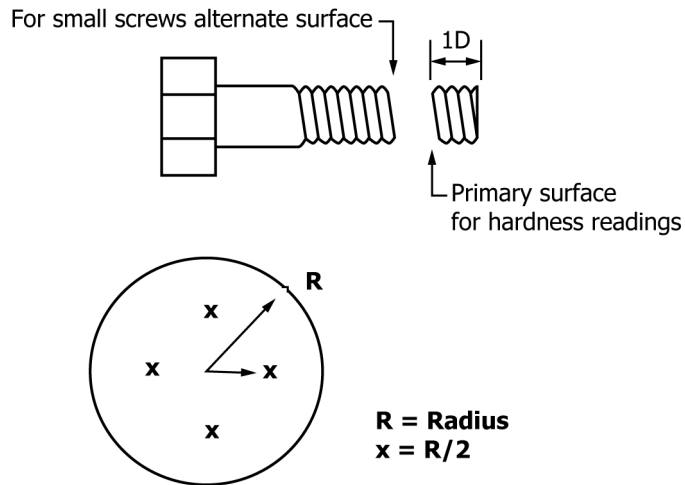

FIG. 1 Hardness Arbitration Test Location

3.2.2 In both Methods 1 and 2, assemble the product in the fixture of the tension testing machine so that six complete threads (except for heavy hex structural bolts, which shall be based on four threads) are exposed between the grips. This is obtained by freely running the nut or fixture to the thread runout of the specimen and then unscrewing the specimen six full turns. For continuous thread bolts, at least six full threads shall be exposed between the fixture ends; however, for referee purposes, six full threads shall be exposed.

3.2.3 *Method 1, Length Measurement*—To ensure consistent and repetitive length measurements of the fastener, the threaded end and top of the bolt head shall have conical depressions made at the approximate axis or center line of the fastener. In the event of a dispute over test results the test shall be conducted after the removal of all manufacturer or grade markings, surface oxide, decarburization, plating, other coating, or a combination thereof, to achieve a clean, flat surface and the conical depressions shall be created using a lathe or some type of centering fixture. All debris shall be removed from the conical depressions before measuring the part. When fasteners are too long to test in the available equipment the fastener may be cut to 8 inches  $\pm$  0.125 for inch fasteners or a length of 200 mm  $\pm$  3.0 mm for metric fasteners and tested using Method 1. If there is a dispute over results when testing the same part or lot of parts, both full size and cut fastener the cut fastener results shall be used to determine acceptance. The measuring instrument shall have pointed anvils which mate with the center line depressions and be capable of measuring changes in length of 0.0001 in. for inch fasteners and 0.0025 mm for metric fasteners. The instrument accuracy shall be within 0.0001 in. in any 0.001 in. range for inch parts and within 0.0025 mm accuracy within any 0.025 mm range for metric parts. Place the fastener between the measuring anvils. The fastener shall be rotated at least 360 degrees to assure sound seating. At the position where the lowest value is indicated the instrument shall be zeroed or the indicated measurement shall be recorded. If using a bolt extensometer, the bolt with attached extensometer may be assembled into the tension testing machine. If not, mark the fastener so it may be placed as close as possible to the same position for the second reading. Remove and assemble the fastener into the tension testing machine as outlined in 3.4. With a test speed which shall not exceed 0.12 in./min for inch fasteners and 3.0 mm/min for metric fasteners, as determined with a free-running cross head, axially load the fastener to the proof load value specified in the product specification. This load shall be maintained for a period of 10 s before releasing the load. Replace the fastener between the measuring anvils and rotate at least 360 degrees as before. The fastener shall be stopped at the position where the lowest value is indicated. The measurement shall show no permanent elongation. A tolerance of  $\pm$ 0.0005 in. for inch fasteners and  $\pm$  0.013 mm for metric fasteners shall be allowed (for measurement error only) between the measurement made before loading and that made after loading. Variables such as straightness, thread alignment, or measurement error could result in apparent elongation of the product when the specified proof load is initially applied. In such cases, the product may be retested using a 3 % greater load, and shall be considered acceptable if there is no difference in the length measurement after this loading within a 0.0005 in. for inch fasteners and  $\pm$  0.013 mm for metric fasteners, measurement tolerance as outlined.

3.2.4 *Method 2, Yield Strength*—Assemble the product in the testing equipment as outlined in 3.4. As the load is applied, measure and record the total elongation of the product or any part of it that includes the exposed threads to produce a load-elongation diagram. Determine the load or stress at an offset equal to 0.2 % of the length of bolt occupied by six full threads as shown in Fig. 2 (except for heavy hex structural bolts, which shall be based on four threads) by the method described in 3.6.3.1.

3.2.4.1 *Method 2A, Yield Strength for Austenitic Stainless Steel and Non-ferrous Materials*—Assemble the product in the testing equipment as outlined in 3.4. As the load is applied, measure and record the total elongation of the product in order to produce a load elongation diagram. Determine the load or stress at an offset equal to 0.2 % strain based on the length of the bolt between the holders as shown in Fig. 2, which will be subject to elongation under load by using the method described in 3.6.3.1.

3.2.5 *Method 3, Uniform Hardness*—The fasteners shall be tested for hardness as described in 3.1, and in addition, the hardness shall also be determined in the core. The difference between the mid-radius and core hardness shall be not more than 3 points on

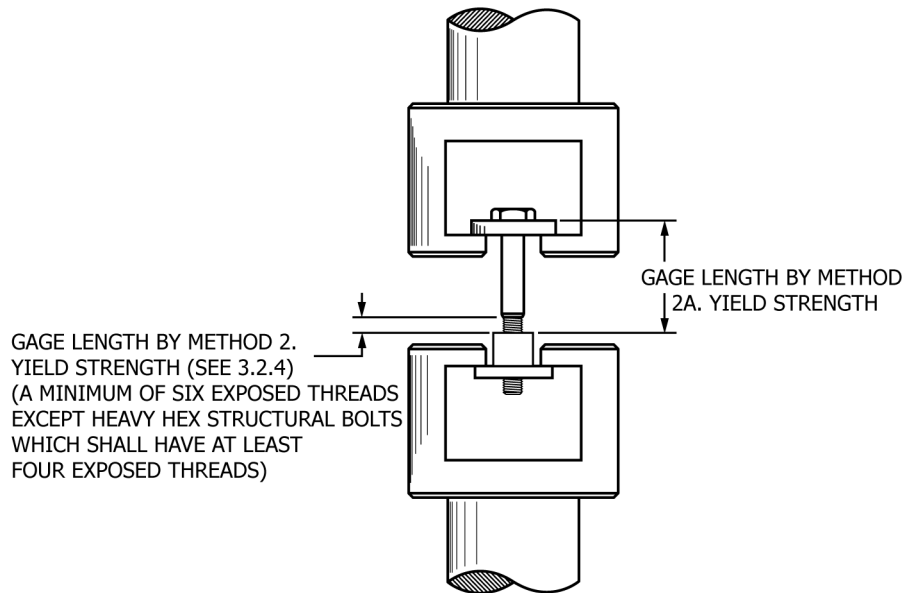

FIG. 2 Tension Testing of Full-Size Bolt (Typical Set-Up)

a Rockwell C Scale; and both readings must be within product specification. This test is valid for fasteners up to and including 1 in. for inch fasteners and M24 diameter for metric fasteners.

3.3 *Bolts or Studs Too Short for Tension Testing*—Product lengths less than those shown in Table 1 for product ¼ through ¾ in. for inch fasteners and M5 through M20 for metric fasteners in diameter and less than three diameters in length for product above ¾ in. and M20 in diameter, or that do not have sufficient threads for proper engagement and still leave the specified number of complete threads exposed between the grips, shall be deemed too short for tension testing, and acceptance shall be based on a hardness test performed in accordance with 3.1. If tests other than product hardness are required, their requirements should be referenced in the product specification. When differences in tensile testing lengths exist between this standard and product standards, the requirements of the product standard shall take precedence. Minimum length in Table 1 indicates the nominal specified length of an inch fastener (that is an A449 Hex Cap Screw size is specified as ½-13 × 1 ⅝ indicates 1 ⅝ in. is the nominal length) and Table 2 for a metric fastener for size M12 ×30 indicates the nominal length is 30 mm.

3.4 *Axial Tension Testing of Full-Size Products:*

3.4.1 Bolts may be tested in a holder with the load axially applied between the head and a nut or suitable fixture (Fig. 2), either of which shall have sufficient thread engagement to develop the full strength of the product. Assemble the nut or fixture on the product, leaving a minimum of six complete bolt threads exposed between the grips except for heavy hex structural bolts, which shall have four complete threads exposed between the grips.

3.4.2 Studs may be tested by assembling one end in the threaded fixture to the thread runout. For studs having unlike threads, this shall be the end with the finer pitch thread, or with the larger minor diameter. Likewise, assemble the other end of the stud in a threaded fixture, leaving six complete threads exposed between the grips. For continuously threaded studs, at least six complete threads shall be exposed between the fixture ends. The maximum speed of the free-running cross head shall not exceed 1 in./min for inch fasteners and 25 mm/min for metric fasteners. When reporting the tensile strength of inch product, in pounds-force per square inch, calculate the thread stress area as follows:

$$A_s = 0.7854 [D - (0.9743)/n]^2 \tag{1}$$

TABLE 1 Minimum Length of Product Requiring Tension Testing

Nominal Product Size, in.	Minimum Nominal Length, in.
¼	⅝
⅝	¾
⅜	⅞
⅞	1
½	1 ⅝
⅞	1 ¼
⅝	1 ½
¾	1 ¾
⅞ and larger	3 dia

**TABLE 2 Minimum Length of Product Requiring Tension Testing**

Nominal Product Size, mm	Minimum Nominal Length, mm
M5	12
M6	14
M8	20
M10	25
M12	30
M14	35
M16	40
M20	45
Over M20	3 dia

where:

$A_s$  = thread stress area, in.<sup>2</sup>,

$D$  = nominal diameter of bolt or stud, in., and

$n$  = number of threads per inch.

When reporting the tensile strength of metric product, in megapascals MPa calculate the thread stress area as follows:

$$A_s = 0.7854 [D - (0.9382 P)]^2 \quad (2)$$

where:

$A_s$  = thread stress area, mm<sup>2</sup>,

$D$  = nominal diameter of bolt or stud, mm, and

$P$  = thread pitch, mm.

3.4.3 To meet the requirements of the test described in 3.4.1 and 3.4.2, the product shall support a load prior to fracture not less than the minimum tensile load specified in the product specification for its size, strength, and thread series. In addition, unless otherwise specified, the tensile fracture shall occur in the free threaded length. Fracture in the head or at the junction of the head and shank is prohibited at any load, including those above the minimum requirements.

3.4.3.1 For externally threaded fasteners, if the unthreaded shank diameter is reduced to be equal to or less than the basic thread pitch diameter, the fracture shall occur in the free threaded length or in the unthreaded shank.

3.4.3.2 For screws threaded to the head, fracture that causes failure may extend or spread into the transition section between the head and the thread, or into the head, before separation, provided that it originates in the free threaded length.

3.4.3.3 For fasteners made of non hardened steel (that is, not quench and tempered) or austenitic stainless steel, the fracture shall occur in the free threaded length or in the unthreaded shank.

3.4.3.4 For fasteners made of austenitic stainless steel, if the test fastener's thread pulls out of the internally threaded test fixture above the minimum specified tensile load, the fastener shall be considered conforming to the tensile strength requirement.

3.5 *Wedge Tension Testing of Full-Size Product*—The wedge tensile strength of a hex or square-head fastener, socket-head cap screw (with the exception of socket button or flat countersunk head products) or stud is the tensile load that the product is capable of sustaining when stressed with a wedge under the head. The purpose of this test is to obtain the tensile strength and demonstrate the “head quality” and ductility of the product.

3.5.1 *Wedge Tension Testing of Bolts*—Determine the ultimate load of the bolt as described in 3.4 except place a wedge under the bolt head. When both wedge tension and proof load testing are required by the product specification use the proof load tested bolts—the bolts that have been the proof load-tested in accordance with Method 1 (3.2.3) or Method 3 (3.2.5) may be used for wedge testing. Fasteners that have been yield strength tested utilizing either Method 2 (3.2.4) or Method 2A (3.2.4.1) shall not be reused for wedge testing. The wedge shall have a minimum hardness of 45 HRC. Additionally, the wedge shall have a minimum thickness of one half the nominal bolt diameter (measured at the thin side of the hole, see Fig. 3). The wedge shall have an included angle as shown in Table 3 and Table 4 for the product type being tested. The hole in the wedge shall have a clearance over the nominal size of the bolt, and its top and bottom edges shall be rounded as specified in Table 5 and Table 6. The minimum outside dimension of the wedge shall be such that during the test no corner loading of the product head (adjacent to the wedge) shall occur (see head orientation in Fig. 3). The bolt shall be tension tested to fracture. To meet the requirements of this test, the bolt shall support a load prior to fracture not less than the minimum tensile load specified in the product specification for its size, strength, and thread series. In addition, unless otherwise specified, the tensile fracture shall occur in the free thread length. Fracture in the head or at the junction of the head and shank is prohibited at any load, including those above the minimum requirements.

**NOTE 2**—Fasteners that have been manufactured/in-stock or on order prior to the approval of Test Methods F606/F606M–16 that utilized the same fastener for both yield strength and wedge tensile testing are acceptable and may be supplied/used as-is without additional testing until existing stock has been depleted. Fasteners that are placed on order and manufactured after the issuance of Test Methods F606/F606M–16 that are yield strength and wedge tensile tested shall follow the revised requirement in 3.5.1.

3.5.1.1 For externally threaded fasteners, if the unthreaded shank diameter is reduced to be equal to or less than the basic thread pitch diameter, the fracture shall occur in the free threaded length or in the unthreaded shank.

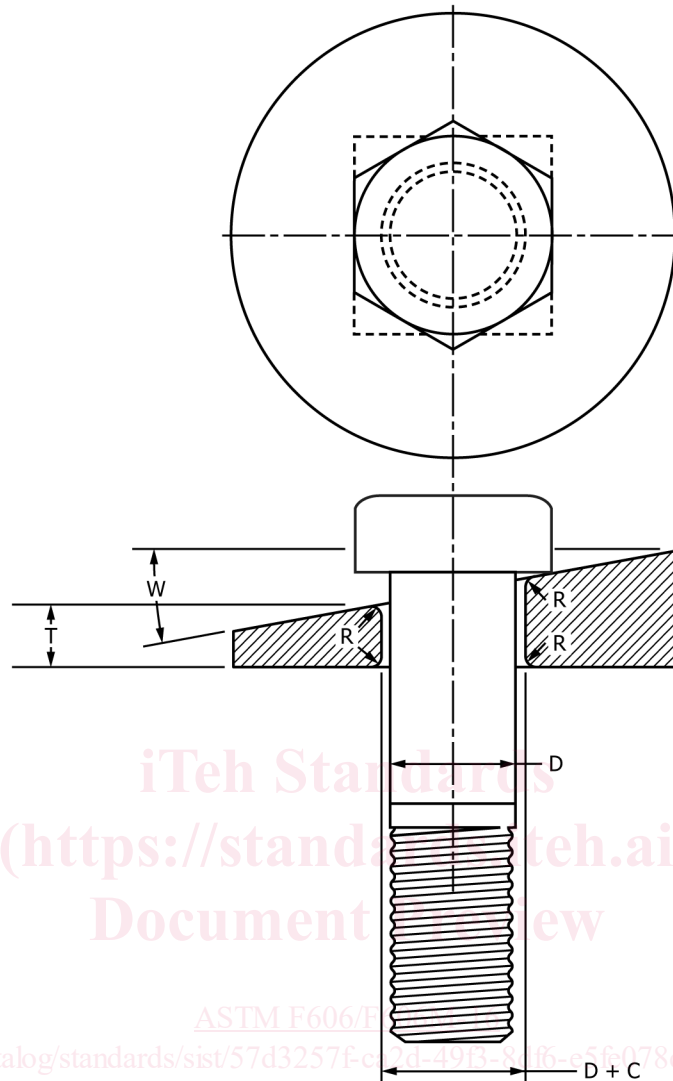

$c$  = clearance of hole  
 $D$  = diameter of bolt or screw  
 $R$  = radius or chamfer  
 $T$  = reference thickness of wedge at thin side of hole equals one half diameter of bolt or screw  
 $W$  = wedge angle (see Table 3)

FIG. 3 Wedge Test Details—Bolts

TABLE 3 Tension Test Wedge Angles for Inch Bolts and Screws

NOTE 1—For use with hardened and tempered steel and alloy steel standard products. For non-ferrous and special products, see the related product specification. Unless otherwise specified, Table 3 shall apply.

Nominal Product Size, in.	Degrees	
	Bolts <sup>A</sup>	Studs and Flange Bolts
1/4 – 1	10	6
Over 1	6	4

<sup>A</sup> Heat-treated bolts that are threaded one diameter or closer to the underside of the head, shall use a wedge angle of 6° for sizes 1/4 through 3/4 in. and 4° for sizes over 3/4 in.

3.5.1.2 For screws threaded to the head, fracture that causes failure may extend or spread into the transition section between the head and the thread, or into the head, before separation, provided that it originates in the free threaded length.

**TABLE 4 Tension Test Wedge Angles for Metric Bolts and Screws**

NOTE 1—For use with hardened and tempered steel and alloy steel standard products. For non-ferrous and special products, see the related product specification.

Nominal Product Size, mm.	Degrees	
	Bolts <sup>A</sup>	Studs and Flange Bolts
M5–M24	10	6
Over M24	6	4

<sup>A</sup> Heat-treated bolts that are threaded one diameter or closer to the underside of the head, shall use a wedge angle of 6° for sizes M5 through M20 and 4° for sizes over M20.

**TABLE 5 Tensile Test Wedge Hole Clearance—Details for Inch Bolts and Screws**

NOTE 1—Fracture at the junction of the head and shank is prohibited at any load, including those above the minimum requirements.

Nominal Product Size, in.	Nominal Clearance in Hole, in.	Nominal Radius on Corners of Hole, in.
1/4 – 1/2	0.030	0.030
9/16 – 3/4	0.050	0.060
7/8 – 1	0.060	0.060
1 1/8 – 1 1/4	0.060	0.125
1 3/8 – 1 1/2	0.094	0.125
1 3/4 – 2	0.094	0.225
2 1/4 – 3	0.125	0.256

**TABLE 6 Tensile Test Wedge Hole Clearance—Details for Metric Bolts and Screws**

NOTE 1—Fracture at the junction of the head and shank is prohibited at any load, including those above the minimum requirements.

Nominal Product Size, mm.	Nominal Clearance in Hole, mm	Nominal Radius on Corners of Hole, mm
M5 and M6	0.050	0.70
M5 and M6 Over M6–M12	0.50	0.70
Over M6–M12	0.080	0.80
Over M6–M12	0.80	0.80
Over M12–M20	1.60	1.30
Over M20–M36	3.20	1.60
Over M36	3.20	3.20

3.5.1.3 For fasteners made of non hardened steel (that is, not quench and tempered) or austenitic stainless steel, the fracture shall occur in the free threaded length or in the unthreaded shank.

3.5.1.4 For fasteners made of austenitic stainless steel, if the test fastener’s thread pulls out of the internally threaded test fixture above the minimum specified tensile load, the fastener shall be considered conforming to the wedge tensile strength requirement.

NOTE 3—Fracture at the junction of the head and shank is prohibited at any load, including those above the minimum requirements.

3.5.2 *Wedge Tension Testing of Studs*—When both wedge tension and proof load testing are required by the product specifications, assemble one end of the same stud previously used for proof load testing in a threaded fixture to the thread runout. For studs having unlike threads, this shall be the end with the finer pitch thread or with the larger minor diameter. Assemble the other end of the stud in a threaded wedge to the runout and then unscrew six full turns, thus leaving six complete threads exposed between the grips, as illustrated in Fig. 4. For continuous thread studs, at least six complete threads shall be exposed between the fixture ends. The angle of the wedge for the stud size and grade or property class shall be as specified in Table 3 and Table 4. Assemble the stud in the testing machine and tension test to fracture, as described in 3.4. The minimum hardness of the threaded wedge shall be 45 HRC. The length of the threaded section of the wedge shall be equal to at least the diameter of the stud. To facilitate removal of the broken stud, the threaded wedge may be counterbored on the faces as shown in Fig. 4. The thickness of the wedge at the thin side of the hole shall equal the diameter of the stud plus the depth of counterbore. The thread in the wedge shall have Class 3B tolerances for inch parts and a 5H tolerance for metric parts, except when testing studs having an interference fit thread, in which case the wedge shall be threaded to provide a finger-tight fit. The supporting fixture, as shown in Fig. 4, shall have a hole clearance over the nominal size of the stud, and shall have its top and bottom edges rounded or chamfered to the same

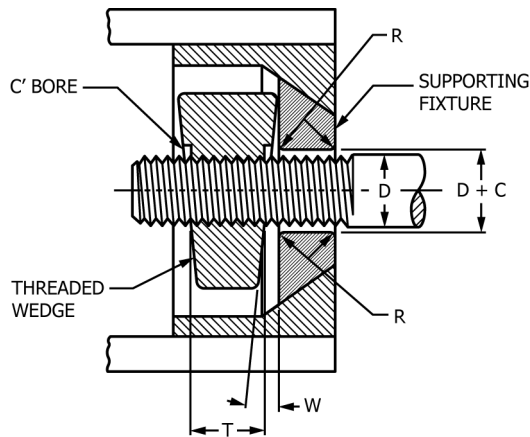

$C$  = clearance of hole,  
 $D$  = diameter of stud,  
 $R$  = radius or chamfer,  
 $T$  =  $E$  plus depth of counterbore,  
 $W$  = wedge angle,  
 $E$  = length of threaded section of wedge =  $D$

FIG. 4 Wedge Test Details—Studs

limits specified for the hardened wedge washers in Table 5 and Table 6. To meet the requirements of this test, the stud shall support a load prior to fracture not less than the minimum tensile strength specified in the product specification for its size, grade, and thread series. When tensile testing externally threaded fasteners made of austenitic stainless steel and the test fastener's thread pulls out of the internally threaded test fixture after the minimum tensile strength requirement has been reached, the fasteners shall be considered conforming to the tensile strength requirement.

NOTE 4—Dimensional tolerances for all test fixtures used in this test method, unless otherwise noted, shall conform to standard machining practices.

3.6 Tension Testing of Machined Test Specimens:

3.6.1 Where bolts and studs cannot be tested full size, conduct tests using test specimens machined from the bolt or stud (see Test Methods E8/E8M).

3.6.1.1 Bolts and studs  $\frac{1}{16}$  in. and smaller may be machined concentric with the axis of the bolt or stud for inch fasteners and M14 for metric fasteners. The specimen shall have a turned section as large as feasible and shall have a gage length four times the diameter of the specimen. See Fig. 5, Fig. 6.

3.6.1.2 Bolts and studs  $\frac{5}{8}$  in. in diameter through  $1\frac{1}{4}$  in. for inch fasteners and M16 through M30 for metric fasteners may have their shanks machined concentric with the axis of the bolt or stud, leaving the bolt head and threaded section intact as shown in Fig. 5 and Fig. 6, however heat treated bolts in these size ranges must not be reduced by more than 25% of their original diameter. Alternatively, bolts and studs  $\frac{5}{8}$  in. in diameter through  $1\frac{1}{4}$  in. for inch fasteners and M16 through M30 for metric fasteners may have their shanks machined to a test specimen with the axis of the specimen located midway between the axis and outside surface of the bolt or stud as shown in Fig. 7. Bolts of a small cross section that will not permit taking test specimens as shown in Fig.

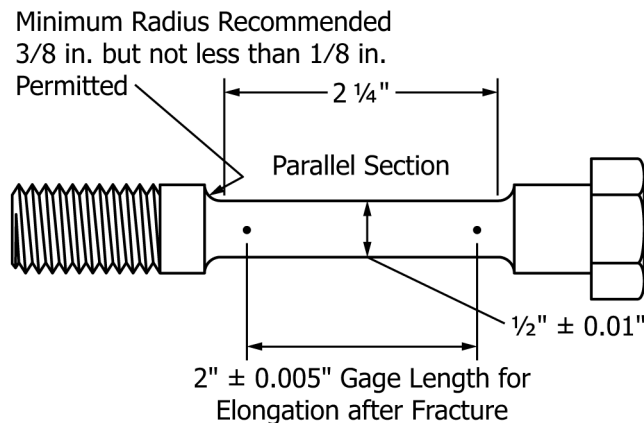
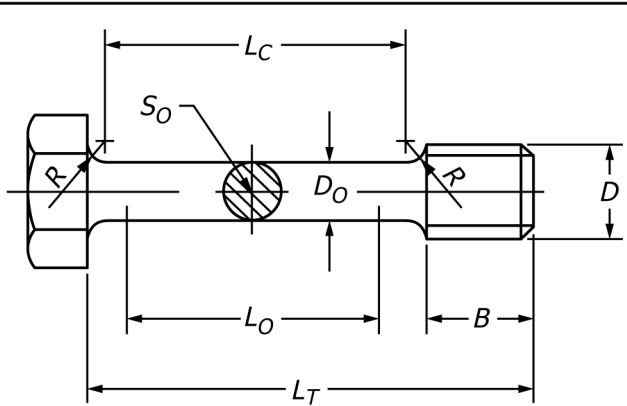

FIG. 5 Tension Test Specimen for Bolt with Turned-Down Shank for Inch Bolts





$D$  = nominal thread diameter,  
 $D_O$  = diameter of test piece ( $D_O < \text{minor diameter of thread}$ ),  
 $B$  = length of thread ( $B \geq D$ ),  
 $L_C = 5D_O$  or  $(5.65 \sqrt{S_O})$ ,  
 $L_O = 5D_O$  or  $(5.65 \sqrt{S_O})$ ,  
 $L_C$  = length of straight portion ( $L_O + D_O$ ),  
 $L_T$  = total length of test piece ( $L_C + 2R + B$ ),  
 $L_U$  = length after fracture,  
 $S_O$  = cross-sectional area, and  
 $R$  = fillet radius ( $R \geq 4\text{mm}$ )

FIG. 6 Tension Specimens with Turned-down Shank for Metric Bolts

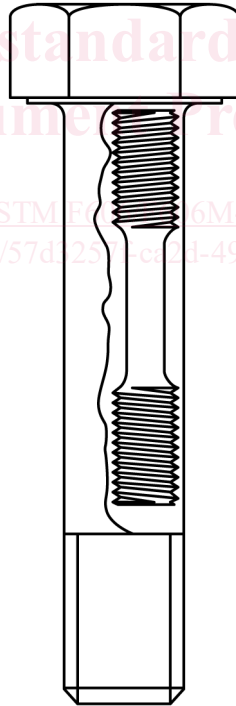

FIG. 7 Location of Standard Round 2-in. Gage Length Tension Test Specimen When Turned from Large Size Bolt

5 or Fig. 6 for inch and metric fasteners respectively, shall have a turned section as large as feasible and concentric with the axis of the bolt or stud. The gage length for measuring the elongation shall be four times the diameter of the specimen. Fig. 5 and Fig. 6 illustrate an example of these small-size specimens. For arbitration purposes, machined test specimens for bolts and studs  $\frac{5}{8}$  in. through  $1\frac{1}{4}$  in. for inch fasteners and M16 through M30 for metric fasteners shall be machined with the axis of the specimen located midway between the center and outside surface shown in Fig. 7.

3.6.1.3 Bolts and studs 1 3/8 in. or M33 and larger may have their shanks machined to test specimen with the axis of the specimen located midway between the center and outside surface of the bolt or stud as shown in Fig. 7 to sizes indicated in Fig. 5 and Fig. 6 for inch and metric fasteners respectively.

3.6.1.4 Machined test specimens shall exhibit tensile strength, yield strength (or yield point), elongation, and reduction of area equal to or greater than the values of these properties specified for the product size in the applicable product specification when tested in accordance with this section.

3.6.2 *Determination of Tensile Properties:*

3.6.2.1 *Yield Point*—Yield point is the first stress in a material, less than the maximum obtainable stress, at which an increase in strain occurs without an increase in stress. Yield point is intended for application only for materials that may exhibit the unique characteristic of showing an increase in strain without an increase in stress. The stress-strain diagram is characterized by a sharp knee or discontinuity. Determine yield point by one of the following methods:

3.6.2.2 *Drop of the Beam or Halt of the Pointer Method*—In this method apply an increasing load to the specimen at a uniform rate. When a lever and poise machine is used, keep the beam in balance by running out the poise at approximately a steady rate. When the yield point of the material is reached, the increase of the load will stop, but run the poise a trifle beyond the balance position, and the beam of the machine will drop for a brief but appreciable interval of time. When a machine equipped with a load-indicating dial is used, there is a halt or hesitation of the load-indicating pointer corresponding to the drop of the beam. Note the load at the “drop of the beam” or the “halt of the pointer” and record the corresponding stress as the yield point.

3.6.2.3 *Autographic Diagram Method*—When a sharp-kneed stress-strain diagram is obtained by an autographic recording device, take the stress corresponding to the top of the knee (Fig. 8), or the stress at which the curve drops as the yield point (Fig. 9).

3.6.2.4 *Total Extension Under Load Method*—When testing material for yield point and the test specimens may not exhibit a well-defined disproportionate deformation that characterizes a yield point as measured by the drop of the beam, halt of the pointer, or autographic diagram methods described in 3.6.2.2 and 3.6.2.3, a value equivalent to the yield point in its practical significance may be determined by the following method and may be recorded as yield point: Attach a Class C or better extensometer (Note 45 and Note 56) to the specimen. When the load producing a specified extension (Note 67) is reached, record the stress corresponding to the load as the yield point, and remove the extensometer (Fig. 10).

NOTE 5—Automatic devices are available that determine the load at the specified total extension without plotting a stress-strain curve. Such devices may be used if their accuracy has been demonstrated. Multiplying calipers and other such devices are acceptable for use provided their accuracy has been demonstrated as equivalent to a Class C extensometer.

NOTE 6—Reference should be made to Practice E83.

NOTE 7—For steel inch fasteners with a specified yield point not over 80 000 psi, an appropriate value is 0.005 in./in. of gage length. For values above

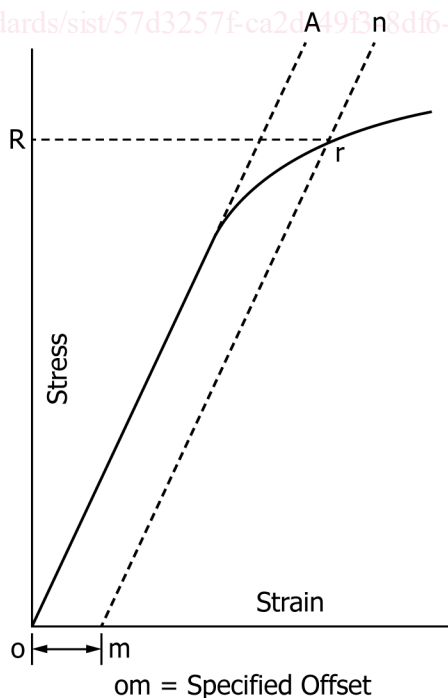

FIG. 8 Stress-Strain Diagram for Determination of Yield Strength by the Offset Method