



Designation: D409/D409M – 16

Standard Test Method for Grindability of Coal by the Hardgrove-Machine Method¹

This standard is issued under the fixed designation D409/D409M; the number immediately following the designation indicates the year of original adoption or, in the case of revision, the year of last revision. A number in parentheses indicates the year of last reapproval. A superscript epsilon (ϵ) indicates an editorial change since the last revision or reapproval.

This standard has been approved for use by agencies of the U.S. Department of Defense.

INTRODUCTION

This test method is structured into the following parts:

The body of the test method discusses the scope, referenced documents, significance and use, apparatus, gross samples, preparation of test samples, procedure, calculation and report, precision and bias, and keywords.

Annex A1 contains the method to obtain and prepare coal feedstock for potential use as HGI RMs (reference materials).

Annex A2 contains the method to divide and containerize the candidate HGI RMs (candidate HGI RMs) from the feedstock prepared in **Annex A1**.

Annex A3 contains the method for homogeneity testing of the candidate HGI RMs containerized in **Annex A2**.

Annex A4 contains the method for determining the Hardgrove grindability index (HGI) to be assigned to each lot of the candidate HGI RMs.

Annex A5 contains the method used to calibrate a Hardgrove grindability machine using the primary or secondary HGI RMs.

Annex A6 contains the method for determining the moisture content of the 1.18 × 0.60 mm (No. 16 × 30) test sample.

1. Scope

1.1 This test method² covers the determination of the relative grindability or ease of pulverization of coals in comparison with coals chosen as standards. A prepared and sized sample receives a definite amount of grinding energy in a miniature pulverizer, and the size consist of the pulverized product is determined by sieving. The resultant size consist is

used to produce an index relative to the ease of grinding [Hardgrove Grindability Index (HGI)].

1.1.1 Some coals, such as some high-volatile bituminous, subbituminous, and lignite coals, can undergo physical change as the natural or seam moisture is released during handling and preparation. This change is often sufficient to alter the grindability characteristics that will be reported when tested in the laboratory and could produce different indices dependent on the conditions of drying and the moisture level of the 1.18 × 0.60 mm (No. 16 × 30) (see Test Method **D4749**) materials used for the test. Therefore, the repeatability and reproducibility cited in this test method may not apply for these high-volatile bituminous, subbituminous, and lignite coals.

1.2 The values stated in either SI units or inch-pound units are to be regarded separately as standard. The values stated in each system may not be exact equivalents; therefore, each system shall be used independently of the other. Combining values from the two systems may result in non-conformance with the standard.

¹ This test method is under the jurisdiction of ASTM Committee **D05** on Coal and Coke and is the direct responsibility of **D05.07** on Physical Characteristics of Coal.

Current edition approved Sept. 1, 2016. Published September 2016. Originally approved in 1951. Last previous edition approved in 2012 as D409 – 12^{e1}. DOI: 10.1520/D0409_D0409M-16.

² For information concerning the experimental work on which this test method is based, see paper by Hardgrove, R. M., "Grindability of Coal," *Transactions, American Society of Mechanical Engineers*, Vol 54, F.S.P., p. 37, 1932.

D05.07 on Physical Characteristics on Coal is conducting ongoing investigations in regard to quality control during preparation, distribution, and use of standard reference materials and during preparation and testing of actual samples.

1.3 This standard does not purport to address all of the safety concerns, if any, associated with its use. It is the responsibility of the user of this standard to establish appropriate safety and health practices and determine the applicability of regulatory limitations prior to use.

2. Referenced Documents

2.1 ASTM Standards:³

- D2013 Practice for Preparing Coal Samples for Analysis
- D2234/D2234M Practice for Collection of a Gross Sample of Coal
- D3302 Test Method for Total Moisture in Coal
- D4749 Test Method for Performing the Sieve Analysis of Coal and Designating Coal Size
- D6609 Guide for Part-Stream Sampling of Coal
- D6708 Practice for Statistical Assessment and Improvement of Expected Agreement Between Two Test Methods that Purport to Measure the Same Property of a Material
- D6883 Practice for Manual Sampling of Stationary Coal from Railroad Cars, Barges, Trucks, or Stockpiles
- D7430 Practice for Mechanical Sampling of Coal
- E11 Specification for Woven Wire Test Sieve Cloth and Test Sieves

2.2

- ISO 13909 Hard Coal and Coke—Mechanical Sampling
- ISO 18283 Hard Coal and Coke—Manual Sampling
- ISO 3310-1 Test Sieves—Technical Requirements and Testing, Part 1: Test Sieves of Metal Wire Cloth
- ISO 17043 Conformity Assessment—General Requirements for Proficiency Testing

3. Significance and Use

3.1 This test method develops a measurement of grinding or pulverizing characteristics that can be used to evaluate the yield, or energy input, or both, required in a grinding or pulverizing process, which can impact a wide variety of processes, including combustion, coke-making, liquefaction, and gasification.

4. Apparatus

4.1 *Air-Drying Oven [for air-drying the 1000 g, 4.75 mm (No. 4) sample]*—A device for passing slightly heated air over the sample. The oven shall be capable of maintaining a temperature of 10 to 15 °C [18 to 27 °F] above room temperature with a maximum oven temperature of 40 °C [104 °F] unless ambient temperature is above 40 °C, in which case ambient temperature shall be used. In the case of easily oxidized coals, the temperature shall not be over 10 °C [18 °F] above room temperature unless ambient temperature is above 37 °C [100 °F] in which case ambient temperature shall be used. Air changes shall be at the rate of 1 to 4 air volumes of oven capacity per minute.

³ For referenced ASTM standards, visit the ASTM website, www.astm.org, or contact ASTM Customer Service at service@astm.org. For *Annual Book of ASTM Standards* volume information, refer to the standard's Document Summary page on the ASTM website.

4.2 *Drying Pans [for air-drying the 1000 g, 4.75 mm (No. 4) sample]*—Drying pans of sufficient size so that the sample may be spread to a depth of not more than 25 mm [1.0 in.] with sides not more than 38 mm [1.5 in.] high. The pans shall be nonreactive with coal and unaffected by the method of air drying selected.

4.3 *Balance [for weighing the 1000-g sample before and after air-drying and the sieve fractions formed during stage-crushing]*—With a sensitivity of at least 0.5 g in 1000 g and sufficient capacity to weigh a sample with a mass of greater than or equal to 1000g along with the drying pan.

4.4 *Balance [for weighing the 50-g test sample and the sieve fractions formed during milling]*—With a sensitivity of at least 10 mg and a minimum capacity of 800 g.

NOTE 1—A single balance meeting the specifications of 4.3 and 4.4 is permitted.

4.5 *Calibration Weights*—These calibration weights shall be used periodically to monitor the response of each balance over the working range.

4.6 *Sample Divider*—An enclosed riffle divider with feed chute as described in Practice D2013 or a rotary sample divider, which has been proven to be free of significant bias, may be used.

4.7 *Standard Sieves*—A working set of circular, standard testing sieves, which are 200 mm [8 in.] in diameter and conform to Specification E11 or ISO 3310-1, series R 40/3, are required in the following sizes, together with cover and catch pan (receiver):

TABLE 1 Standard Sieves for HGI Testing

| E11 Specification | U.S.A. Standard Sieve Series Designation |
|-------------------|--|
| 16.0 mm | 5/8 in. |
| 4.75 mm | No. 4 |
| 2.36 mm | No. 8 |
| 1.18 mm | No. 16 |
| 600 μm | No. 30 |
| 75 μm | No. 200 |

4.7.1 These working sieves must be periodically inspected for wear or damage. Any excessively worn or damaged sieves (for example, sieves with holes, tears, cracks; etc.) must be replaced immediately, and the HGI calibration procedure must be repeated after the damaged sieves are replaced (see Annex A5). Since the HGI depends upon the sieve analysis and since the 75-μm (No. 200) sieve is fragile, it is recommended that at least one set of working sieves be obtained, identified, and used exclusively for HGI determinations and that only this exclusive set of sieves be used for determining HGI.

4.7.1.1 Excessive wear may be indicated by poor repeatability or by failure of quality control checks (A5.4.1.1) to agree reasonably with the initial calibration data.

4.7.2 Normal wear on sieves is compensated by the use of primary HGI standard reference samples (HGI RMs) and proper calibration of equipment; excessive wear (such as holes or tears in the sieve cloth, and so forth) is not compensated by HGI RMs. Because excessive wear is unacceptable, inspect sieves carefully before each test to ensure the absence of excessive wear. For the 75- and 600-μm (No. 200 and 30) sieves, use only a soft-bristled brush (such as short-bristled camel hair) for brushing and cleaning.

4.7.2.1 It is good practice to keep a separate primary 75- μm (No. 200) check sieve to be used only to check the 75- μm (No. 200) working sieves described in 4.7.1 whenever the working sieve becomes suspect. This check is done by running a comparative HGI test between the two 75- μm (No. 200) sieves. Use of the working sieve for HGIs should be discontinued if HGI difference between the sieves is greater than 1 HGI unit.

4.8 *Plate Mill Crusher*—A laboratory plate mill capable of reducing 4.75-mm (No. 4) sieve size coal particles with the production of a minimum of minus 0.60-mm (minus No. 30) sieve size material. The crusher plates shall be serrated and about 100 mm [4 in.] in diameter. The distance between the plates shall be adjustable, and the relative speed of rotation of the plates shall not exceed 200 r/min.

4.8.1 Evidence from HGI standard reference sample user-response forms (A5.4.4) indicates that the median value of % Yield (8.3) of the 4.75-mm (No. 4) material as 1.18×0.60 mm (No. 16 \times 30) material, regardless of the HGI level, is about 55 %. Use this median value to gage the effectiveness/efficiency of the stage-crusher and of the stage-crushing process, while noting that, in some situations, the % Yield has been as low as 45%.

4.8.2 The most frequently used plate mill can be equipped with “fine” or “coarse” plates. One independent study⁴ has found evidence of differences in percent recovery resulting from use of different types of plate. In order to obtain the maximum % Yield, only the coarse plate should be used in preparation of both HGI calibration standards and unknown samples.

4.9 *Mechanical Sieving Machine*—The mechanical sieving machine shall accept an assembly of vertically nested circular sieves of 200 mm [8 in.] in diameter, together with cover and receiver. The machine shall simulate the motions given testing sieves during hand sieving by imparting a horizontal oscillatory motion of approximately 28-mm [1.1-in.] amplitude at a rate of approximately 300 oscillations or cycles per minute (cpm). Simultaneously, the top of the oscillating assembly is struck at a rate of approximately 150 blows per minute by a mass of 1.9 kg [4.2 lb] moving through a vertical distance of approximately 28 mm [1.1 in.] under the influence of gravity.

4.9.1 Whenever a mechanical sieving machine other than the reference machine described above is used, the method may be shown to be equivalent by one of two methods (1) side x side equivalency testing of the alternative machine vs. the reference machine (with both calibration and test samples that cover the working range), using the equivalency testing statistical technique of D6708 or (2) acceptable performance in an appropriate proficiency test program that covers the working range and that is accredited to ISO 17043.

4.9.1.1 “Acceptable” performance shall be defined by the proficiency test provider.

4.10 *Grindability Machine*—The Hardgrove Grindability Machine such as is shown in Fig. 1 is required for this test. Essential tolerances and specifications are shown in Fig. 2. The grindability machine includes a stationary grinding bowl of

polished cast iron, with a circular horizontal track that holds eight polished steel balls, each 25.40 ± 0.13 mm [1.000 ± 0.005 in.] in diameter. The balls are driven by an upper grinding ring which is rotated at 20 ± 1 r/min by means of the upper spindle and which, in turn, is driven by an electric motor through reduction gears or, in newer models, belts. Weights are added to the driving spindle so that the total vertical force on the balls as a result of the weights, shaft, top grinding ring, and gear is equal to 29.0 ± 0.2 kg [64 ± 0.5 lb]. The machine is equipped with a counter and automatic device, which can be properly adjusted for stopping the machine after 60 ± 0.25 revolutions.

4.10.1 It is good laboratory practice to have the dimensions and the tolerances components that are subject to wear verified on a periodic basis.

4.10.2 The position of the counter trip mechanism before and after the test must be used to determine the number of revolutions completed. With some machines, it may be necessary to position strategically the counter trip mechanism at the beginning of the test to accomplish the desired number of revolutions (that is, during a set-up period, watch where the trip mechanism is initially, count the number of revolutions from the point of origin, determine where the trip mechanism is at the end of the test, and determine if the specified 60 ± 0.25 revolutions are obtained. If not, adjust the position of the trip mechanism at the beginning of the test until the specified number of revolutions are obtained). Periodically, verify that the machine is operated to obtain the specified number of revolutions per test.

5. Gross Samples

5.1 Collect a gross sample of coal, representative of the material from which it is taken. The sample may be collected, in accordance with Practice D2234/D2234M, D6883, D6609, or D7430; or ISO 13909 or 18283 (or equivalent other international or national standard), and prepared in accordance with Practice D2013; or ISO 13909 or 18283 (or equivalent other international or national standard) except that the sample topsize shall not be reduced beyond the 4.75-mm (No. 4) sieve and the sample shall have a mass of at least 1000 g.

5.2 If the topsize of the final sample product produced from mechanical sampling system is smaller than 4.75mm (No. 4), the sample does not meet the requirements of this test procedure.

6. Preparation of Test Samples

6.1 Prepare a 1.18×0.60 mm (No. 16 \times 30) test sample for establishing the HGI of HGI RMs (Annex A4), for calibration (Annex A5), or for routine determination of HGI.

6.2 When necessary, divide the quantity of 4.75-mm (No. 4) sieve size coal to not less than 1000-g lots using an enclosed riffle or rotary sample divider, and air dry each sample in conformance with Test Method D3302. To calculate the % Yield (8.3), record the mass of the air-dried sample (m_1).

6.3 Sieve the entire amount (1000 g) of air-dried 4.75-mm (No. 4) sieve size sample in lots of no greater than 250 g for $2 \text{ min} \pm 10 \text{ s}$ in the mechanical sieving machine. Use a set of

⁴ D05.07 Minutes, J. Gardner, Georgia Power and G. Linton, October 1990.

FIG. 1 Hardgrove Grindability Machine

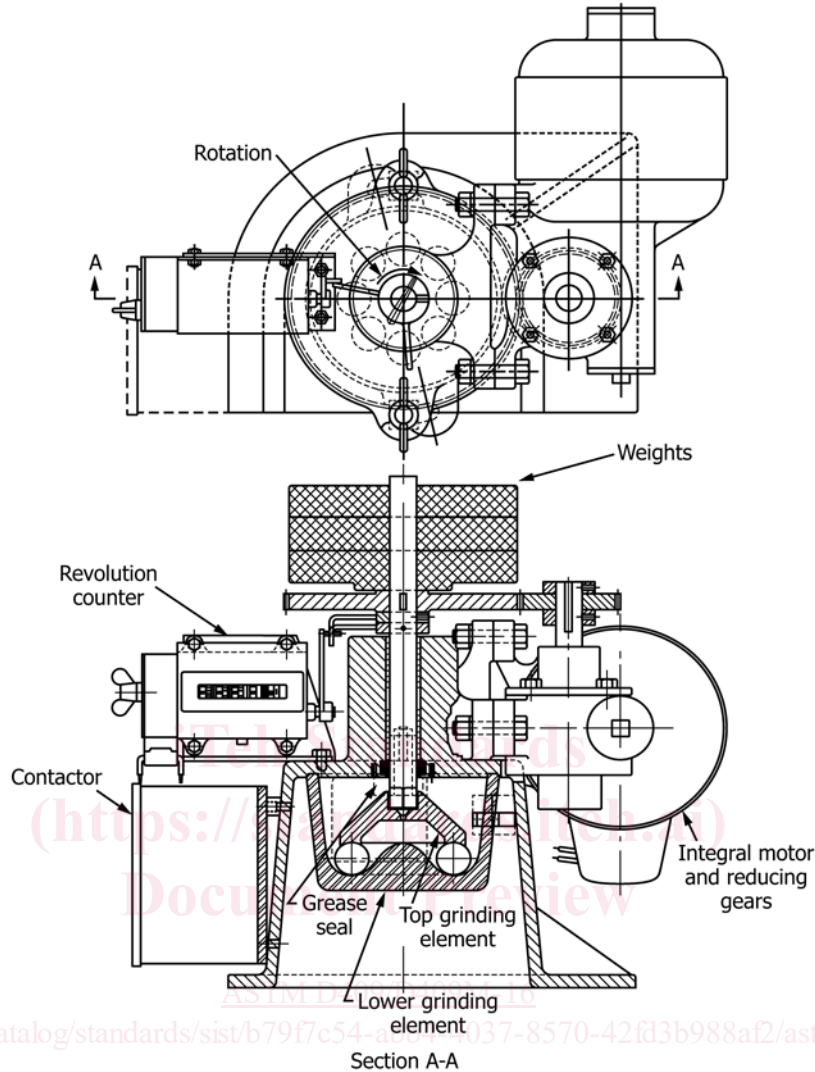

<https://standards.iteh.ai/catalog/standards/sist/b79f7c54-837-8570-42fd3b988af2/astm-d409-d409m-16>

| Item | Mass, kg | Mass, lb |
|----------------|------------------|------------|
| Lead | 25.9 | 57.0 |
| Shaft and Gear | 2.0 [†] | 4.5 |
| Top Ring | 1.1 | 2.5 |
| Total | 29.0 ± 0.2 | 64.0 ± 0.5 |

[†] Editorially corrected in February 2012.

nested sieves consisting of a 1.18-mm (No. 16) sieve on top of a 0.60-mm (No. 30) sieve. Weigh and record the mass of each sieve size.

6.3.1 Include a 4.75-mm (No. 4) and a 2.36-mm (No. 8) sieve in this nest of sieves to ease separation, determine and record the “natural” particle size distribution, and to verify that the topsize of the sample is appropriate for this test. Sieving more than 250 g at a time on the 200-mm [8-in.] diameter sieve may not allow each particle to “see” the sieve surface and have an opportunity to pass or to be retained by the sieve.

6.4 Combine and stage crush all of the sieve fractions greater than the 1.18-mm (No. 16) sieve with the crusher adjusted so that only the largest particles are crushed. Sieve the

crushed material in portions of no greater than 250 g for 2 min ± 10 s in the mechanical sieving machine. Return the oversize to the crusher, after setting the crusher so that only the largest particles are crushed. Continue the stage crushing and sieving procedure until all the material passes the 1.18-mm sieve. Retain the 1.18 × 0.60 mm (No. 16 × 30) material. After all stage-crushing is completed, to calculate the % Yield (8.3), record the mass of the 1.18 × 0.60 mm (No. 16 × 30) fraction (m_2).

6.5 Mix well all the 1.18 × 0.60 mm (No. 16 × 30) material accumulated from the stage crushing and sieving process and divide the quantity using an enclosed riffle or rotary sample divider to obtain approximately 120 ± 10 g.

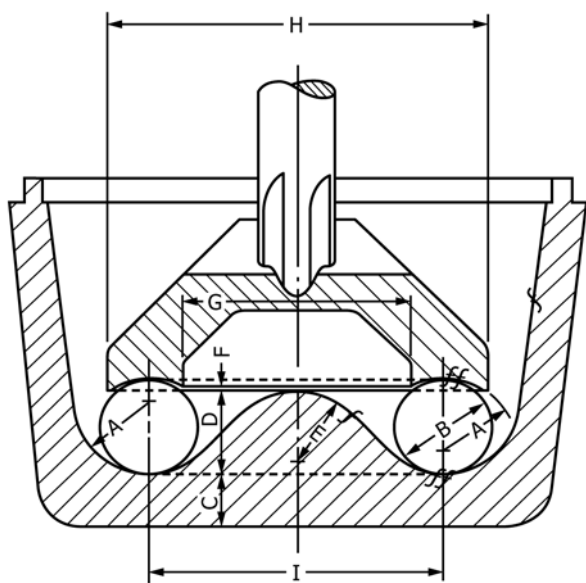

- A = 19.05 ± 0.13 mm [0.750 ± 0.0005 in.] radius
- B = 25.40 ± 0.13 mm [1.000 ± 0.0005 in.] diameter
- C = 12.70 mm [0.50 in.]
- D = 22.23 mm [0.875 in.]
- E = 19.05 mm [0.750 in.]
- F = 1.42 mm [0.078 in.]
- G = 60.33 mm [2.375 in.]
- H = 98.43 mm [3.875 in.]
- I = 76.20 mm [3.000 in.]
- f = smooth machine surface
- ff = fine machined surface and polished

FIG. 2 Grinding Elements of Hardgrove Machine

6.6 As the final step in preparation of the test sample, dedust the 120 ± 10-g sample from 6.5 by sieving on a 0.60 mm (No. 30) sieve for 5 min ± 10 s using the mechanical sieving machine.

6.6.1 Determining the mass of each sieve fraction after each stage-crushing step will allow the rate of reduction to be calculated and evaluated as a contributor to achieving adequate % Yield.

7. Procedure

7.1 Clean the grindability machine thoroughly, place the machine on a level surface, and space the balls as evenly as possible around the grinding bowl. Set the automatic stopping device so that the motion of the grindability machine will stop after 60 ± 0.25 revolutions of the upper grinding ring.

7.1.1 If the grindability machine makes a different number of revolutions other than the specified 60 ± 0.25 revolutions, the machine must be adjusted to within the tolerance specified. (This is normally done by strategically placing the counter tripper arm at the start of the test. See 4.10.2.)

7.2 Weigh 50 ± 0.01 g of the 1.18 × 0.60 mm (No. 16 × 30) sieve size dedusted material from 6.6 and distribute it evenly in the grinding bowl, brushing any material that falls on the elevated section of the lower grinding element into the lower

grinding element, which contains the balls. Fasten the bowl in position and make sure the load is fully applied to the driving spindle.

7.3 Operate the machine for the specified 60.00 ± 0.25 revolutions.

7.4 Remove the bowl from the machine, lift out the upper grinding ring, and carefully brush adhering coal dust from the bowl and grinding ring onto a 16-mm [5/8-in.] sieve nested on a 75-µm (No. 200) sieve and a closely fitting receiving pan. Carefully empty the contents of the bowl onto the 16-mm [5/8-in.] sieve. Brush off material adhering to the balls and remove the balls from the 16-mm [5/8-in.] sieve. Brush material adhering to the 16-mm [5/8-in.] sieve, including the underside of the sieve, onto the 75-µm (No. 200) sieve. Replace the 16-mm [5/8-in.] sieve with a close-fitting cover and shake the nested 75-µm (No. 200) sieve; cover and pan for 10 min ± 10 s in a mechanical sieving machine. After the 10-min ± 10-s period, carefully brush coal dust from the underside of the 75-µm (No. 200) sieve into the receiving pan using a soft-bristled brush to avoid damaging the sieve. Repeat the shaking of the ball-milled material and the cleaning of the underside of the 75-µm (No. 200) sieve for two more periods each of 5-min ± 10-s duration.

7.4.1 Before emptying the contents of the lower grinding bowl onto the 16-mm [5/8-in.] sieve, the tops of the grinding balls may be brushed and then the balls may be removed from the lower grinding bowl by use of a magnetic extraction tool. Each grinding ball is brushed off and set aside; then, the pulverized coal is emptied from the bowl onto the 16-mm [5/8-in.] sieve.

7.5 Weigh separately to the nearest 0.01 g the coal retained on the 75-µm (No. 200) sieve (m_3) and the coal passing the 75-µm (No. 200) sieve (m_4).

7.5.1 Alternatively, predetermine the tare masses of the 75-µm (No. 200) sieve (m_5) and the catch pan (m_6). After the sieving of 7.4, weigh the 75-µm (No. 200) sieve and its contents (m_7). Subtract the tare mass to obtain the mass of the +75-µm (+No. 200) material = $m_3 = m_7 - m_5$. Weigh the catch pan and its contents (m_8). Subtract the tare mass to obtain the mass of the -75-µm (-No. 200) material = $m_4 = m_8 - m_6$.

7.6 If the sum of the +75-µm (+No. 200) (m_3) and the -75-µm (-No. 200) (m_4) sieve fraction masses differs by more than 0.50 g from the initial mass of 50 ± 0.01 g (m_0 , see 7.2), reject the test and repeat. Use the calculated mass of the coal passing the 75-µm (No. 200) sieve (m_{10}), determined by subtracting the mass retained on the 75-µm (No. 200) sieve (m_3) from the test specimen mass (m_0), in determining the sum-of-least-squares fit (A5.4.3), in preparation of the calibration chart (A5.4.3.2) or in calculation of the grindability index of the sample (8.1) $m_{10} = m_0 - m_3$.

8. Calculation and Report

8.1 Calculate the grindability index corresponding to the calculated mass of test specimen passing the 75-µm (No. 200) sieve (7.5) directly from the equation of the line prepared in A5.4.3 and report to the nearest whole number.



D409/D409M – 16

| | | |
|--|--|----------------|
| Sample I.D.: _____ | Date: _____ | Analyst: _____ |
| Sample Description: _____ | | |
| AIR-DRYING | | |
| Air-dry pan mass, (a) : _____ g | Ambient Temp : _____ °C [°F] | |
| Initial sample and air-dry pan mass, (b) : _____ g | Time into oven : _____ | |
| Final sample and air-dry pan mass, (c) : _____ g | Time out of oven : _____ | |
| Air-dried sample mass, c – a, (d) : _____ g | Temperature : _____ °C [°F] | |
| Mass loss on drying, b – c, (e) : _____ g | Heat on at : _____ | |
| Initial sample mass, b – a, (f) : _____ g | Heat off at : _____ | |
| % Mass loss on drying, e/f × 100%, (g) : _____ % | Fan on at : _____ | |
| | Fan off at : _____ | |
| INITIAL SIEVED MASSES | | |
| +4.75 mm (+No.4), (h) : _____ g | 1.18 × 0.600 mm (No.16 × 30), (k) : _____ g | |
| 4.75 × 2.36 mm (No.4 × 8), (i) : _____ g | -0.600 mm (-No.30), (l) : _____ g | |
| 2.36 × 1.18 mm (No.8 × 16), (j) : _____ g | Topsize : _____ | |
| Total recovered mass after sieving, (h + i + j + k + l), (m) : _____ g | | |
| Mass loss on sieving, d – m, (n) : _____ g | | |
| % Mass loss on sieving, (n/d) × 100%, (o) : _____ % | | |
| REDUCTION OF +1.18 mm (+No. 16) | | |
| Mass, +1.18 mm (+No. 16) | Mass, +1.18 mm (+No. 16) | |
| Initially, h + i + j, (p) : _____ g | >6th crushing of oversize, (v) : _____ g | |
| >1st crushing of oversize, (q) : _____ g | >7th crushing of oversize, (w) : _____ g | |
| >2nd crushing of oversize, (r) : _____ g | >8th crushing of oversize, (x) : _____ g | |
| >3rd crushing of oversize, (s) : _____ g | >9th crushing of oversize, (y) : _____ g | |
| >4th crushing of oversize, (t) : _____ g | >10th crushing of oversize, (z) : _____ g | |
| >5th crushing of oversize, (u) : _____ g | | |
| Final total mass of 1.18 × 0.600 mm (No. 16 × 30), (A) : _____ g | | |
| Final total mass of -0.600 mm (-No. 30), (B) : _____ g | | |
| Final total recovered mass, (A+B), (C) : _____ g | | |
| Loss on crushing, (m-C), (D) : _____ g | | |
| % loss on crushing, (D/d) × 100%, (E) : _____ % | | |
| % Yield of 1.18 × 0.600 mm (No. 16 × 30), A/d × 100%, (F) : _____ % | | |
| DEDUSTING 120 g OF 1.18 × 0.60 mm (No. 16 × No. 30) and Milling | | |
| Mass of 1.18 × 0.60 mm (No. 16 × 30) dedusted sample placed into HGI bowl, (G) : _____ g | Number of revolutions, (I) : _____ | |
| No. of increments collected, (H) : _____ | Seconds to mill, (J) : _____ sec | |
| Start position : _____ | RPM, [I/(J/60)] : _____ RPM | |
| Stop position : _____ | | |
| Start time : _____ | | |
| Stop time : _____ | | |
| SIEVING OF MILLED PRODUCT | | |
| Tare mass of catch pan, (L) : _____ g | Mass of -75 µm (-No. 200), (N – L), (P) : _____ g | |
| Tare mass of 75 µm (No 200) sieve, (M) : _____ g | Mass of +75 µm (+No. 200), (O – M), (Q) : _____ g | |
| Mass of catch pan and -75 µm (-No. 200), (N) : _____ g | Total recover, (P + Q), (R) : _____ g | |
| Mass of 75 µm (No 200) sieve and +75 µm (+No. 200), (O) : _____ g | Loss (≤0.50 g), (G – R), (S) : _____ g | |
| Calculated mass of -75 µm (-No. 200), (G – Q), (T) : _____ g | | |
| ANALYTICAL RESULTS | | |
| HGI Formula (from Least Squares Regression) : _____ | | |
| HGI (U) : _____ | | |
| % moisture on 1.18 × 0.600 mm (No. 16 × 30) material : _____ % | <i>See the ANNEX, Method for Determining the Moisture Content of the 1.18 × 0.600 mm (No. 16 × 30) Test Sample</i> | |

FIG. 3 HGI Log Sheet is for Example Only and is Non-Mandatory