



Designation: F2236 – 16a

Standard Consumer Safety Specification for Soft Infant and Toddler Carriers¹

This standard is issued under the fixed designation F2236; the number immediately following the designation indicates the year of original adoption or, in the case of revision, the year of last revision. A number in parentheses indicates the year of last reapproval. A superscript epsilon (ϵ) indicates an editorial change since the last revision or reapproval.

INTRODUCTION

This consumer safety specification is intended to address incidents reported by the U.S. Consumer Product Safety Commission (CPSC) relating to soft infant carriers.

In response to the incident data compiled by the CPSC, this consumer safety specification attempts to minimize the hazards associated with these products from the following: (1) occupant retention, (2) structural integrity, (3) deficiency of consumer education regarding product use. This consumer safety specification is intended to deal with reasonably foreseeable use and misuse of the products. This consumer safety specification does not apply to products that are blatantly misused, nor does it apply to products used by consumers in a careless manner that violate normal practice or disregard the instructions or warnings provided with the product, or both.

1. Scope

1.1 This consumer safety specification establishes performance requirements, test methods and marking requirements to promote safe use of soft infant and toddler carriers.

1.2 This consumer safety specification is intended to minimize the risk of incidents to an infant from the normal use and reasonably foreseeable misuse of these products.

1.3 For purposes of definition, a soft infant and toddler carrier is a product, normally of sewn fabric construction, which is designed to contain a full term infant to a toddler, generally in an upright position, in close proximity to the caregiver. In general, the child will weigh between 7 and 45 lb (3.2 and 22 kg). The soft infant and toddler carrier is normally “worn” by the caregiver with a child positioned in the carrier and the weight of the child and carrier suspended from one or both shoulders of the caregiver. These products may be worn on the front, side, or back of the caregiver’s body with the infant either facing towards or away from the caregiver. This consumer safety specification does not include products generally referred to as “slings.”

1.4 No soft infant and toddler carrier produced after the approval date of this consumer safety specification shall, either by label or other means, indicate compliance with the specification unless it complies with all of the requirements contained herein.

¹ This consumer safety specification is under the jurisdiction of ASTM Committee F15 on Consumer Products and is the direct responsibility of Subcommittee F15.21 on Infant Carriers, Bouncers and Baby Swings.

Current edition approved Sept. 1, 2016. Published September 2016. Originally approved in 2003. Last previous edition approved in 2016 as F2236 – 16. DOI: 10.1520/F2236-16A.

1.5 This consumer safety specification is not intended to address incidents and injuries resulting from the interaction of other persons or objects with the caregiver and infant while the soft carrier is in use.

1.6 The values stated in inch-pound units are to be regarded as standard. The values given in parentheses are mathematical conversions to SI units that are provided for information only and are not considered standard.

1.7 The following precautionary caveat pertains only to the test method portion, Section 7 of this consumer safety specification. *This standard does not purport to address all of the safety concerns, if any, associated with its use. It is the responsibility of the user of this standard to establish appropriate safety and health practices and determine the applicability of regulatory requirements prior to use.*

2. Referenced Documents

2.1 *ASTM Standards:*²

[D3359 Test Methods for Measuring Adhesion by Tape Test](#)
[F963 Consumer Safety Specification for Toy Safety](#)
[F977 Consumer Safety Specification for Infant Walkers](#)

2.2 *Federal Regulations:*³

[16 CFR 1303 Ban of Lead-Containing Paint and Certain Consumer Products Bearing Lead-Containing Paint](#)
[16 CFR 1500 Hazardous Substance Act Regulations](#)

² For referenced ASTM standards, visit the ASTM website, www.astm.org, or contact ASTM Customer Service at service@astm.org. For *Annual Book of ASTM Standards* volume information, refer to the standard’s Document Summary page on the ASTM website.

³ Code of Federal Regulations, available from U.S. Government Printing Office, Washington, DC 20402.

- 16 CFR 1500.3(c)(6)(vi) Definition of “Flammable Solid”
- 16 CFR 1500.44 Method for Determining Extremely Flammable and Flammable Solids
- 16 CFR 1500.48 Technical Requirements for Determining a Sharp Point in Toys or Other Articles Intended for Use By Children Under Eight Years of Age
- 16 CFR 1500.49 Technical Requirements for Determining a Sharp Metal or Glass Edge in Toys or Other Articles Intended for Use By Children Under Eight Years of Age
- 16 CFR 1500.50-.51 Test Methods for Simulating Use and Abuse of Toys and Other Articles for Use by Children
- 16 CFR 1501 Method for Identifying Toys and Other Articles Intended for Use by Children Under Three Years of Age Which Present Choking, Aspiration or Ingestion Hazards Because of Small Parts
- 16 CFR 1610 Standard for the Flammability of Clothing Textiles

3. Terminology

3.1 Definitions:

3.1.1 *carrying position*—the location on the caregiver’s torso where the child is supported by the soft carrier. The most common carrying positions are front, back, and side/hip.

3.1.2 *conspicuous*—label which is visible when the product is in the manufacturer’s use position to a caregiver who is placing the occupant in the soft carrier or when the caregiver places the product on his or her body.

3.1.3 *cord*—length of slender, flexible material including monofilaments, rope, woven and twisted cord, plastic or textile tapes, ribbons and those fibrous materials commonly called string.

3.1.4 *dynamic load*—application of impulsive force through free fall of a weight.

3.1.5 *fabric*—any woven, knit, coated, laminated, extruded or calendared flexible material that is intended to be sewn, welded, heat sealed, or glued together as an assembly.

3.1.6 *fastener*—mechanical means of attachment that may also allow for adjustments of the product fit to wearer and occupant including, but not limited to, buckles, snaps, rings, D-rings, hook-and-loop, etc., and excluding fabric-only means of attachment and fit adjustment such as, but not limited to, consumer-tied knots.

3.1.7 *leg opening*—opening in the soft carrier through which the occupant’s legs extend when the product is used in the manufacturer’s recommended use position.

3.1.8 *manufacturer’s recommended use position(s)*—any position that is presented as a normal, allowable, or acceptable configuration for use of the product by the manufacturer in any descriptive or instructional literature. This specifically excludes positions that the manufacturer shows in a like manner in its literature to be unacceptable, unsafe or not recommended.

3.1.9 *non-paper label*—any label material (such as plastic or metal) that either will not tear without the aid of tools or tears, leaving a sharply defined edge.

3.1.10 *occupant*—that individual who is placed or carried in the soft carrier product in one of the manufacturer’s recommended use positions.

3.1.11 *paper label*—any label material which tears without the aid of tools and leaves a fibrous edge.

3.1.12 *primary load bearing fastener*—any fastener which provides support for the child or is used to attach that support of the child to the caregiver, or both, that is subject to the direct force of the occupant load, including those fasteners associated with positioning or supporting the child’s torso within the carrier.

3.1.13 *seam*—means of joining fabric components, such as sewing, welding, heat sealing, or gluing.

3.1.14 *secondary load bearing fastener*—any fastener which provides aid to the wearer for positioning primary load bearing components (for example, sternum strap fasteners). Such fasteners are subject to forces less than those exhibited by the direct occupant load in intended/foreseeable use.

3.1.15 *static load*—vertically downward force applied by a calibrated force gage or by dead weights.

3.1.16 *unbounded leg opening*—leg opening created by placing the soft carrier on a caregiver’s torso and which has an opening circumference composed solely of carrier materials and the caregiver’s torso.

4. Calibration and Standardization

4.1 The product shall be completely assembled in accordance with the manufacturer’s instructions.

4.2 No testing shall be conducted within 48 h of manufacture.

4.3 The product to be tested shall be at an ambient temperature of $73 \pm 9^\circ\text{F}$ ($23 \pm 5^\circ\text{C}$) for at least one hour before testing. All testing shall be conducted in this temperature range.

4.4 All testing required by this consumer safety specification shall be conducted on the same unit in the order presented in this specification unless otherwise specified (see 7.2).

5. General Requirements

5.1 *Hazardous Sharp Points or Edges*—There shall be no sharp points or edges as defined by 16 CFR 1500.48 and 16 CFR 1500.49 before and after testing.

5.2 *Small Parts*—There shall be no small parts as defined by 16 CFR 1501 before testing or liberated as a result of testing to this specification.

5.3 *Lead in Paint*—The paint or surface coating on the product shall comply with 16 CFR 1303.

5.4 *Wood Parts*—Prior to testing, any wooden parts shall be smooth and free of splinters.

5.5 *Locking and Latching*—Any product designed with a locking and latching device must remain in the manufacturer’s recommended use position before and after completion of all tests in this standard.

5.6 *Labeling*—Warning labels (whether paper or non paper) shall be permanent when tested per 7.3 – 7.5.

5.6.1 Warning statements applied directly onto the surface of the product by hot stamping, heat transfer, printing, wood burning, and so forth shall be permanent when tested in accordance with 7.4.

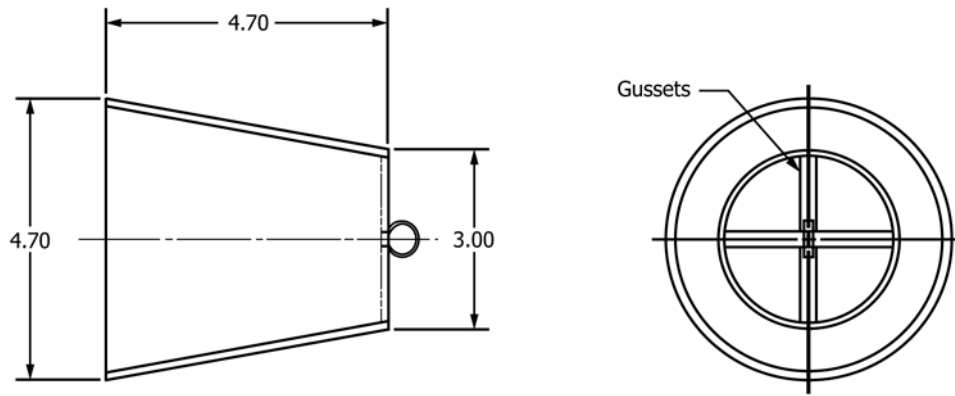

FIG. 1 Truncated Test Cone

5.6.2 Non-paper labels shall not liberate small parts when tested in accordance with 7.5.

5.7 *Flammability of Textile Products:*

5.7.1 There shall be no Class 2 or 3 fabrics used in the construction of a soft infant and toddler carrier when the product is evaluated against the requirements of 16 CFR 1610.

5.7.2 If a soft infant and toddler carrier is incapable of being evaluated to the requirements of 16 CFR 1610 due to construction characteristics, the product shall not be flammable as defined under 16 CFR 1500.3(c)(6)(vi) when tested in accordance with Consumer Safety Specification F963, Annex 5.

5.8 *Toys*—Toy accessories attached to, removable from, or sold with a soft infant carrier, as well as their means of attachment, must meet applicable requirements of Consumer Safety Specification F963.

6. Performance Requirements

6.1 *Leg Openings*—Leg openings shall not permit the passage of the Leg Opening Test Sphere when tested in accordance with 7.1.

6.2 *Dynamic and Static Load:*

6.2.1 *Structural Integrity*—Dynamic and static load testing shall not result in a hazardous condition as defined in Section 5 or result in a structural failure such as fasteners breaking or disengaging, or seams separating when tested in accordance with 7.2.1 and 7.2.2, respectively.

6.2.2 *Support/Shoulder Strap Slippage*—Adjustable sections of support/shoulder straps shall not slip, in a manner that loosens the strap, more than 1 in. (25 mm) per strap from their original adjusted position after dynamic and static load testing is performed in accordance with 7.2.1 and 7.2.2, respectively.

6.3 *Unbounded Leg Opening*—Leg opening shall not allow complete passage of the truncated test cone (see Fig. 1) when tested according to 7.6.

6.4 *Fastener Strength and Strap Retention:*

6.4.1 Each unique primary load bearing fastener shall not break or disengage, and adjustable elements in straps shall not slip, in a manner that loosens the strap, more than 1 in. (2.5 cm) when tested in accordance with 7.7.1 and 7.7.2.

6.4.2 Each unique fastener whose primary purpose is to adjust the size of the leg opening, or is a secondary load

bearing fastener, shall not break or disengage, and adjustable elements in straps shall not slip, in a manner that loosens the strap, more than 1 in. (2.5 cm) when tested in accordance with 7.7.1 and 7.7.3.

NOTE 1—The requirements in 6.4 only apply to load bearing fasteners and leg opening adjustment fasteners. Non-load bearing fasteners intended to retain accessory items such as, but not limited to, sleeping hoods, bibs, toy rings etc., or fasteners which do not provide support or securement of the child’s torso within the carrier (for example, head adjustment fasteners) are exempt from these requirements.

7. Test Methods

7.1 *Leg Openings:*

7.1.1 Fasten the soft carrier to a rigid fixture in a manner such that the leg opening of the carrier is horizontal. The opening shall be as close to the center of the fixture as possible. If the leg opening is adjustable in size to allow for growth, it shall be tested with the leg opening adjusted to its smallest size as described in the manufacturer’s literature or instructions.

7.1.2 Place the leg opening test sphere (see Fig. 2) inside the carrier and gradually allow the sphere to rest in the leg opening over a period of 5 s. Allow the sphere to rest in the opening for an additional 1 min.

7.1.3 Repeat the test for the other leg opening.

7.2 *Dynamic and Static Load Tests*—The dynamic and static tests in 7.2.1 and 7.2.2, respectively, shall be performed on the same product sample in each carrying position with a new product sample being tested for each different carrying position. For example, a product that may be worn on the front and back has two carrying positions therefore a minimum of two samples must be tested. One product sample shall be used for the front carrying position dynamic and static tests, and another for the back carrying position dynamic and static tests.

7.2.1 *Dynamic Load Test:*

7.2.1.1 *Equipment:* (1) *Shot Bag*—6 to 8 in. (152 to 203 mm) diameter shot bag with total mass of 25 lbm (11.3 kg) or a mass equal to the manufacturer’s recommended maximum occupant weight for the specific carrying position of the product, whichever is greater. A product with multiple carrying positions may have different manufacturer’s recommended maximum weights for each carrying position.

NOTE 2—Solid, cylindrical weights (Olympic-sized barbell weight

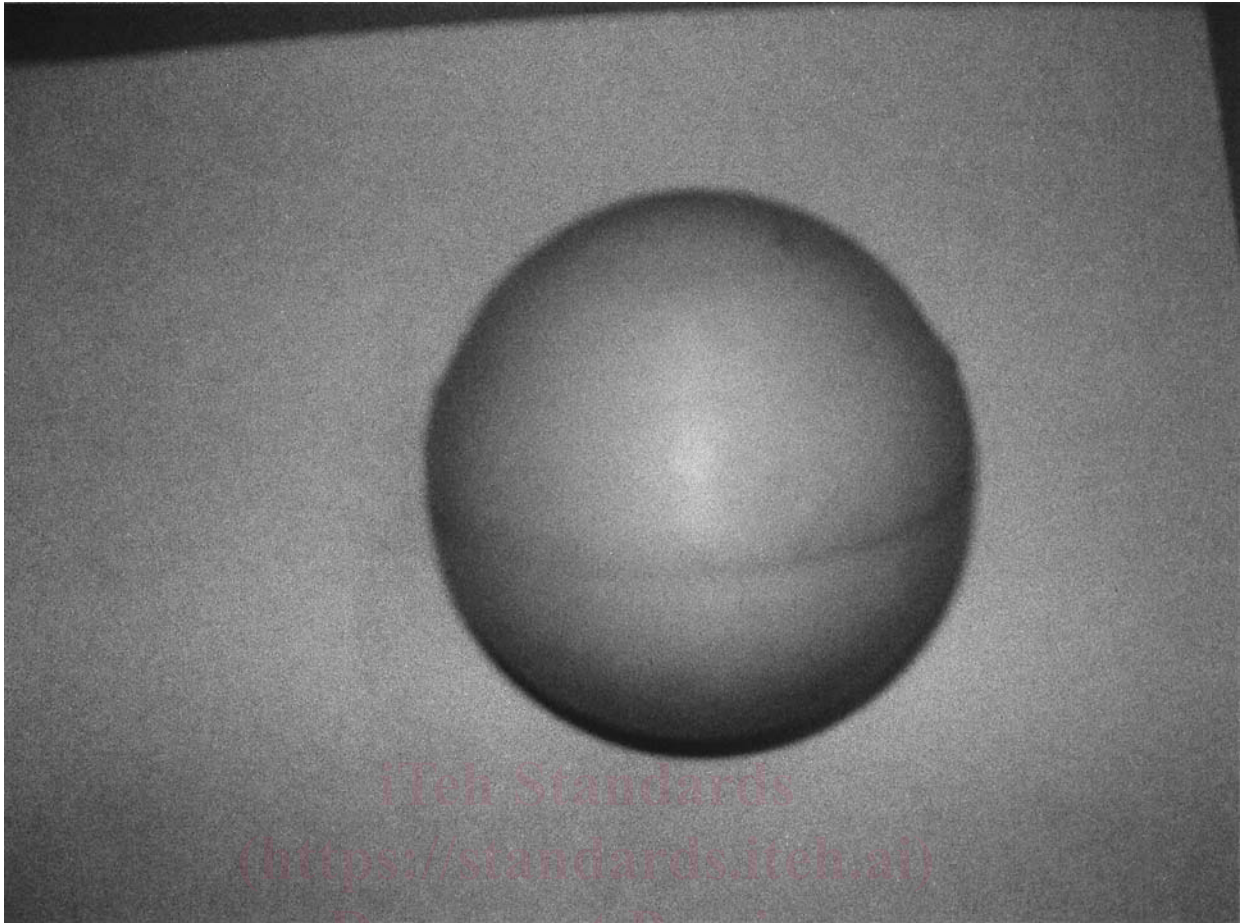

NOTE 1—Sphere shall be fabricated from a smooth, rigid material weighted to 5 lb (2.3 kg).

NOTE 2—Sphere is machined to 14.75 in. (374.6 mm) circumference.

FIG. 2 Leg Opening Test Sphere

plates, for example) may be secured on top of the 25 lbm (6.9 kg) shot bag when a greater total mass is required.

(2) *Test Torso*⁴— See Fig. 3.

7.2.1.2 Position, secure, and adjust the soft carrier onto the test torso⁴ according to the manufacturer’s instructions provided with the product.

7.2.1.3 Position the shot bag a distance of 1 in. (25 mm) above the seat of the soft carrier. Allow the shot bag to free fall onto the seat ten times with a cycle time of 4 ± 1 s/cycle to preset the adjustment(s) of the carrier on the test torso. By some appropriate means, mark the position of all adjustment hardware. This will be the reference point for measuring adjustment slippage in the test. Drop the shot bag onto the seat an additional 990 times with a cycle time of 4 ± 1 s/cycle. If

⁴ The sole source of supply of the test torso (called “Body Opponent Bag”) known to the committee at this time is Century Sporting Goods. It is available from various distributors on websites such as www.superfoots.com/cenbodopbagb, www.karate-mart.com, and karatedepot.com. If you are aware of alternative suppliers, please provide this information to ASTM International Headquarters. Your comments will receive careful consideration at a meeting of the responsible technical committee,¹ which you may attend.

the height location of the product on the test torso changes, adjust the test torso or product to maintain the 1 in. (25 mm) drop height.

7.2.2 *Static Load Test:*

7.2.2.1 *Equipment:*

(1) *Standard Weld Cap*—6 in. (150-mm) (see Fig. 4).

(2) *Test Torso*⁴—See Fig. 3.

7.2.2.2 Position, secure, and adjust the soft carrier onto the test torso according to the manufacturer’s instructions provided with the product.

7.2.2.3 Center the standard weld cap in the seat area of the soft carrier. Place a total weight of 75 lbm (34 kg) or three times the manufacturer recommended maximum occupant weight for the specific carrying position, whichever is greater, onto the weld cap. (Include the weight of the weld cap in the total weight.) Gradually apply the weight within a 5-s period and maintain for an additional 1 min.

7.3 *Permanency of Labels and Warnings:*

7.3.1 A paper label (excluding labels attached by a seam) shall be considered permanent if during an attempt to remove