



# Standard Test Methods for Cigarette Ignition Resistance of Components of Upholstered Furniture<sup>1</sup>

This standard is issued under the fixed designation E1353; the number immediately following the designation indicates the year of original adoption or, in the case of revision, the year of last revision. A number in parentheses indicates the year of last reapproval. A superscript epsilon ( $\epsilon$ ) indicates an editorial change since the last revision or reapproval.

<sup>ε1</sup> NOTE—The old Precision and Bias statement was removed editorially in July 2010 as a complete statement is now given in Section 22.

## 1. Scope Scope\*

1.1 This is a fire-test-response standard.

1.2 These test methods are designed for the assessment of the resistance of upholstered furniture component assemblies to combustion after exposure to smoldering cigarettes under specified conditions.

1.3 The tests apply to upholstered furniture components—cover fabrics, interior fabrics, welt cords, decking materials, barrier materials, and filling or padding materials including but not limited to: battings of natural or man-made fibers, foamed or cellular filling materials, resilient pads of natural or man-made fibers, and loose particulate filling materials (such as shredded polyurethane or feathers and down).

1.4 The individual test methods and the materials to which they apply are as follows:

1.4.1 *Cover Fabric Test*—Applies to outer cover fabrics (see Sections 10 and 11).

1.4.2 *Interior Fabric Test*—Applies to interior fabrics used in intimate contact with outer fabrics (see Sections 12 and 13).

1.4.3 *Welt Cord Test*—Applies to welt cord (see Sections 14 and 15).

1.4.4 *Filling/Padding Component Test*—Applies to resilient materials used under the cover fabric in seats or in inside vertical walls (inside arm and inside backs) (see Sections 16 and 17).

1.4.5 *Decking Materials Test*—Applies to resilient materials used in the deck under loose cushions (see Sections 18 and 19).

1.4.6 *Barrier Materials Test*—Applies to materials that are intended to serve as a barrier between cover fabric and conventional polyurethane foam (see Sections 20 and 21).

1.5 The values stated in inch-pound units are to be regarded as standard. The values given in parentheses are mathematical conversions to SI units that are provided for information only and are not considered standard.

1.6 *This standard is used to measure and describe the response of materials, products, or assemblies to heat and flame under controlled conditions, but does not by itself incorporate all factors required for fire hazard or fire risk assessment of the materials, products, or assemblies under actual fire conditions.*

1.7 *This standard does not purport to address all of the safety concerns, if any, associated with its use. It is the responsibility of the user of this standard to establish appropriate safety and health practices and determine the applicability of regulatory limitations prior to use. For specific hazard statements, see Section 7.*

## 2. Referenced Documents

2.1 *ASTM Standards:*<sup>2</sup>

[E176 Terminology of Fire Standards](#)

[E691 Practice for Conducting an Interlaboratory Study to Determine the Precision of a Test Method](#)

2.2 *Federal Specifications:*<sup>3</sup>

[Fed.Spec. CCC-C-436-D, Cloth, Ticking, Twill, Cotton; Type I](#)

<sup>1</sup> These test methods are under the jurisdiction of ASTM Committee E05 on Fire Standards and are the direct responsibility of Subcommittee E05.15 on Furnishings and Contents.

Current edition approved April 1, 2008; Sept. 1, 2016. Published April 2008; October 2016. Originally approved in 1990. Last previous edition approved in 2008 as E1353—08; E1353 – 08a<sup>ε1</sup>. DOI: 10.1520/E1353-08A.10.1520/E1353-16.

<sup>2</sup> For referenced ASTM standards, visit the ASTM website, [www.astm.org](http://www.astm.org), or contact ASTM Customer Service at [service@astm.org](mailto:service@astm.org). For *Annual Book of ASTM Standards* volume information, refer to the standard's Document Summary page on the ASTM website.

<sup>3</sup> Available from Standardization Documents Order Desk, Bldg. 4 Section D, 700 Robbins Ave., Philadelphia, PA 19111-5094, Attn: NPODS.

\*A Summary of Changes section appears at the end of this standard

### 2.3 NFPA Standard:<sup>4</sup>

**NFPA 260 Standard Methods of Tests and Classification System for Cigarette Ignition Resistance of Components of Upholstered Furniture**

## 3. Terminology

3.1 *Definitions:* For definitions of terms used in these test methods, refer to Terminology **E176**.

3.2 *Definitions of Terms Specific to This Standard:*

3.2.1 *deck*—in upholstered furniture, the upholstered support under the seat cushion in a loose seat construction.

3.2.2 *obvious ignition*—pronounced continuous and self-sustaining combustion of the test system accompanied by rapid generation of heat and smoke. It is a matter of operator judgment based upon experience in this type of operation.

3.2.3 *upholstered*—covered with material (as fabric or padding) to provide a soft surface.

3.2.4 *upholstered furniture*—for the purpose of these test methods, a unit of interior furnishing that (1) contains any surface that is covered, in whole or in part, with a fabric or related upholstery cover material, (2) contains upholstery material, and (3) is intended or promoted for sitting or reclining upon.

3.2.5 *upholstery cover material*—the outermost layer of fabric or related material used to enclose the main support system or upholstery materials, or both, used in the furniture item.

3.2.6 *upholstery material*—the padding, stuffing, or filling material used in a furniture item, which may be either loose or attached, enclosed by an upholstery cover material, or located between the upholstery cover material and support system, if present.

<sup>4</sup> Available from National Fire Protection Association (NFPA), 1 Batterymarch Park, Quincy, MA 02169-7471, <http://www.nfpa.org>.

### 3.2.6.1 Discussion—

This includes, but is not limited to, material such as foams, cotton batting, polyester fiberfill, bonded cellulose, or down.

3.2.7 *welt*—the piping effect produced when welt cord and cover fabrics are sewn together for ornamental purposes to finish the edges between intersecting surfaces of upholstered furniture cushions, pillows, arms, or backs.

3.2.8 *welt cord*—the continuous small-diameter cylindrical material that is wrapped in fabric and sewn as part of the cover to make a welt edge on upholstered furniture.

## 4. Summary of Test Method

4.1 These test methods consist of several tests used to evaluate the cigarette ignition resistance of component materials used in the manufacture of upholstered furniture. Each test involves a miniature assembly consisting of the component to be tested, along with other specified materials, mounted on a plywood mock-up that resembles a small chair seat and back. The assembly is exposed to a lighted cigarette as an ignition source.

## 5. Significance and Use

5.1 These test methods are intended to estimate the performance of upholstered furniture under conditions of exposure to a smoldering cigarette. This is accomplished by testing furniture component assemblies. However, interactions between components in production furniture are not necessarily predicted by component assembly testing.

5.2 These test methods are not intended to measure the performance of upholstered furniture under conditions of open flame exposure, and do not indicate whether the furniture will resist the propagation of flame under severe fire exposure or when tested in a manner that differs substantially from the test standard.

5.3 The results obtained with a material component tested in mock-up, in accordance with these test methods, do not necessarily indicate the performance of the same material component in other geometric configurations, such as in full-size furniture.

## 6. Apparatus and Materials

6.1 *Mini-Mock-Up Tester (MMT)* (see **Fig. 1**):

6.1.1 The mini-mock-up tester consists of a base with a centrally located guide and a stationary vertical panel, a movable horizontal carriage, and a removable vertical support panel.

6.1.2 The base consists of two wooden panels, each nominally 8 by 8 in. with nominal 0.75-in. thickness, joined together at one edge. The carriage has a 5 by 8-in. (125 by 203-mm) platform to support a horizontal specimen. The platform is 2.5 in. (38 mm) above the floor of the base and has a 1.5-in. (38-mm) lip at the front edge. The carriage is grooved to fit over a guide provided on the floor of the base. The removable vertical support panel consists of a wooden panel nominally 8 by 8 in. and with nominal 0.75-in. thickness, which stands against the vertical wall of the base.

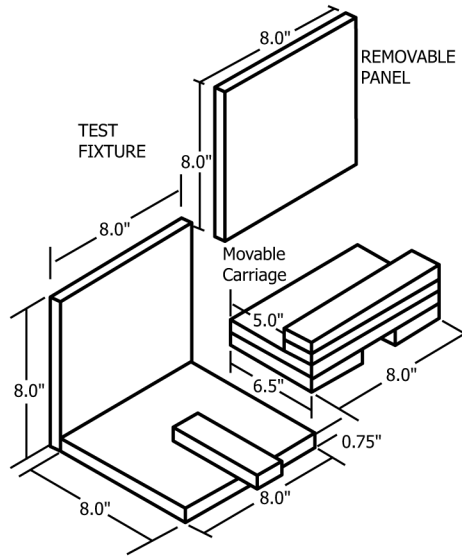

FIG. 1 Mini-Mock-Up Tester

6.2 *Decking Materials Tester (DMT)* (see Fig. 2)—The decking materials tester consists of a plywood base and a plywood retainer ring. The base measures 21 by 13.5 by 0.5 in. (533 by 343 by 13 mm). The retainer ring measures 21 by 13.5 by 0.5 in. with an opening measuring 16 by 8.5 in. (406 by 216 mm).

6.3 *Ignition Source*—The ignition source shall consist of SRM 1196 cigarettes without filter tips, made from natural tobacco,  $3.4 \pm 0.1$  to  $3.3 \pm 0.1$  in. ( $85 \pm 2$  to  $83 \pm 2$  mm) long with a tobacco packing density of  $0.156 \pm 0.012$  ozoz/in.<sup>2-3</sup> ( $0.270 \pm 0.020$  g/cm<sup>2-3</sup>) and a total weight of  $0.039 \pm 0.004$  oz ( $1.1 \pm 0.1$  g). The smoldering rate of this cigarette shall be  $0.236 \pm 0.024$  in./min (0.10 ± 0.01 mm/s) when the cigarette is allowed to burn downward in a draft-protected area, is obtained from the National Institute of Standards and Technology.

NOTE 1—With the cigarette supported at the bottom in a vertical position, the burning rate is determined in the region from 0.39 to 1.97 in. (10 to 50 mm) measured from the top.

6.4 *Standard Type I Cover Fabric*—The standard Type I cover fabric shall be 100 % cotton mattress ticking conforming to Fed. Spec. CCC-C-436-D. It shall be laundered and tumble-dried once before using.

6.5 *Standard Type II Cover Fabric*—The standard Type II cover fabric shall be UFAC standard Type II, 100 % bright regular rayon, scoured, 20/2, ring spun, basketweave construction,  $8.0 \pm 0.5$  oz/yd<sup>2</sup> ( $271 \pm 12$  g/m<sup>2</sup>), undyed, containing no flame-retardant finishes or back coating.

6.6 *Sheeting Material*—The sheeting material to cover the test cigarettes shall be 50 % cotton/50 % polyester or 100 % cotton bed sheeting material weighing  $3.7 \pm 0.8$  oz/yd<sup>2</sup> ( $125 \pm 28$  g/m<sup>2</sup>). The material shall be laundered in an automatic home clothes washing machine and dried in a tumble drier at least once before use. For testing, the sheeting material shall be cut into pieces approximately 5 by 5 in. (12.5 by 12.5 cm).

6.7 *Standard Polyurethane Foam Substrate*—The standard polyurethane foam substrate shall be open-celled polyether-type urethane, containing no inorganic fillers or flame retardants, having a density of 1.3 to 1.6 lb/ft<sup>3</sup> (20 to 25 kg/m<sup>3</sup>).

6.8 *Miscellaneous*—Other apparatus required to carry out the testing are: straight pins, a staple gun, a knife or scissors, tongs, and a linear scale graduated in millimeters and tenths of an inch.

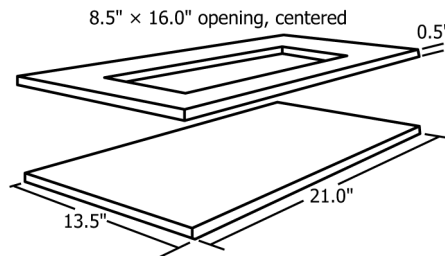

FIG. 2 Decking Materials Tester

6.9 *Air Velocity*—Air velocity across the test assemblies shall be maintained below 50 ft/min (15.2 m/min) in order to minimize localized effects from draft superheating of cigarette embers.

NOTE 1—A fume hood with air curtains across the face and zero air velocity at the test locations is recommended. Zero air velocity is indicated by an undisturbed vertical smoke plume of 6 in.

6.10 *Extinguishing Equipment:*

- 6.10.1 *Pressurized Water Fire Extinguisher*, or other suitable fire extinguishing equipment, immediately available.
- 6.10.2 *Water Bottle*, fitted with a spray nozzle to extinguish any ignited portions of the test specimen.
- 6.10.3 *Bucket of Water*, for immersing smoldering or burning materials removed from the tester.
- 6.10.4 *Tongs*, to handle smoldering materials prior to immersion.
- 6.10.5 *Gloves*.
- 6.10.6 *Breathing apparatus*.

6.11 *Draft-Free Enclosure*—An open draft preventive enclosure shall be provided and used to restrict airflow to convection only (see Fig. 3).

7. Hazards

7.1 **Warning**—Even under the most carefully observed conditions, smoldering combustion can progress to a point where it cannot be readily extinguished. It is imperative that a test be discontinued as soon as continuing combustion has definitely occurred. Immediately wet the exposed area with a water spray from the water bottle, remove the charred or burned material, and immerse the material in a bucket of water. Ventilate the test area.

7.2 Products of combustion can be irritating and dangerous to test personnel. Test personnel must avoid exposure to smoke and gases produced during testing as much as possible. The use of a large hood with a low air velocity during testing is advisable, as a means to remove products of combustion.

8. Conditioning

8.1 Condition all test upholstery fabrics and test materials (including polyurethane, cigarettes, and sheeting material) at a temperature of 70 ± 5°F (21 ± 2.8°C) and less than 65 % relative humidity for at least 24 h prior to testing. If the test room conditions do not meet the specifications above for the conditioning room, then the testing shall be initiated within 10 min after the specimens are removed from the conditioning room.

9. Report

9.1 Report the following information for each component:

- 9.1.1 Test procedure used,
- 9.1.2 Total number of cigarettes applied,
- 9.1.3 Whether ignition occurred,
- 9.1.4 Individual maximum lengths for each specimen, measured to the nearest 0.1 in. (0.2 cm),
  - 9.1.4.1 Measurements exceeding 2 in. (5.1 cm) shall be reported as follows: >2 in.,
- 9.1.5 Whether Class A or Class B, and
- 9.1.6 Test room conditions.

COVER FABRIC TEST

10. Test Specimen

10.1 Cut three specimens, each 8 by 8 in. (203 by 203 mm), from the material to be tested for horizontal panels, and three specimens, 8 by 15 in. (203 by 381 mm), for vertical panels.

10.2 Cut each specimen with its long dimension in the direction of the warp and assembled for testing in a warp-to-warp orientation, such that the major areas of weave variation will lie in the crevice of the assembled test apparatus.

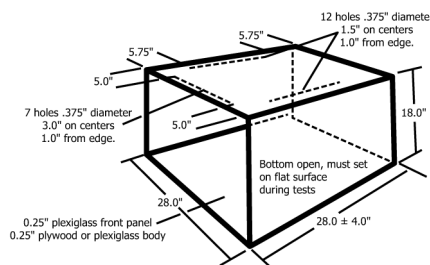

FIG. 3 Draft Enclosure

10.3 For fabrics with complex weaves, cut specimens so that portions of the three largest areas of weave complexity are contacted by the cigarettes placed on the test assemblies. For dyed or printed fabrics, or both, color shall not constitute a difference with respect to cigarette ignition resistance in this test.

**11. Procedure**

11.1 For horizontal panels, place the 8 by 8-in. (203 by 203-mm) cover fabric specimen on an 8 by 5 by 2-in. (203 by 127 by 51-mm) polyurethane substrate as shown in Fig. 4, and pin the ends of the fabric specimens to hold them in place.

11.2 For vertical panels, place the 8 by 15-in. (203 by 381-mm) fabric specimen on an 8 by 8 by 2-in. (203 by 203 by 51-mm) polyurethane substrate as shown in Fig. 4. The fabric shall overlap the top and bottom of the substrate and be pinned into place on the corners. The warp or machine direction of the fabric shall run from front to back on the test assembly.

11.3 Place each assembled vertical and horizontal panel in a mini-mock-up tester as shown in Fig. 4.

11.4 Mark the position of the crevice on the sides of the vertical substrate.

11.5 Light three cigarettes and place a lighted cigarette on each of the three test assemblies so that the cigarette lies in the crevice and against the vertical panel with equal distance of cigarette ends from either side of the assembly.

11.6 Place a piece of sheeting material over each cigarette, smoothing it over the cigarette to ensure intimate contact. Pin the sheeting to the vertical panel about 2.5 in. (63 mm) above the crevice.

NOTE 2—A finger run over the covered cigarettes ensures a good fabric-to-cigarette contact.

11.7 Allow the cigarettes to burn their full lengths unless an obvious ignition of the polyurethane substrate occurs. If a cigarette extinguishes before burning its entire length, place a fresh cigarette on a new test assembly and cover with sheeting fabric until either (1) three cigarettes have burned their entire length on three individual test specimens, or (2) three cigarettes have self-extinguished on the specimen.

11.8 If continuing ignition occurs (that is, fabric and filling materials are ignited and are smoldering and generating smoke at a rapid rate), there is no need to wait until a cigarette has burned its full length. Stop the test and extinguish the burning material. Ventilate the test room and record an ignition for the cigarette test location.

11.9 If no obvious ignition occurs, record the vertical char on the vertical panel, to the nearest 0.1 in. (2.5 mm), measured from the original crevice position to the highest part of the destroyed or degraded fabric. Determine the original crevice position by laying a straightedge or ruler between the two marks previously marked on the edges of the vertical panel. The highest point of destroyed or degraded fabric is defined as the highest point at which any of the fabric is charred from front to back.

11.10 Classify those fabrics that do not develop obvious ignition (see 11.8) and exhibit a vertical char (see 11.9) of less than 1.8 in. (45 mm) as Class I. Classify fabrics developing obvious ignition or vertical char of 1.8 in. or more as Class II.

<https://standards.iteh.ai/catalog/standard/ASTM-E1353-16> INTERIOR FABRIC TEST 8-8aba-753ecc89bb8e/astm-e1353-16

**12. Test Specimen**

12.1 Cut three specimens, each 8 by 8 in. (203 by 203 mm) from the material to be tested.

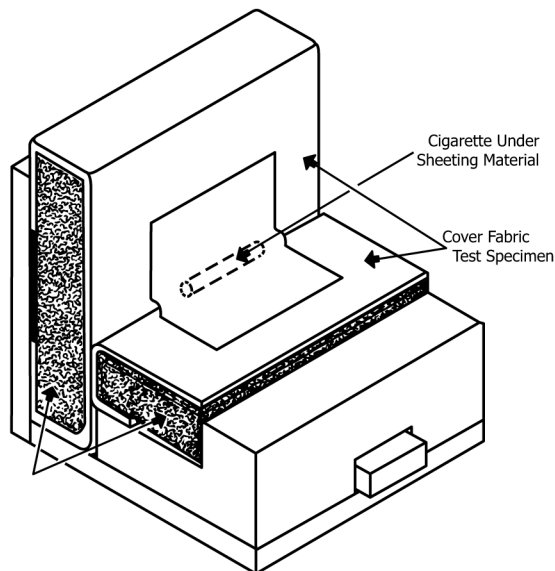

FIG. 4 Cover Fabric Classification Test Method

12.2 Cut three specimens, each 8 by 8 in. (203 by 230 mm), and three specimens, each 12 by 12 in. (305 by 305 mm), from the standard Type I cover fabric.

### 13. Procedure

13.1 For horizontal panels, place the 8 by 8-in. (203 by 203-mm) piece of interior fabric and an 8 by 8-in. piece of standard Type I cover fabric with the interior fabric against the 8 by 5 by 2-in. (203 by 127 by 51-mm) standard polyurethane substrate as shown in Fig. 5, and pin the ends of the fabric specimen to hold it in place.

13.2 For vertical panels, place the 12 by 12-in. (305 by 305-mm) standard Type I cover fabric on an 8 by 8 by 2-in. (203 by 203 by 51-mm) standard polyurethane substrate as shown in Fig. 5. Pull the cover fabric around the edges of the panel and staple to the backside 1 in. (25 mm) from each edge.

13.3 Place each assembled vertical and horizontal panel in a mini-mock-up tester as shown in Fig. 5.

13.4 Mark the position of the crevice on the sides of the vertical polyurethane substrate.

13.5 Light three cigarettes and place a lighted cigarette on each of the three test assemblies so that the cigarette lies in the crevice and against the vertical panel with equal distance of cigarette ends from either side of the assembly.

13.6 Place a piece of sheeting material over each cigarette, smoothing it over the cigarette to ensure intimate contact. Pin the sheeting to the vertical panel about 2.5 in. (63 mm) above the crevice (Note 32).

13.7 Allow the cigarettes to burn their full lengths unless an obvious ignition of the polyurethane substrate occurs. If a cigarette extinguishes before burning its entire length, place a fresh cigarette on a new test assembly and cover with sheeting fabric until either (1) three cigarettes have burned their entire length on three individual test specimens, or (2) three cigarettes have self-extinguished on the specimen.

13.8 If continuing ignition occurs (that is, fabric and filling materials are ignited and are smoldering and generating smoke at a rapid rate), there is no need to wait until a cigarette has burned its full length. Stop the test and extinguish the burning material. Ventilate the test room and record an ignition for the cigarette test location.

13.9 If no obvious ignition occurs, record the vertical char on the vertical panel to the nearest 0.1 in. (25 mm), from the original crevice position to the highest part of the destroyed or degraded interior fabric. Determine the original crevice position by laying a straightedge or ruler between the two marks previously marked on the vertical polyurethane substrate. The highest point of destroyed or degraded fabric is defined as the highest point at which any of the fabric is charred from front to back.

13.10 Classify those fabrics that do not develop obvious ignition (see 13.9) and exhibit a vertical char length (see 13.8) of less than 1.5 in. (38 mm) as Class A. Classify fabrics that develop obvious ignition or exhibit a char length of greater than 1.5 in. (38 mm) as Class B.

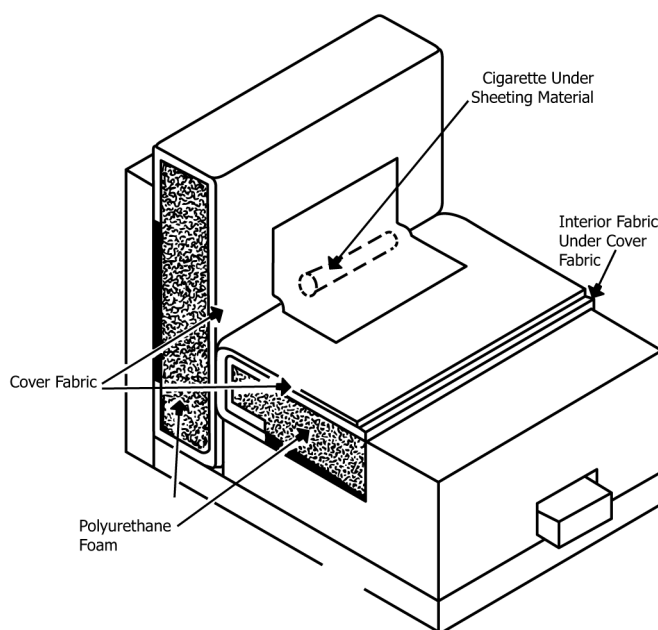

FIG. 5 Interior Fabric Test Method