



Designation: **D6767—14** **D6767 – 16**

Standard Test Method for Pore Size Characteristics of Geotextiles by Capillary Flow Test¹

This standard is issued under the fixed designation D6767; the number immediately following the designation indicates the year of original adoption or, in the case of revision, the year of last revision. A number in parentheses indicates the year of last reapproval. A superscript epsilon (ϵ) indicates an editorial change since the last revision or reapproval.

1. Scope

1.1 This test method covers the determination of the pore size distribution of geotextile filters with pore sizes ranging from 1 to 1000 μm .

NOTE 1—The accuracy of this procedure has been verified up to a maximum pore size of 500 μm . Above this value accuracy has been found to be equipment dependent and should be verified by the user through checks on materials with known opening sizes.

1.2 The test method measures the entire pore size distribution in terms of a surface analysis of specified pore sizes in a geotextile, defined in terms of the limiting diameters.

1.3 The values stated in SI units are to be regarded as standard. No other units of measurement are included in this standard.

1.4 *This standard may involve hazardous materials, operations, and equipment. This standard does not purport to address all of the safety concerns, if any, associated with its use. It is the responsibility of the user of this standard to establish appropriate safety and health practices and determine the applicability of regulatory limitations prior to use.*

2. Referenced Documents

2.1 *ASTM Standards:*²

D1129 Terminology Relating to Water

D1193 Specification for Reagent Water

D4354 Practice for Sampling of Geosynthetics and Rolled Erosion Control Products (RECPs) for Testing

D4439 Terminology for Geosynthetics

3. Terminology

3.1 *Definitions*—For definitions of other terms used in this test method, refer to Terminologies **D4439** and **D1129**.

3.2 *Definitions of Terms Specific to This Standard:*

3.2.1 *bubble point pore size (O_{98}), n* —the largest effective pore diameter detected by the sudden increase of flow rate at the beginning of the wet test.

3.2.2 *pore constriction (O), n* —diameter of a circle having the same area as the smallest section of a given pore.

3.2.3 *pore size (O_i), n* —capillary equivalent pore diameter for which the percent of total pore diameters i in a given geotextile based on the surface occupied by the pores are smaller than or equal to that diameter.

3.2.4 *pore size distribution (PSD), n* —percent cumulative distribution of the complete range of pore sizes with in a given geotextile based on the surface occupied by the pores.

3.2.5 *wetting liquid, fluid, n* —liquid used to wet the geotextile test specimen for the capillary porometry portion of the test method, that is, the “wet” test. The verb “wet” is intended to mean to completely saturate the geotextile specimen with the wetting fluid thoroughly such that the entire thickness of the specimen contains fluid with no entrained air bubbles.

¹ This test method is under the jurisdiction of ASTM Committee **D35** on Geosynthetics and is the direct responsibility of Subcommittee **D35.03** on Permeability and Filtration.

Current edition approved July 1, 2014; Sept. 1, 2016. Published July 2014; October 2016. Originally approved in 2002. Last previous edition approved in 2014 as **D6767D6767 – 14**. DOI: ~~10.1520/D6767-14~~10.1520/D6767-16.

² For referenced ASTM standards, visit the ASTM website, www.astm.org, or contact ASTM Customer Service at service@astm.org. For *Annual Book of ASTM Standards* volume information, refer to the standard’s Document Summary page on the ASTM website.

4. Summary of Test Method

4.1 Geotextile filters have discrete pores from one side to the other of the geotextile. The bubble point test is based on the principle that a wetting liquid is held in these continuous pores by capillary attraction and surface tension, and the minimum pressure required to force liquid from these pores is a function of pore diameter.

4.2 A fluid-wet geotextile will pass air when the applied air pressure exceeds the capillary attraction of the fluid in the pore constriction. Smaller pore constrictions will exhibit similar behavior at higher pressures. The relationship between pore size and pressure has been established for the wetting fluid.

4.3 By comparing the gas flow rates of both a wet and dry test at the same pressures, the percentage of the flow passing through the filter pores larger than or equal to the specified size may be calculated from the pressure-size relationship. By increasing pressure in small steps, it is possible to determine the flow contribution of very small pore size increments by difference.

5. Significance and Use

5.1 This test method may be used to:

- 5.1.1 Determine the pore size distribution of a geotextile,
- 5.1.2 Determine the maximum pore size of a geotextile,
- 5.1.3 Determine the mean flow pore size of a geotextile,
- 5.1.4 Determine the effect of processes such as calendaring or needle punching upon the pore size distribution,
- 5.1.5 Determine the effect of compression upon the pore size distribution of a geotextile, if the test equipment allows,
- 5.1.6 Determine the gas flow rate of a geotextile, and thereby its gas flow capability.

5.2 The pore size distribution test may also be used for research, material development or to assess clogging on field-retrieved samples.

6. Apparatus

6.1 *Clean Gas Pressure Source*, with regulation (filtered air).

6.2 *Pressure Sensor*; pressure measurements may be obtained with a digital pressure transducer, a U-Tube manometer or an inclined manometer covering the necessary pressure range for the pore sizes under study and the wetting fluid used. The pressure sensor sensitivity shall be dictated by the range of pressures associated with the openings sizes. The bubble point pressure should be measured with an accuracy of $\pm 1\%$ or $\pm 5\text{ Pa}$, $\pm 5\text{ Pa}$, whichever is larger.

6.2.1 Pressure sensor(s) must be installed immediately upstream (for example, within 5 mm) of the sample holder.

6.3 *Closed Filter Holder*, (see Fig. 1).

6.3.1 Filter holder for the test specimens that fully confines the perimeter of the specimen to prevent any lateral pressure losses.

6.3.2 The specimen flow area shall be 25-mm diameter. Other diameters shall be verified with comparative tests with the standard 25-mm diameter.

6.3.3 The filter holder should be checked for leaks by placing an impermeable membrane in the holder and increasing the pressure to the maximum capacity of the pressure sensor and holding it for a period of 1 min. The flow rate measured during this period must be “zero.”

6.4 *Metal Punch*, used to cut a suitable size geotextile from the test sheet to fit the test filter holder.

6.5 *Flow Rate Measurement Sensors*, the porometer should be equipped with sensors to measure the flow rate that are high enough to derive the desired pore size distribution. The maximum flow rate measurement required will depend on the opening diameter and the dry air flow that corresponds to the smallest opening that can be determined with this method on the geotextile type under test. The minimum sensitivity, that is, the detection threshold, is dictated by the flow rate that corresponds to the onset of flow at the bubble point. For some geotextiles, this value may be as low as 0.1 L/min.

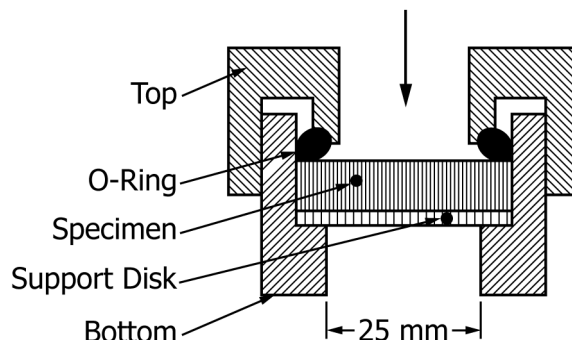

FIG. 1 Closed Filter Holder

6.5.1 A series of floating ball-type flow meters placed in a parallel arrangement to cover the ranges of flow rates is acceptable provided the minimum and maximum flow rate measurements can be obtained with an accuracy of 5 % or less of the measured value.

6.5.2 Digital flow meters are preferred for measurement of flow rates. Two or more digital flow meters of different capacities and sensitivities may be necessary to cover both the minimum detection value and the maximum dry specimen value. The accuracy of digital flow meters shall be 0.25 % of the maximum reading.

6.6 *In-Line Fluid Trap*, for porometers which have the flow rate sensors downstream from the test specimen to protect the flow meters from being contaminated by the exhausted fluid.

6.7 *Appropriate Fittings, Hose, Connectors, Piping*, to assemble apparatus.

6.8 *Balance*, with a precision of 0.001 g.

7. Sampling

7.1 *Lot Sample*—For routine Quality Control testing, divide the product into lots and take the lot sample as directed in Practice **D4354**, Section 7 “Procedure B Sampling for Quality Assurance Testing.” For Specification Conformance testing, sample as directed in Practice **D4354**, Section 6 “Procedure A-Sampling for Specification Conformance.”

7.2 *Laboratory Sample*—As a laboratory sample for acceptance testing, take a full width swatch 1 m long from the end of each roll of fabric in the lot sample, after first discarding a minimum of 1 m of fabric from the very outside of the roll.

7.3 *Test Specimens*—Cut five specimens from each swatch in the laboratory sample with each specimen being cut to fit the appropriate sieve pan. Cut the specimens from a single swatch regularly spaced along a diagonal line on the swatch.

8. Specimen Preparation

8.1 Weigh the specimens previously conditioned at the standard atmosphere for testing geosynthetics to 0.001 g.

8.2 Submerge them in water for 1 h.

8.3 Allow the specimens to air dry at the standard atmosphere for testing geosynthetics. The specimen must be completely dry before testing. Weigh the specimen to 0.001 g after air drying until a constant weight equal to or less than the initial weight of the specimen is achieved. Air may be blown over the specimens with a fan to facilitate drying. Alternatively, condition the specimens 24 h at the standard atmosphere for testing geosynthetics.

9. Wetting Liquids/Fluids

9.1 *Purity of Reagents*—Reagent grade chemicals shall be used for wetting liquids/fluids in all tests. Unless otherwise indicated, it is intended that all reagents shall conform to the specifications of the Committee on Analytical Reagents of the American Chemical Society where such specifications are available.³ Other grades may be used provided it is first ascertained that the reagent is of sufficient high purity to permit its use without lessening the accuracy of the determination.

9.2 *Water*, conforming to Specification **D1193**, Type IV or higher purity.

9.3 *Wetting Fluid*, the standard wetting fluid for this test method is *Mineral Oil*, USP liquid petrolatum heavy, with surface tension of 34.7 dynes/cm at 25°C.

9.3.1 Other wetting fluids may be used as a deviation from the standard. The user shall then verify the consistency of the resulting opening size distribution with the distribution obtained with Mineral Oil using comparative tests.

9.4 *Clean Gas Pressure Source*, with regulation (filtered air).

10. Procedure

10.1 Place a dry geotextile sample disk in the geotextile holder.

10.2 Close the holder and apply gas pressure.

10.2.1 The pressure shall first be increased from zero to a pressure lower to, but close to the pressure associated with the smallest opening. No flow should be detected through the specimen at this stage.

10.2.2 The pressure shall then be increased at a constant rate. The rate at which the pressure is increased can affect the resulting opening distribution. The pressure ramp rate should be slow enough not to produce a “right-shift” of the wet curve, that is, underestimate of the opening size. This should be confirmed with consecutive tests using a single test specimen tested at varying pressure ramp rates. Pressure and flow rate shall be recorded with an acquisition rate sufficient to capture the requisite values.

10.3 Plot the air flow rate versus pressure over the intended range of use.

10.4 Reduce gas pressure and remove the geotextile from the holder.

³ Reagent Chemicals, American Chemical Society Specifications, Am. Chemical Soc., Washington, DC. For suggestions on the testing of reagents not listed by the American Chemical Society, see “Reagent Chemicals and Standards,” by Joseph Rosin, D. Van Nostrand Co., Inc., New York, NY, and the “United States Pharmacopeia.”