



Designation: ~~D3543 – 93 (Reapproved 2008)~~ **D3543 – 93 (Reapproved 2016)**

Standard Test Method for Metal Glide Adhesion¹

This standard is issued under the fixed designation D3543; the number immediately following the designation indicates the year of original adoption or, in the case of revision, the year of last revision. A number in parentheses indicates the year of last reapproval. A superscript epsilon (ϵ) indicates an editorial change since the last revision or reapproval.

1. Scope

1.1 This test method² covers a laboratory procedure for determining damage resulting from metal glide adhesion on floor surfaces.

1.2 The values stated in SI units are to be regarded as the standard.

1.3 *This standard does not purport to address all of the safety concerns, if any, associated with its use. It is the responsibility of the user of this standard to establish appropriate safety and health practices and determine the applicability of regulatory limitations prior to use.* Specific precautions are given in 8.2.

2. Referenced Documents

2.1 *ASTM Standards:*³

[D1436 Test Methods for Application of Emulsion Floor Polishes to Substrates for Testing Purposes](#)

[D3153 Test Method for Recoatability of Water-Emulsion Floor Polishes](#)

3. Significance and Use

3.1 This test method is used to determine the effect of plasticizers in tile on the floor polish itself. If the floor polish is softened by the plasticizers in the tile it will become an adhesive and adhere to the metal glide that is placed on the polish under standard weights at standard temperatures. Various degrees of attack on the polish are evaluated by the damage to the tile underneath the polish.

4. Apparatus

4.1 *Metal Glide Adhesion Tester.*

4.2 *Metal Glides.*^{4,5}

4.3 *Oven*, or other facility, capable of maintaining $37.8 \pm 2.8^\circ\text{C}$ ($100 \pm 5^\circ\text{F}$) and large enough to accommodate the metal glide adhesion tester.

4.4 *Black Official Vinyl Composition Tile*, 304.8 by 304.8 mm (12 by 12 in.).^{6,5}

4.5 *Steel Wool* (00 grade or finer).

5. Description of Metal Glide Adhesion Apparatus⁷

5.1 The test apparatus (Figs. 1-3) consists of three basic parts: a housing frame, a support cover, and nine brass weights and metal glides.

¹ This test method is under the jurisdiction of ASTM Committee D21 on Polishes and is the direct responsibility of Subcommittee D21.04 on Performance Tests. Current edition approved March 1, 2008. Oct. 1, 2016. Published April 2008. October 2016. Originally approved in 1976. Last previous edition approved in 2002 as D3543 – 93 (2008). (2002); DOI: 10.1520/D3543-93R08; 10.1520/D3543-93R16.

² The test method is empirical in that it allows a comparison of the *relative* performance of up to three polishes on the same substrate for each test. It also permits comparison of two polishes with an uncoated portion of the substrate for each test.

³ For referenced ASTM standards, visit the ASTM website, www.astm.org, or contact ASTM Customer Service at service@astm.org. For *Annual Book of ASTM Standards* volume information, refer to the standard's Document Summary page on the ASTM website.

⁴ Metal glides, 0.035-in. cold roll temper 5, nickel plate, 1/8 & -in. base diameter, available from Faultless Caster Corp., Evansville, IN, or their equivalent, have been found satisfactory.

⁵ This is the sole source of supply of the apparatus known to the committee at this time. If you are aware of alternative suppliers, please provide this information to ASTM International Headquarters. Your comments will receive careful consideration at a meeting of the responsible technical committee,¹ which you may attend.

⁶ Available from Chemical Specialties Manufacturers Assoc., 1913 Eye St., N.W. Washington, DC 20006.

⁷ The preferred material for constructing housing frame and support cover is plastic such as poly(methyl methacrylate). However, other materials of construction may be used provided that variables are not introduced due to warping or bending.

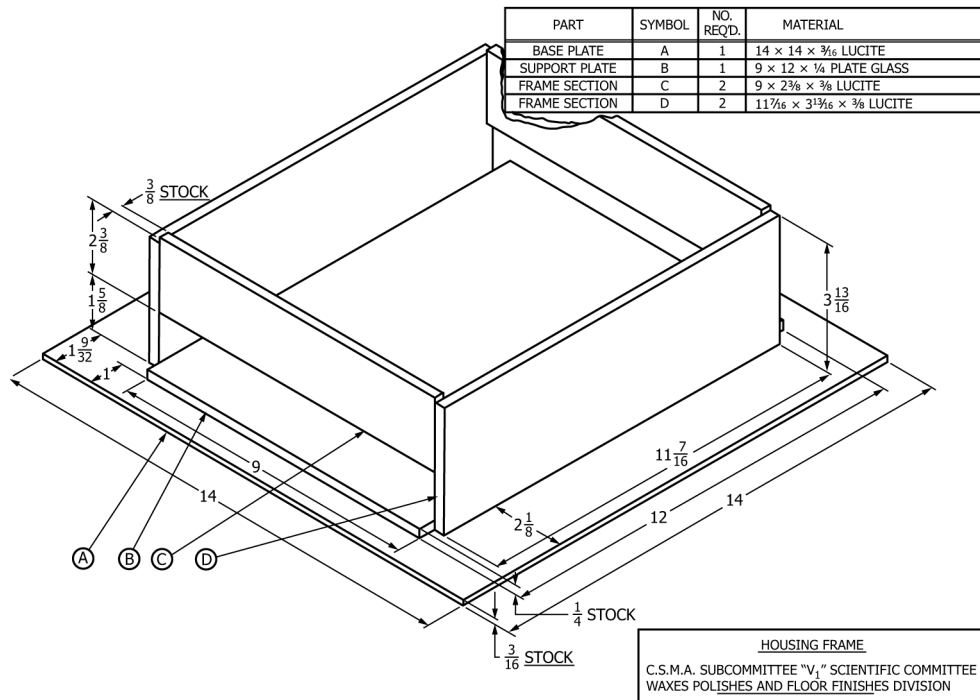

FIG. 1 Housing Frame

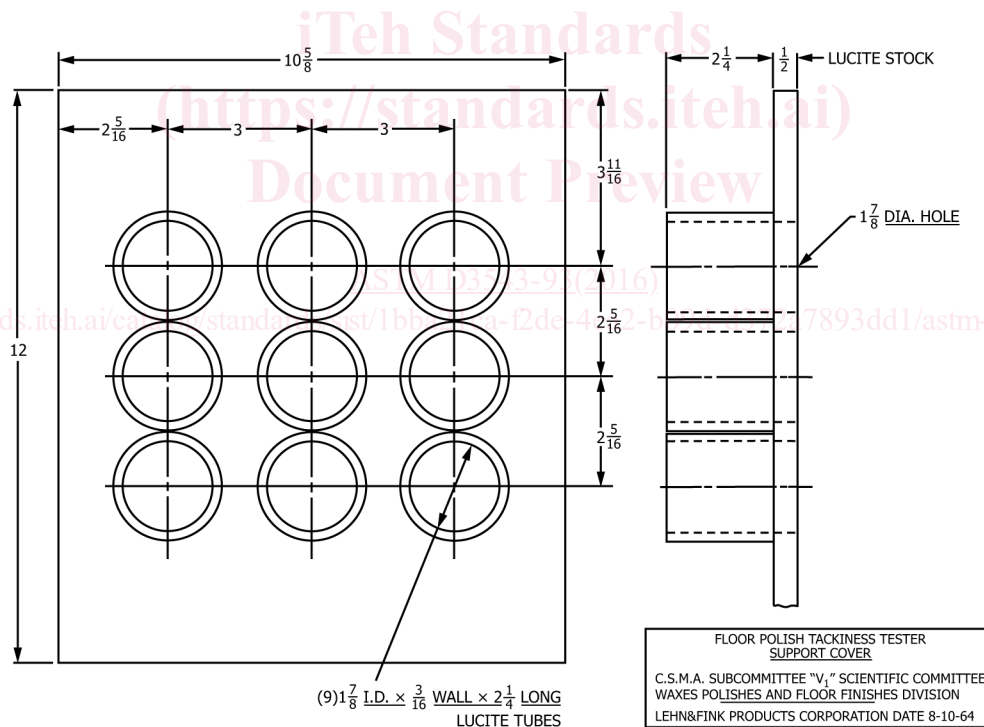

FIG. 2 Support Cover

5.1.1 The housing frame consists of base plate A, frame sections C and D, all made of plastic, and support plate B, made of plate glass (see Fig. 1).

5.1.2 The support cover is constructed of plastic and fits snugly onto the housing frame. The nine tubes allow for supporting and positioning of up to nine brass weights (see Fig. 2).