



## Designation: ~~D4846 – 96 (Reapproved 2011)~~ D4846 – 96 (Reapproved 2016)

# Standard Test Method for Resistance to Unsnapping of Snap Fasteners<sup>1</sup>

This standard is issued under the fixed designation D4846; the number immediately following the designation indicates the year of original adoption or, in the case of revision, the year of last revision. A number in parentheses indicates the year of last reapproval. A superscript epsilon ( $\epsilon$ ) indicates an editorial change since the last revision or reapproval.

## 1. Scope

1.1 This test method covers the determination of the force required to disengage snap fasteners by a pull perpendicular to and parallel with the plane of the snap fastener.

1.2 This test method requires attachment of snaps to specimens using specifications provided by the producers of the snaps.

1.3 This test method is used to establish correlation to wear conditions and for comparing different brands and types of snap fasteners.

1.4 The values stated in SI units are to be regarded as the standard. The values stated in the parentheses are for information only.

1.5 *This standard does not purport to address all of the safety concerns, if any, associated with its use. It is the responsibility of the user of this standard to establish appropriate safety and health practices and determine the applicability of regulatory limitations prior to use.*

## 2. Referenced Documents

2.1 *ASTM Standards:*<sup>2</sup>

[D76 Specification for Tensile Testing Machines for Textiles](#)

[D123 Terminology Relating to Textiles](#)

[D1776 Practice for Conditioning and Testing Textiles](#)

## 3. Definitions

3.1 *lateral holding strength, n*—the force required to disengage a snap fastener resulting from a pull in the plane parallel to the material to which the snap fastener is attached.

3.2 *snap action, n*—the force required to disengage a snap fastener resulting from a pull exerted perpendicular to the plane of material to which the snap fastener is attached.

3.3 *snap fastener, n*—a device for attaching one material to another consisting of matching male and female parts, each of which is attached to a separate material so that the parts can be joined by a low compressive force and separated by a low perpendicular tensile force.

3.4 For definitions of other textile terms used in this test method, refer to Terminology [D123](#).

## 4. Summary of Test Method

4.1 Snap fasteners mounted on strips of material near the end are tested on standard tensile testing machines equipped for testing the strength of textile fabrics and having sensitivity for accurate low force levels.

4.2 Tests are made on snap fasteners before laundering with the option of testing again after a pre-determined number of launderings or other types of refurbishing.

## 5. Significance and Use

5.1 This test method may be used for acceptance testing of commercial shipments of snap fasteners, but caution is advised since information on between laboratory precision is incomplete. Comparative tests as directed in [5.1.1](#) are advisable.

<sup>1</sup> This test method is under the jurisdiction of ASTM Committee [D13](#) on Textiles and is the direct responsibility of Subcommittee [D13.54](#) on Subassemblies. Current edition approved Jan. 1, 2011; Oct. 1, 2016. Published March 2011; October 2016. Originally approved in 1988 as 1988. ~~D4846 – 88~~. Last previous edition approved in 2004/2011 as D4846 – 96 (2011). (2004). DOI: 10.1520/D4846-96R11; 10.1520/D4846-96R16.

<sup>2</sup> For referenced ASTM standards, visit the ASTM website, [www.astm.org](http://www.astm.org), or contact ASTM Customer Service at [service@astm.org](mailto:service@astm.org). For *Annual Book of ASTM Standards* volume information, refer to the standard's Document Summary page on the ASTM website.

5.1.1 In case of a dispute arising from differences in reported test results when using Test Method D4846 for acceptance testing of commercial shipments, the purchaser and seller should conduct comparative tests to determine if there is statistical bias between their laboratories. Competent statistical assistance is recommended for the investigation of bias. As a minimum, the two parties should take a group of test specimens that are as homogeneous as possible and that are from a lot of material of the type in question. The test specimens then should be assigned randomly in equal numbers to each laboratory for testing. The average results from the two laboratories should be compared using Student's *t*-test for unpaired data and an acceptable probability level chosen by the two parties before testing is begun. If a bias is found, either its cause must be found and corrected or the purchaser and seller must agree to interpret future test results in the light of the known bias.

**6. Apparatus**

6.1 *Tensile Testing Machine*—A constant rate of extension (CRE) type or constant rate of traverse (CRT) type testing machine conforming to Specification D76 with a rate of traverse of 305 mm (12 in.)/min, or a rate agreed upon between purchaser and seller, and a scale which will produce accurate results at very low force levels. There may be no overall correlation between the results obtained with the CRE and CRT tensile testing machines. In the case of controversy, however, the CRE method shall prevail.

6.2 *Jaws*—The back jaws of the clamps on the tensile testing machine should be at least the same width as the front jaws. The front jaws must be 25.4 mm (1 in.) wide.

6.3 *Aluminum Plate*—A plate is required measuring 50 by 100 by 4 mm (2 by 4 by 1/8 in.) with dowel pins inserted (see Fig. 1).

6.4 *Attaching Machine*—A hand operated, foot operated, or automatic machine for attaching snap fastener parts conforming to specifications of seller.

**7. Sampling**

7.1 *Lot Sample*—As a lot sample for acceptance testing, take at random the number of shipping cartons of snap fasteners or shipping cartons of garments directed in an applicable material specification or other agreement between the purchaser and the seller. Consider shipping cartons of snap fasteners or shipping cartons of garments to be the primary sampling units.

NOTE 1—An adequate specification or other agreement between the purchaser and the seller requires taking into account the variability between shipping cartons, units within a shipping carton, and between specimens from a unit within a shipping carton, to provide a sampling plan with a meaningful producer's risk, consumer's risk, acceptable quality level, and limiting quality level.

7.2 *Laboratory Sample*—As a laboratory sample for acceptance testing, proceed as follows:

7.2.1 *Unattached Snap Fasteners*—Take one box or card of unattached snap fasteners at random from each shipping carton in the lot sample. If the male and female parts are packed separately, take one box of each from each shipping carton in the lot sample.

7.2.2 *Attached Snap Fasteners*—Take one garment from each shipping carton in the lot sample.

7.3 *Test Specimens:*

7.3.1 *Unattached Snap Fasteners*—From each box or card in the laboratory sample, take five snap fasteners at random. If the male and female parts are packed separately, for each pair of boxes from a shipping carton in the lot sample, take five male parts at random and match them with five female parts taken at random.

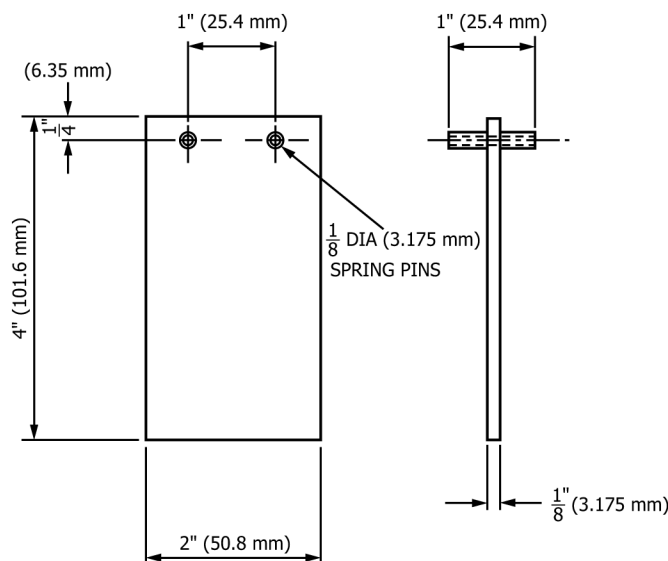

FIG. 1 Aluminum Plate

7.3.2 *Attached Snap Fasteners*—From each garment in the laboratory sample, take five snap fasteners at random on garments with more than five. If less than five, take all snap fasteners from each garment.

## 8. Conditioning

8.1 Condition the specimens by bringing them from the dry side to approximate moisture equilibrium for testing in the standard atmosphere for testing textiles as directed in Practice D1776.

## 9. Procedure

### 9.1 Preparing Specimens:

9.1.1 *Attaching Loose Snap Fasteners*—When snap fasteners are to be attached to a material typical to intended production, the pinch setting and other conditions specified by the seller must be used. Cut fabric specimens to dimensions of 38 by 89 mm (1.5 by 3.5 in.) and attach male part to one fabric specimen and female part to the other fabric specimen, both approximately 19 mm ( $\frac{3}{4}$  in.) from the ends or edge of the fabric specimens (see Fig. 2).

9.1.2 *Cutting Specimens From Garments*—Cut specimen from garments so that the snap fasteners are approximately 19 mm ( $\frac{3}{4}$  in.) from the end of a specimen measuring 38 by 89 mm (1.5 by 3.5 in.). Cut the specimen as close to these dimensions as possible where snap fastener spacings limit specimen size cut from garments.

9.1.3 *Marking of Specimens*—Snap the fastener parts together, keeping the edges of the two pieces of material in alignment. From the center of the snap fastener measure 38 mm (1.5 in.) in each direction and place marks across the two pieces of material to provide a 76 mm (3 in.) overall length and visual reference.

9.2 *Determination of Snap Action*—Set the distance between the upper and lower clamps of the testing machine for 76 mm (3 in.). Clamp the aluminum plate loosely in the jaw of the upper clamp to prevent the specimen from twisting. Insert the female end of the specimen so that the lower edge of the jaw in the upper clamp is even with the mark placed on the material and tighten the clamp. Clamp the male end of the specimen in the jaw of the lower clamp so that the two snapped halves are straight and the pull is perpendicular to the plane of the snap fastener and material (see Fig. 3). Apply the load until the snap fastener disengages. Remove the male end of the specimen from the lower clamp, reset the distance between clamps to 76 mm (3 in.), snap the male specimen to the female specimen, align the pieces so that the fabric material edges are straight and tighten the lower clamp. Apply the load until the snap fastener disengages. Record the nature of the failure and the load at failure to the nearest 0.4 N (0.1 lbf). Repeat this procedure until the specimen has been tested three times.

9.3 *Determination of Lateral Holding Strength*—Use the same specimens prepared from snap action tests. Use the same procedure specified in 9.2 except that the male specimen is clamped in the upper clamp and the force is applied in a plane parallel to the material and snap fastener (see Fig. 4).

## 10. Report

10.1 State that the tests were made as directed in Test Method D4846. Describe the material or product being sampled and the method of sampling used. Describe the material and end product.

10.2 Report the following information:

10.2.1 Type of testing machine and load range used.

10.2.2 Individual and average results.

10.2.3 Note any fabric or snap fastener failure beside results with *F* for fabric and *S* for snap fastener. Disregard fabric failures.

10.3 Report the units of force in newtons (N) or pounds force (lbf).

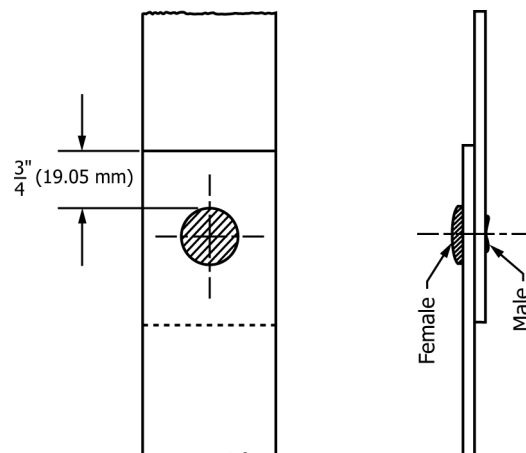

FIG. 2 Specimen and Snap Fastener Arrangement for Testing