



Designation: D5149 – 02 (Reapproved 2016)

Standard Test Method for Ozone in the Atmosphere: Continuous Measurement by Ethylene Chemiluminescence¹

This standard is issued under the fixed designation D5149; the number immediately following the designation indicates the year of original adoption or, in the case of revision, the year of last revision. A number in parentheses indicates the year of last reapproval. A superscript epsilon (ϵ) indicates an editorial change since the last revision or reapproval.

1. Scope

1.1 This test method describes the sampling and continuous analysis of the ozone content of the atmosphere at concentrations of 20 to 2000 μg of ozone/ m^3 (10 ppb (v) to 1 ppm (v)).

1.2 This test method is limited in application by its sensitivity to interferences as described below. This test method is not suitable for personal sampling because of instrument size and sensitivity to vibration and ambient temperature.

1.3 *This standard does not purport to address all of the safety concerns, if any, associated with its use. It is the responsibility of the user of this standard to establish appropriate safety and health practices and determine the applicability of regulatory limitations prior to use.* Some specific precautionary statements are presented in Section 8.

2. Referenced Documents

2.1 *ASTM Standards:*²

[D1356 Terminology Relating to Sampling and Analysis of Atmospheres](#)

[D1357 Practice for Planning the Sampling of the Ambient Atmosphere](#)

[D1914 Practice for Conversion Units and Factors Relating to Sampling and Analysis of Atmospheres](#)

[D3249 Practice for General Ambient Air Analyzer Procedures](#)

[D3670 Guide for Determination of Precision and Bias of Methods of Committee D22](#)

[D5011 Practices for Calibration of Ozone Monitors Using Transfer Standards](#)

[D5110 Practice for Calibration of Ozone Monitors and Certification of Ozone Transfer Standards Using Ultraviolet Photometry](#)

¹ This test method is under the jurisdiction of ASTM Committee D22 on Air Quality and is the direct responsibility of Subcommittee D22.03 on Ambient Atmospheres and Source Emissions.

Current edition approved Oct. 1, 2016. Published October 2016. Originally approved in 1990. Last previous edition approved in 2008 as D5149 – 02 (2008). DOI: 10.1520/D5149-02R16.

² For referenced ASTM standards, visit the ASTM website, www.astm.org, or contact ASTM Customer Service at service@astm.org. For *Annual Book of ASTM Standards* volume information, refer to the standard's Document Summary page on the ASTM website.

[IEEE/ASTM SI-10 Practice for Use of the International System of Units \(SI\) \(the Modernized Metric System\)](#)

2.2 *U.S. Environmental Protection Agency Standards:*³
[EPA-600/4-79-056 Transfer Standards for Calibration of Air Monitoring Analyzers for Ozone \(NTIS: PB80146871\)](#)

[EPA-600/4-79-057 Technical Assistance Document for the Calibration of Ozone Monitors \(NTIS: PB80149552\)](#)

[EPA-600/4-80-050 Evaluation of Ozone Calibration Techniques \(NTIS: PB81118911\)](#)

[EPA-600/4-83-003 Performance Test Results and Comparative Data for Designated Reference and Equivalent Methods for Ozone \(NTIS: PB83166686\)](#)

2.3 *Code of Federal Regulations:*³
[40-CFR-Part 53.20](#)

3. Terminology

3.1 *Definitions*—For definitions of terms used in this test method, refer to Terminology [D1356](#) and Practice [D1914](#). An explanation of units, symbols and conversion factors may be found in Practice [IEEE/ASTM SI-10](#).

3.2 *Definitions of Terms Specific to This Standard:*

3.2.1 *absolute ultra-violet photometer*—a photometer whose design, construction and maintenance is such that it can measure the absorbance caused by ozone mixtures without reference to external absorption standards. Given a value for the absorption coefficient of ozone at 253.7 nm and a reading from the absolute ultraviolet photometer, ozone concentrations can be calculated with accuracy. Measurements by an absolute ultraviolet photometer should be made on prepared ozone mixtures free from interferences.

3.2.2 *primary standard*—a standard directly defined and established by some authority, against which all secondary standards are compared.

3.2.3 *secondary standard*—a standard used as a means of comparison, but checked against a primary standard.

3.2.4 *standard*—an accepted reference sample or device used for establishing measurement of a physical quantity.

³ Available from National Technical Information Service (NTIS), 5285 Port Royal Rd., Springfield, VA 22161, <http://www.ntis.gov>.

3.2.5 *transfer standard*—a type of secondary standard. It is a transportable device or apparatus which, together with operational procedures, is capable of reproducing a sample concentration or producing acceptable assays of sample concentrations.

4. Significance and Use

4.1 Air quality standards for ozone have been promulgated by government authorities to protect the health and welfare of the public. Though ozone itself is a toxic material, it is often complex organic compounds that cause the symptoms of *smog* such as tearing and burning eyes. However, ozone is the predominant oxidant and is much more easily monitored than organic species. Since ozone concentrations are also correlated with other photochemical oxidant levels, it is the substance that is specified in air quality standards and regulations.

5. Interferences

5.1 Any aerosol that scatters light or that may deposit on the photomultiplier window constitutes a negative interference to this test method. Particulate matter can be removed with a poly-tetrafluoroethylene (PTFE) membrane filter; however, this filter may become contaminated and scrub ozone. It is important to check the ozone-inertness of these filters periodically. (See Practice D5110.)

5.2 Atmospheric humidity constitutes a positive interference to this test method when calibrations are conducted with dry span gas mixtures. The range of interference reported is tabulated in Annex A2 of this test method.⁴

5.3 Reduced sulfur compounds have not been found to constitute positive interferences to this test method.⁵

6. Measurement Principle

6.1 This measurement principle is based on the photometric detection of the chemiluminescence (light produced by a chemical reaction) resulting from the flameless gas phase reaction of ethylene (C_2H_4) with ozone (O_3). The sample gas containing ozone is mixed with excess ethylene (bottle gas, C.P. or better, supplied to the instrument) to generate excited formaldehyde ($HCHO^*$) molecules. The excited formaldehyde molecules decay immediately to the ground energy state, releasing energy in the form of light in the 300 to 600 nm region, with maximum intensity at 430 nm. The light energy is measured by a photosensor (frequently a photomultiplier tube) that produces an output current proportional to the light intensity. The current, converted to voltage and conditioned as necessary by the electronic circuits, becomes the analyzer's output signal.

⁴ Kleindienst, T. E., Hudgens, E. E., Smith, D. F., McElroy, F. F., and Bufalini, J. J., "Comparison of Chemiluminescence and Ultraviolet Ozone Monitor Responses in the Presence of Humidity and Photochemical Pollutants," *Journal of the Air and Waste Management Assoc.*, Vol. 43, 1993, p 213.

⁵ Kleindienst, T.C., McIver, C.D., Ollison, W. M., "A Study of Interferences in Ambient Ozone Monitors," VIP-74, *Measurement of Toxic and Related Air Pollutants*, Air & Waste Management Association, Pittsburgh, PA, p. 215.

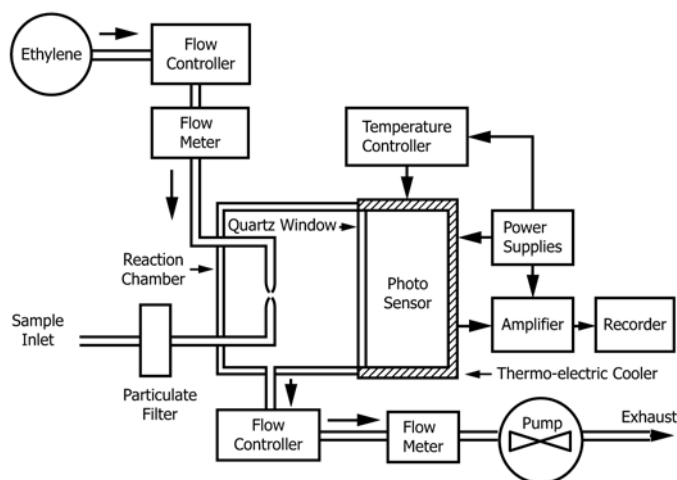

FIG. 1 Schematic Diagram of a Chemiluminescence Ozone Analyzer

7. Apparatus

7.1 A schematic of the instrument is given in Fig. 1. The chemiluminescent reaction cell is constructed of materials inert to ozone, for example, PTFE-coated metal, borosilicate glass, fused silica.

7.2 The input filter is installed in front of the sample line to prevent aerosols or particulate matter from entering the measuring system. PTFE filters with pore sizes between 0.5 and 5.0 μm should be used. The filter should be kept clean since accumulated material on the filter may catalyze the breakdown of ozone into oxygen. Depressed ozone responses have been observed immediately after filter changes for periods up to one hour.

7.3 Internal lines and fittings in the sample stream prior to the reaction cell are made of PTFE or other ozone-inert material.

7.4 Due to the flammability of ethylene, some manufacturers suggest the use of ethylene-carbon dioxide blends instead of 100 % ethylene when the monitoring device is to be used in a public facility. This blend is a liquefied, nonflammable mixture of approximately 9 % ethylene and 91 % CO_2 . The chemiluminescent reaction is the same; however, gas consumption is considerably higher as a result of the reduced ethylene concentration. The proportions of ethylene and CO_2 supplied by the blend change as the mixture is consumed from the cylinder. Since this changes the sensitivity of the analyzer, the analyzer should be recalibrated periodically. The concentration of ethylene supplied by the blend is also changed by the temperature of the cylinder, which must be maintained constant during use.

8. Safety Hazards

8.1 Beyond the normal precautions necessary when working with any instrument that contains high voltages and flammable gases, this test method raises the need for some special considerations. When calibrating the instrument, vent the excess gas mixture, especially if it contains high concentrations