



Designation: **C1479M—13** **C1479M—16**

Standard Practice for Installation of Precast Concrete Sewer, Storm Drain, and Culvert Pipe Using Standard Installations (Metric)¹

This standard is issued under the fixed designation C1479M; the number immediately following the designation indicates the year of original adoption or, in the case of revision, the year of last revision. A number in parentheses indicates the year of last reapproval. A superscript epsilon (ϵ) indicates an editorial change since the last revision or reapproval.

1. Scope

1.1 This practice covers the installation of precast concrete pipe intended to be used for the conveyance of sewage, industrial wastes, and storm water, and for the construction of culverts.

1.2 This practice is the SI companion to Practice **C1479**.

1.3 *This standard does not purport to address all of the safety concerns, if any, associated with its use. It is the responsibility of the user of this standard to establish appropriate safety and health practices and determine the applicability of regulatory limitations prior to use.*

2. Referenced Documents

2.1 ASTM Standards:²

C822 Terminology Relating to Concrete Pipe and Related Products

C1417 Specification for Manufacture of Reinforced Concrete Sewer, Storm Drain, and Culvert Pipe for Direct Design

C1479 Practice for Installation of Precast Concrete Sewer, Storm Drain, and Culvert Pipe Using Standard Installations

D698 Test Methods for Laboratory Compaction Characteristics of Soil Using Standard Effort (12,400 ft-lbf/ft³ (600 kN-m/m³))

D1557 Test Methods for Laboratory Compaction Characteristics of Soil Using Modified Effort (56,000 ft-lbf/ft³ (2,700 kN-m/m³))

D2487 Practice for Classification of Soils for Engineering Purposes (Unified Soil Classification System)

D2488 Practice for Description and Identification of Soils (Visual-Manual Procedure)

IEEE/ASTM SI 10 Standard for Use of the International System of Units (SI): The Modern Metric System

2.2 AASHTO Standards:³

Standard Specifications for Highway Bridges

M 145 Classification of Soils and Soil—Aggregate Mixtures for Highway Construction Purposes

T 99 The Moisture-Density Relations of Soils Using a 5.5-lb (2.5-kg) Rammer and a 12-in. (305-mm) Drop

T 180 The Moisture-Density Relations of Soils Using a 10-lb (4.54-kg) Rammer and an 18-in. (457-mm) Drop

T 310 In-Place Density and Moisture Content of Soil and Soil-Aggregate by Nuclear Methods (Shallow Depth)

2.3 ASCE Standard:⁴

ASCE 15 Standard Practice for the Direct Design of Buried Precast Reinforced Concrete Pipe Using Standard Installations (SIDD)

3. Terminology

3.1 For definitions of terms relating to concrete pipe, see Terminology **C822**.

3.2 For terminology related to soil classifications, see Practices **D2487** and **D2488**.

3.3 For terminology and definitions of terms relating to structural design, see ASCE 15.

¹ This practice is under the jurisdiction of ASTM Committee **C13** on Concrete Pipe and is the direct responsibility of Subcommittee **C13.05** on Special Projects. Current edition approved Feb. 1, 2013/Oct. 15, 2016. Published February 2013/October 2016. Originally approved in 2007. Last previous edition approved in 2012/2013 as **C1479M—12**/**C1479M—13**. DOI: 10.1520/C1479M-13-10.1520/C1479M-16.

² For referenced ASTM standards, visit the ASTM website, www.astm.org, or contact ASTM Customer Service at service@astm.org. For *Annual Book of ASTM Standards* volume information, refer to the standard's Document Summary page on the ASTM website.

³ Available from American Association of State Highway and Transportation Officials (AASHTO), 444 N. Capitol St., NW, Suite 249, Washington, DC 20001, <http://www.transportation.org>.

⁴ Available from American Society of Civil Engineers (ASCE), 1801 Alexander Bell Dr., Reston, VA 20191, <http://www.asce.org>.

3.4 Fig. 1 illustrates the definitions and limits of the terms: foundation, subgrade, bedding, outer bedding, middle bedding, haunch, lower side, backfill or overfill, invert, crown, springline, top of pipe, and bottom of pipe as used in this practice.

4. Significance and Use

4.1 This practice is useful as a reference by an owner and the owner’s engineer in preparing project specifications.

5. Notations

D_i = inside diameter of pipe, mm

D_i = inside diameter of pipe, mm.

D_o = outside diameter of pipe, mm.

H = design height of earth above top of pipe, m.

w = unit weight of soil, N/m³.

D_o = outside diameter of pipe, mm

H = design height of earth above top of pipe, m

w = unit weight of soil, N/m³

6. Standard Installations

6.1 The precast concrete pipe/soil system shall be constructed to conform to the requirements of Figs. 2 and 3 and Tables 1 and 2 as designated on the plans.

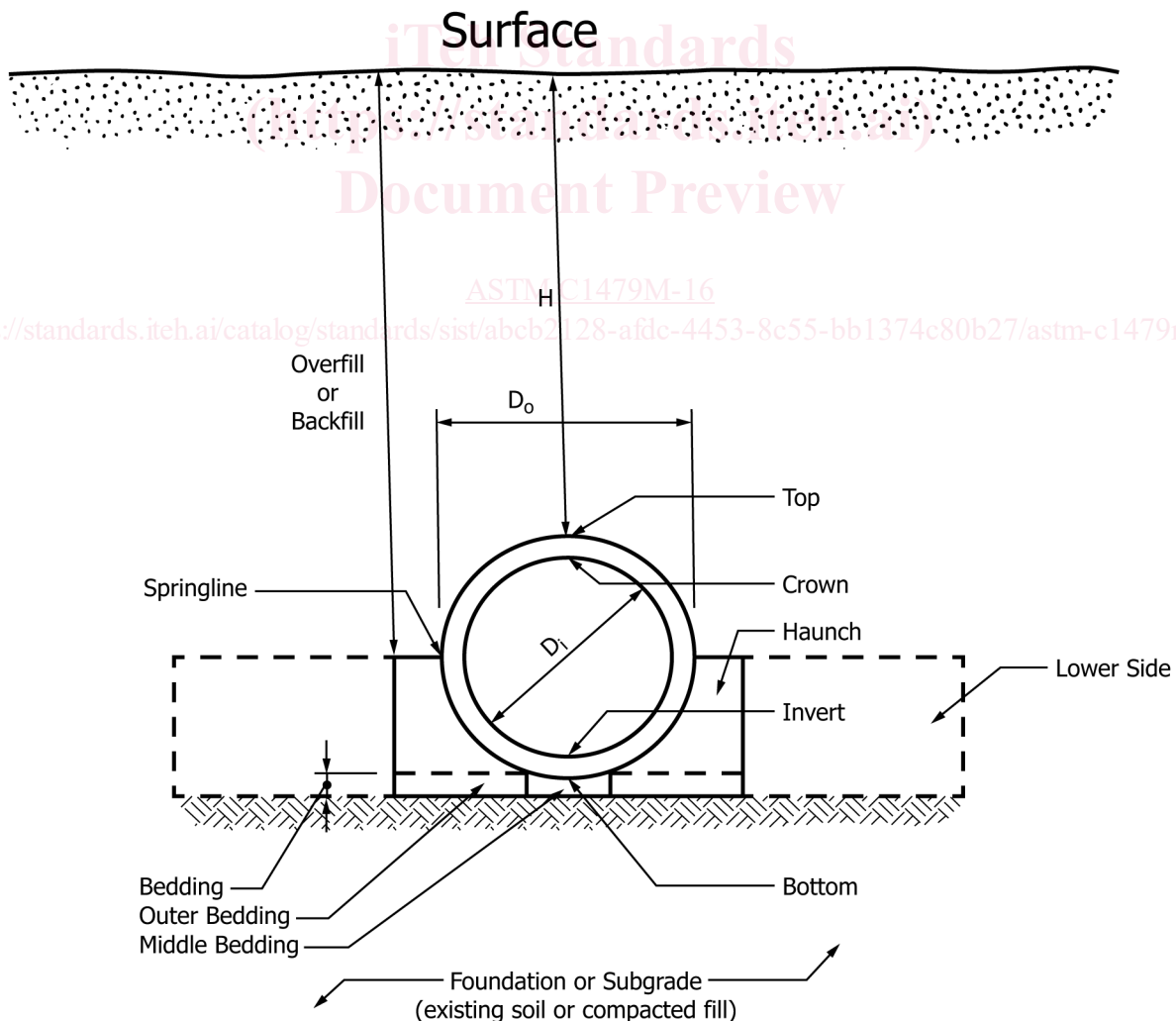

FIG. 1 Pipe/Installation Terminology

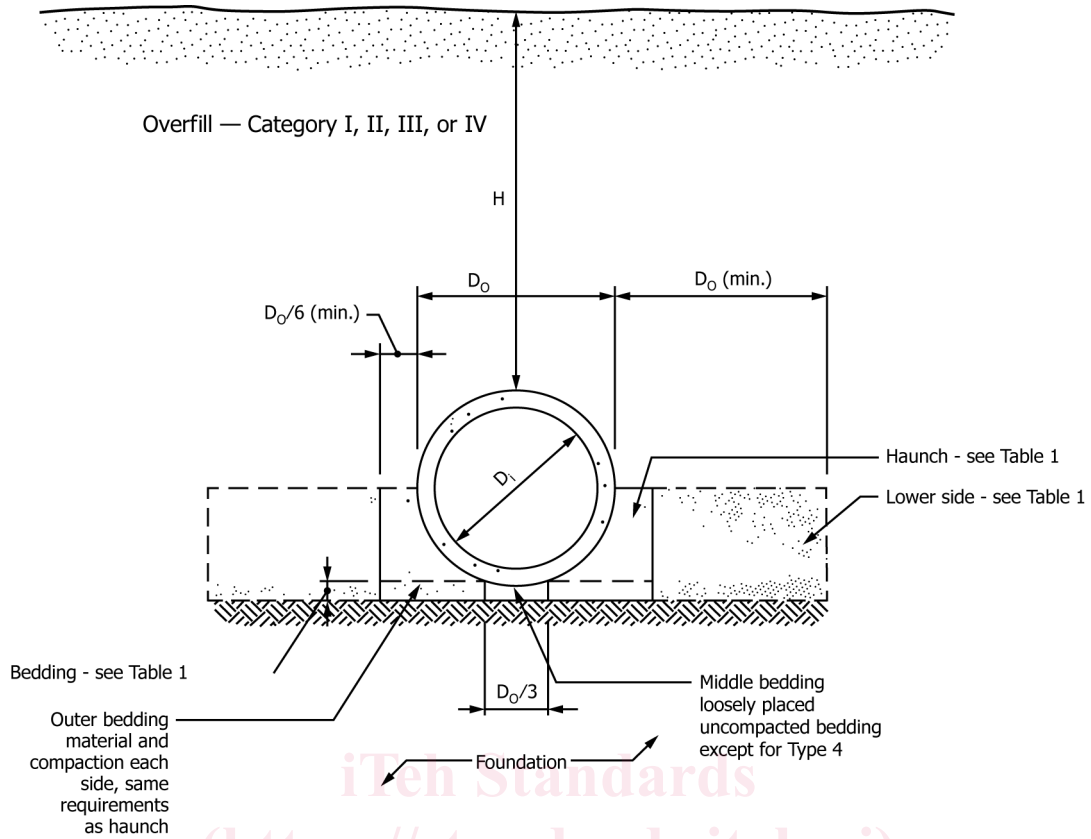
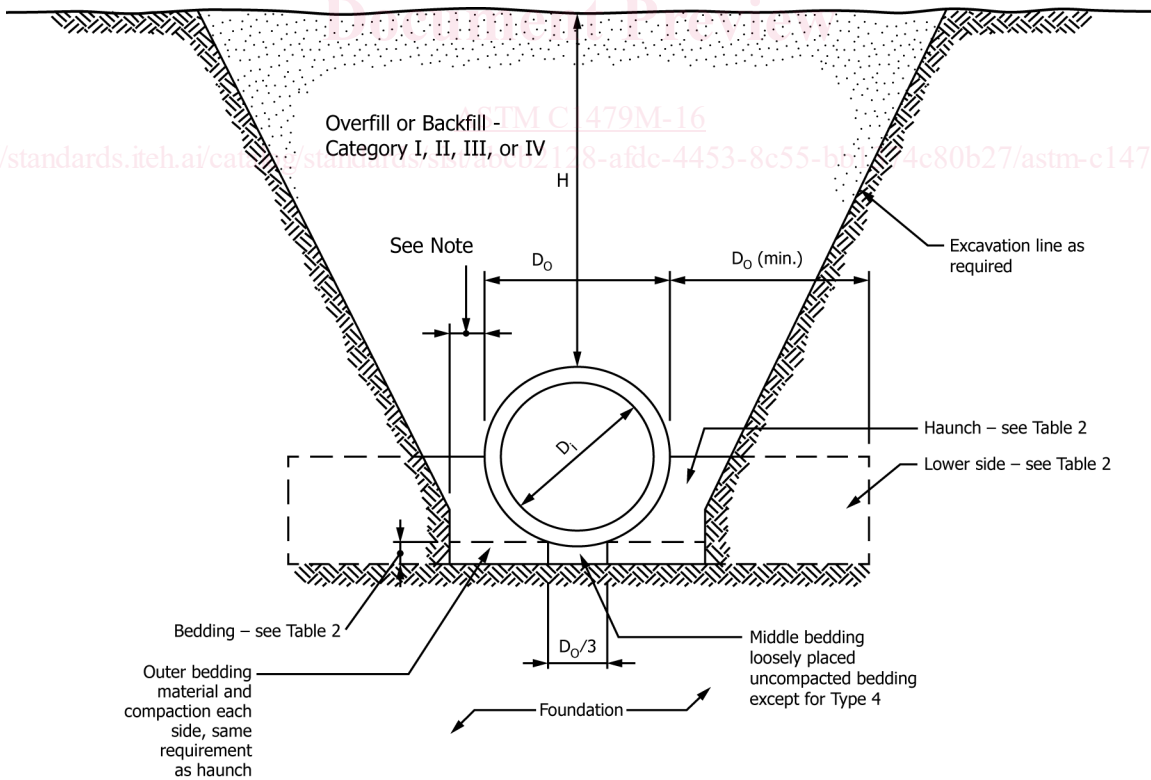

FIG. 2 Standard Embankment Installations



NOTE 1—Clearance between pipe and trench wall shall be adequate to enable specified compaction but not less than $D_0/6$.

FIG. 3 Standard Trench Installations

TABLE 1 Standard Embankment Installation Soils and Minimum Compaction Requirements

NOTE 1—Compaction and soil symbols (that is, 95 % Category I), refer to a soil material category with a minimum standard proctor density. See [Table 3](#) for equivalent modified proctor values and soil types.

NOTE 2—Type 1 installations require greater soil stiffness from the surrounding soils than the Type 2, 3, and 4 installations. Proper field verification of soil properties and compaction levels must be performed to ensure compliance with the design requirements. See [Appendix X2](#) for more information and guidance.

NOTE 3—For Type 1 installation, crushed rock is not an appropriate material for bedding under the pipe. An uncompacted, non-crushed material must be used under the middle third of the pipe outside diameter. While crushed rock meeting the requirements of this specification may self compact vertically, it will not flow laterally to provide support for the haunches of the pipe. To achieve a 90 to 95 % compaction with crushed rock, work material under the haunch and compact it to achieve the specified density. Otherwise, the specified installation is not achieved.

NOTE 4—Soil in the outer bedding, haunch, and lower side zones, except within $D_o/3$ from the pipe springline, shall be compacted to at least the same compaction as the majority of soil in the overfill zone.

NOTE 5—Required bedding thickness is the thickness of the bedding prior to placement of the pipe.

NOTE 6—A subtrench is defined as a trench with its top below finished grade by more than 0.1H or, for roadways, its top is at an elevation lower than 0.3 m below the bottom of the pavement base material.

The minimum width of a subtrench shall be $1.33 D_o$, or wider, if required for adequate space to attain the specified compaction in the haunch and bedding zones.

For subtrenches, except within $D_o/3$ from the springline, any portion of the lower side zone in the subtrench wall shall be at least as firm as an equivalent soil placed to the compaction requirements specified for the lower side zone and as firm as the majority of soil in the overfill zone, or it shall be removed and replaced with soil compacted to the specified level.

NOTE 7—“Dumped” material without additional compactive effort will not provide the design haunch support required for Type 1 and 2 installations.

Installation Type	Bedding Thickness	Haunch and Outer Bedding	Lower Side
Type 1	$D_o/24$ minimum; not less than 75 mm If rock foundation, use $D_o/12$ minimum; not less than 150 mm	95 % Category I	90 % Category I, 95 % Category II
Type 2	$D_o/24$ minimum; not less than 75 mm If rock foundation, use $D_o/12$ minimum; not less than 150 mm	90 % Category I or 95 % Category II	85 % Category I, 90 % Category II, or 95 % Category III
Type 3	$D_o/24$ minimum; not less than 75 mm If rock foundation, use $D_o/12$ minimum; not less than 150 mm	85 % Category I, 90 % Category II, or 95 % Category III	85 % Category I, 90 % Category II, or 95 % Category III
Type 4	No bedding required, except if rock foundation, use $D_o/12$ minimum; not less than 150 mm	No compaction required, except if Category III, use 85 % Category III	No compaction required, except if Category III, use 85 % Category III

7. Excavation

7.1 When rock or other unyielding foundation material is encountered, it shall be removed at least to the requirements shown in [Figs. 2 and 3](#) and [Tables 1 and 2](#). Overexcavated areas shall be backfilled with approved materials and compacted to at least the standard proctor density specified for the bedding.

7.2 Where surface water or groundwater conditions exist, the site and trench shall be dewatered.

8. Foundation

8.1 The foundation shall be moderately firm to hard in situ soil, stabilized soil, or compacted fill material.

8.2 When unsuitable or unstable material is encountered, the foundation shall be stabilized.

8.3 Methods to prevent migration of soil fines shall be provided when groundwater or existing soil conditions are conducive to particle migration. Gravelly soils, with little or no fines, could migrate under certain conditions, causing lack of support.

8.4 Pipe installed over an unyielding foundation shall be cushioned so as to prevent blasting shock when future blasting is anticipated in the area.

TABLE 2 Standard Trench Installation Soils and Minimum Compaction Requirements

NOTE 1—Compaction and soil symbols (that is, 95 % Category I), refer to a soil material category with a minimum standard proctor density. See [Table 3](#) for equivalent modified proctor values and soil types.

NOTE 2—Type 1 installations require greater soil stiffness from the surrounding soils than the Type 2, 3, and 4 installations. Proper field verification of soil properties and compaction levels must be performed to ensure compliance with the design requirements. See [Appendix X2](#) for more information and guidance.

NOTE 3—For Type 1 installation, crushed rock is not an appropriate material for bedding under the pipe. An uncompacted, non-crushed material must be used under the middle third of the pipe outside diameter. While crushed rock meeting the requirements of this specification may self compact vertically, it will not flow laterally to provide support for the haunches of the pipe. To achieve a 90 to 95 % compaction with crushed rock, work material under the haunch and compact it to achieve the specified density. Otherwise, the specified installation is not achieved.

NOTE 4—When the trench width specified must be exceeded, the owner shall be notified.

NOTE 5—The trench width shall be wider than shown ([Fig. 3](#)) if required for adequate space to attain the specified compaction in the haunch and bedding zones.

NOTE 6—Embankment loading shall be used when trench walls consist of embankment unless a geotechnical analysis is made and the soil in the trench walls is compacted to a higher level than the soil in the backfill zone.

NOTE 7—Required bedding thickness is the thickness of the bedding prior to placement of the pipe.

NOTE 8—“Dumped” material without additional compactive effort will not provide the design haunch support required for Type 1 and 2 installations.

Installation Type	Bedding Thickness	Haunch and Outer Bedding	Lower Side
Type 1	D _o /24 minimum; not less than 75 mm If rock foundation, use D _o /12 minimum; not less than 150 mm	95 % Category I	Undisturbed natural soil with firmness equivalent to the following placed soils: 90 % Category I, 95 % Category II, or embankment to the same requirements
Type 2	D _o /24 minimum; not less than 75 mm If rock foundation, use D _o /12 minimum; not less than 150 mm	90 % Category I or 95 % Category II	Undisturbed natural soil with firmness equivalent to the following placed soils: 85 % Category I, 90 % Category II, 95 % Category III, or embankment to the same requirements
Type 3	D _o /24 minimum; not less than 75 mm If rock foundation, use D _o /12 minimum; not less than 150 mm	85 % Category I, 90 % Category II, or 95 % Category III	Undisturbed natural soil with firmness equivalent to the following placed soils: 85 % Category I, 90 % Category II, 95 % Category III, or embankment to the same requirements
Type 4	No bedding required, except if rock foundation, use D _o /12 minimum; not less than 150 mm	No compaction required, except if Category III, use 85 % Category III	No compaction required, except if Category III, use 85 % Category III

9. Bedding

9.1 The bedding shall be constructed uniformly over the full length of the pipe barrel, as required for the designated standard installation, to distribute the load-bearing reaction uniformly on the pipe barrel over its full length, and to maintain the required pipe grade. See [Fig. 4](#). If placed in layers, the thickness of the layers shall be as required to achieve the specified compaction and as required by the project specifications.

9.2 The bedding layers for standard installation Types 1, 2, and 3 shall be placed to be as uniform as possible, but shall be loosely placed uncompacted material under the middle third of the pipe prior to placement of the pipe.

9.3 The maximum aggregate size shall be 25 mm when the bedding thickness is less than 150 mm and 38 mm when the bedding thickness is 150 mm or greater, except as noted in [9.4](#).

TABLE 3 Equivalent USCS and AASHTO Soil Classifications for Soil Designations

Soil	Representative Soil Types		Percent Compaction	
	USCS ASTM Practice D2487	AASHTO M 145	Standard Proctor	Modified Proctor
Category I	Clean, coarse grained soils: SW, SP, GW, GP or any soil beginning with one of these symbols with 12 % or less passing a 75 μm sieve	A-1, A-3	100 95 90 85	95 90 85 80
Category II	Coarse grained soils with fines: GM, GC, SM, SC or any soil beginning with one of these symbols, containing more than 12 % passing a 75 μm sieve Sandy or gravelly fine-grained soils: CL, ML, (or CL-ML, CL/ML, ML/CL) with 30 % or more retained on a 75 μm sieve	A-2-4, A-2-5, A-2-6; or A-4 or A-6 soils with 30 % or more retained on a 75 μm sieve	100 95 90 85	95 90 85 80
Category III	Fine-grained soils: CL, ML, (or CL-ML, CL/ML, ML/CL) with less than 30 % retained on a 75 μm sieve	A-2-7; or A-4 or A-6 with less than 30 % retained on a 75 μm sieve	100 95 90 85	90 85 80 75
Category IV but not allowed for haunch or bedding	MH, CH, OL, OH, PT	A-5, A-7	100 95 90	90 85 80

Compaction Specifications:
 Standard proctor density—AASHTO T 99, T 310, or Test Methods **D698**
 Modified proctor density—AASHTO T 180 or Test Methods **D1557**

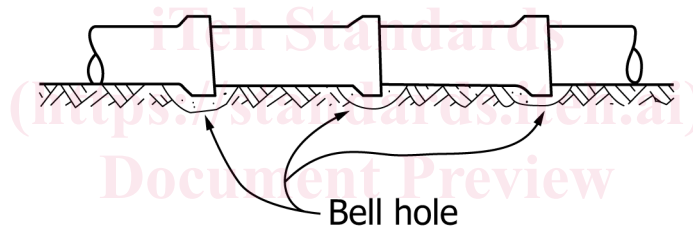

FIG. 4 Uniform Pipe Support

9.4 When *in situ* soils conforming to project specifications are used in constructing the outer bedding for Type 3 and 4 installations, the maximum aggregate size shall not be greater than 75 mm, or half the bedding thickness, whichever is less.

9.5 The use of aggregate sizes larger than 25 mm shall be limited to 20 % of the bedding material by weight.

9.6 Bell holes shall be excavated in the bedding or foundation, or both, when installing pipe with expanded bells so that the pipe is supported by the barrel and not by the bells. See **Fig. 4**.

9.7 Any outer bedding under the lower side areas shall be compacted to at least the same requirements as for the lower side areas.

10. Pipe Placement and Joining

10.1 Pipe shall be installed to the line and grade shown on the project plans and specifications. The joint shall be as specified in the project specifications and shall be installed in accordance with the pipe manufacturer’s recommendations.

NOTE 1—(Advisory) Where practical, work should be started at the lowest end of the pipeline and the pipe laid with the bell end upgrate.

10.2 If required, the top of the pipe section being laid shall be positioned to the correct rotational orientation and then joined.

10.3 The bedding grade under the middle third of the pipe outside diameter shall be prepared before laying the pipe section. Making adjustments in grade by exerting force on the barrel of the pipe with excavating equipment, by lifting and dropping the pipe, or by lifting the pipe and packing bedding material under it shall be prohibited. If the installed pipe section is not on grade, the pipe section shall be completely unjoined, the grade corrected, and the pipe then rejoined.

11. Haunch

11.1 The haunch shall be constructed using the specified soil type and the minimum compaction level required for the designated standard installation. It shall be placed and compacted uniformly for the full length of the pipe barrel so as to distribute the load-bearing reaction uniformly to the bedding over the full length of the pipe barrel. If placed in layers, the thickness of the layers shall be as required to achieve the specified compaction and as required by the project specifications.