



Designation: F2378 – 05 (Reapproved 2016)

# Standard Test Method for Sealability of Sheet, Composite, and Solid Form-in-Place Gasket Materials<sup>1</sup>

This standard is issued under the fixed designation F2378; the number immediately following the designation indicates the year of original adoption or, in the case of revision, the year of last revision. A number in parentheses indicates the year of last reapproval. A superscript epsilon ( $\epsilon$ ) indicates an editorial change since the last revision or reapproval.

## 1. Scope

1.1 This test method covers a means of evaluating the sealing properties of sheet, composite, and solid form-in-place gasket materials (see Classification [F104](#) or [F868](#)) at room temperature, and may be used for fluid (gas or liquid) leak rate measurements. It utilizes relatively short hold times and is not intended to predict long-term performance in application.

1.2 This test method is suitable for evaluating the sealing characteristics of a gasket material under different press loads by measuring the leakage rate. This test method may be used as an acceptance test when the producer and user have agreed to specific test conditions for the following parameters: (1) test medium, (2) internal pressure of the medium, (3) press load on the gasket specimen, and (4) the surface finish of the platens.

1.3 The values stated in SI units are to be regarded as the standard. The values given in parentheses are for information only.

1.4 *This standard does not purport to address all of the safety concerns, if any, associated with its use. It is the responsibility of the user of this standard to establish appropriate safety and health practices and to determine the applicability of regulatory limitations prior to use.*

## 2. Referenced Documents

### 2.1 ASTM Standards:<sup>2</sup>

[D2000 Classification System for Rubber Products in Automotive Applications](#)

[F104 Classification System for Nonmetallic Gasket Materials](#)

[F868 Classification for Laminated Composite Gasket Materials](#)

<sup>1</sup> This test method is under the jurisdiction of ASTM Committee [F03](#) on Gaskets and is the direct responsibility of Subcommittee [F03.10](#) on Composite Gaskets.

Current edition approved Oct. 1, 2016. Published October 2016. Originally approved in 2005. Last previous edition approved in 2011 as F2378 – 05 (2011). DOI: 10.1520/F2378-05R16.

<sup>2</sup> For referenced ASTM standards, visit the ASTM website, [www.astm.org](http://www.astm.org), or contact ASTM Customer Service at [service@astm.org](mailto:service@astm.org). For *Annual Book of ASTM Standards* volume information, refer to the standard's Document Summary page on the ASTM website.

### 2.2 ANSI Standard:<sup>3</sup>

[B57.1 Compressed Gas Cylinder Valve Outlet and Inlet Connections](#)

## 3. Terminology

### 3.1 Definitions:

3.1.1 *press load*—the load applied by the hydraulic press to the test assembly divided by the gasket area. The press load is not compensated for as the internal pressure is increased, so the gasket stress is reduced for the test conditions.

3.1.2 *solid form-in-place gasket*—a solid length of gasketing material generally in a ribbon or rope form that can be laid out on the platen surface and overlapped at the ends to form a continuous sealing surface.

## 4. Summary of Test Method

4.1 This test method utilizes a test specimen compressed in increasing stages between the surfaces of two flat steel platens. After the specified press load is applied, fluid (typically nitrogen) is introduced into the center of the annular gasket compressed between platens, and a pressure of 4 MPa (580 psi) is applied. The fluid leak rate is measured. The fluid pressure is relieved and the press load is increased to the next level. The fluid pressure is reapplied and the leak rate measured again. The cycle is repeated 5 times until a final press load of 32 MPa (4640 psi) is achieved. Other press loads, internal pressures, pressurizing fluids, and number of cycles can be used as agreed upon between the producer and the user. All variations from the standard requirements must be reported with the test results.

4.1.1 The fluid leak rate is measured by mass flow meters located downstream from the gasket test fixture. Other means of leak measurement also may be used and would depend upon the test fluid, the leak rate, and the accuracy required as agreed upon between the producer and the user.

4.2 This test method uses flat platens on which an external load is applied to produce a compressive force on the gasket test specimen. The uncompensated load applied is the press load.

<sup>3</sup> Available from American National Standards Institute (ANSI), 25 W. 43rd St., 4th Floor, New York, NY 10036.

4.3 Results of the sealability tests are typically expressed as a leak rate in mL/min for the test specimen under the specific conditions of the test for gases or mL/h for liquids, or may be expressed as mass loss per unit of time.

**5. Significance and Use**

5.1 This test method is designed to compare sealing characteristics of gasket materials under controlled conditions by providing a precise measure of leakage rate at different press loads up to 32 MPa (4640 psi).

5.2 This test method is suitable for measuring leakage rates from 0.1 mL/min to as high as 5 L/min for gases.

5.3 This test method evaluates leak rates after time periods (typically 30 min) that result in a steady state leakage rate condition. Holding gasket materials under load and internal fluid pressure until steady state is achieved is required to obtain reproducible results.

5.4 If the fluid being used in the test causes changes, such as swelling, in the gasket material, it may affect results and diminish repeatability.

**6. Apparatus**

6.1 The apparatus shall consist of a press frame (for example, one rated at 225 kN (25 tons) or greater), with well-aligned platens, or a ball-jointed platen against a fixed platen. The platens shall be aligned parallel within 2 % of the test specimen nominal thickness.

6.2 *Calibrated Hydraulic System*, or load cells may be used to monitor the load. Hydraulic system should have a load setting and controlling system with an accuracy of ±4 MPa (60 psi) or 1 % of the target load.

6.3 *Calibrated Regulator and Gages*, to monitor internal gas pressure or gas pressure over liquid. Test pressure should be monitored and controlled with an accuracy of ±40 kPa (6 psi).

6.4 *Temperature and Pressure (10.35 MPa (1500 psi)) Corrected Mass Flow Meters*, to monitor gas flow (leakage)

from the gasket fixture. Typically multiple mass flow meters are piped parallel to the flow with only the most sensitive meter for the flow conditions valved to the leakage stream. For example, 0-10, 0-100, and 0-1000 mL/min mass flow meters may all be accurate to 0.25 %, but the former will measure a 1 mL/min-leak 100 times more accurately than the latter. Other leak measurement devices may be used as agreed upon between the producer and the user. Mass flow meters should have an accuracy of ±1 % of full scale or better.

6.5 *Pressure Control Regulators*, to limit variation and alarm, low pressure may be used at the discretion of the users, producers, or both.

6.6 *Platens*, hardened and machined with either a serrated concentric or serrated spiral finish having a resultant surface finish as agreed upon between the producer and user. Platens should be a minimum of 25 mm (1.0 in.) thick. Platens, an example of which is shown in Fig. 1, shall be fitted with an OD rubber seal to contain the leaking gas. The platens shall be suitably drilled to accept the high-pressure gas inlet fitting and to permit a flow of the pressurizing fluid to fill the annulus of the test specimen, and to allow the pressure gage to be connected. The outlet leaking fluid fitting shall be drilled to collect the fluid outside of the test specimen OD and within the rubber seal. The load to seal the rubber seal shall be compensated so that the target press load is achieved within the tolerance of 6.2. The center volume can be fitted with a solid plug to minimize internal volume and aid in platen alignment. The recess in the bottom of the fixture is intended to retain circular alignment with the hydraulic press.

**7. Reagents and Materials**

7.1 Commercially available bottled, compressed nitrogen is the recommended test fluid. Other fluids may be used as agreed upon between the producer and the user.

7.2 Gasket test specimens as agreed upon by the producer and the user.

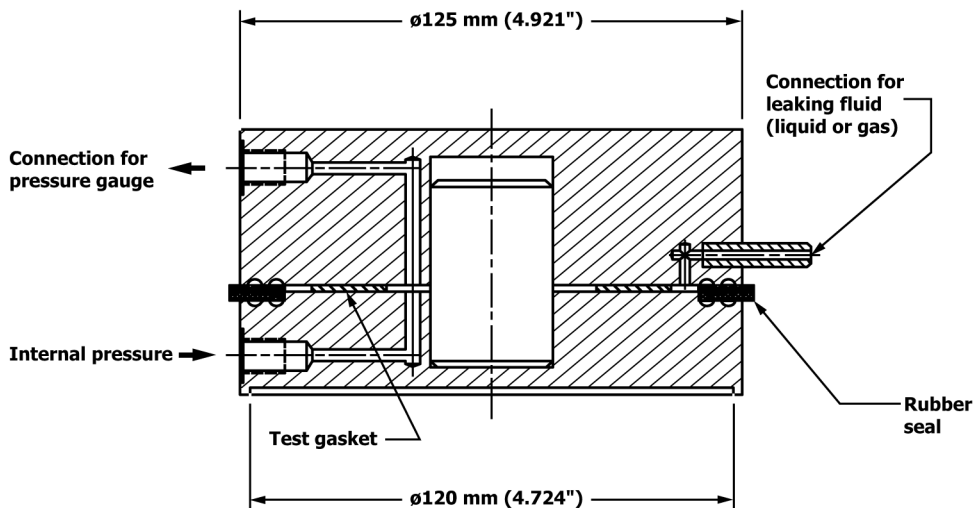

FIG. 1 Test Assembly for Determining Sealability of Gasket Materials

## 8. Hazards

8.1 Normal safety practices required for operating pressure equipment shall be observed by the personnel conducting the tests.

8.2 A suitably mounted, transparent safety shield shall be used as a barrier between the operator and the pressurized system in case of a gasket blowout.

8.3 All components of the system must be designed to safely accommodate a maximum internal working pressure of 10.3 MPa (1500 psi) and a gasket face load of 225 kN (25 tons) in order to satisfy the requirements of the user and ensure the safety of the operator.

8.4 Care shall be exercised to ensure proper support of nitrogen gas cylinders and pressure regulators used for operating pressure control in accordance with ANSI B57.1.

## 9. Sampling, Test Specimens, and Test Units

### 9.1 Preparation of Sheet or Composite Test Specimens:

9.1.1 When sheet or composite gasket materials (see Classification **F104** or **F868**) are to be tested, the test specimens shall be die cut so that the edges are flat, clean, and free from burrs. The size shall be  $50 \pm 0.5$  mm ( $1.968 \pm 0.020$  in.) in inside diameter and  $90 \pm 0.5$  mm ( $3.543 \pm 0.020$  in.) in outside diameter. The thickness shall be 1.5 mm ( $1/16$  in.) nominal or as agreed upon between producer and user. Actual thickness shall be measured and reported. The assumed average area of this test specimen is 4398 mm<sup>2</sup> (6.817 in.<sup>2</sup>).

9.1.2 Test specimens shall be inspected and rejected for surface irregularities, such as scratches, tears, or clumps of fibers.

### 9.2 Preparation of Form-In-Place Test Specimens:

9.2.1 *Types 4 and 5 Form-In-Place Gasket Materials* (see Classification **F104**)—A 245-mm (9.6-in.) piece of standard size material between 4.7 and 6.4 mm ( $3/16$  and  $1/4$  in.) nominal size or width, shall be formed into a circle of 75 mm (3.0 in.) mean diameter. The ends of Type 4 material shall be so laid as to have a  $6.4 \pm 1.6$  mm ( $1/4 \pm 1/16$  in.) overlap to complete the seal. The Type 5 material shall have an overlap of  $1.6 \pm 0.8$  mm ( $1/16 \pm 1/32$  in.) to complete the seal.

9.2.2 Test specimens shall be inspected and rejected for surface irregularities, such as scratches and tears.

## 10. Preparation of Apparatus

### 10.1 Test Method:

10.1.1 Prior to running any tests, check the setup for leaks. This can be accomplished by inserting in the fixture a rubber gasket cut from an approximately 1.0 mm (0.040 in.) thick rubber compound conforming to Grade BG 515 in accordance with Classification **D2000**. Adjust the press load to 32 MPa (4640 psi) and the internal pressure of the test fluid to 4 MPa (580 psi). The system shall be free of leaks for 30 min under these conditions.

## 11. Calibration and Standardization

11.1 The load frame should be calibrated using suitable equipment, for example Morehouse Rings from Morehouse

Instrument Company.<sup>4</sup> Calibration range shall be consistent with the load range needed. Suitable calibration curves shall be generated as needed.

11.2 Gages to monitor internal fluid pressure should be calibrated using suitable equipment, for example, Transmation Precision Pressure Calibrator Model 109.<sup>5</sup> Calibration range shall be consistent with the internal pressure being monitored. Calibration curves shall be generated as needed.

11.3 The mass flow meters used to measure gas leakage rates should be calibrated using suitable equipment, for example, Precision Wet Test Meter.<sup>5</sup> Calibration range shall be consistent with the mass flow leak rate being monitored. Calibration curves shall be generated as needed.

11.4 If liquids are used as the pressuring fluid, the liquid measuring system should be calibrated using suitable equipment, for example, Precision Micro Buret.<sup>5</sup> Calibration range shall be consistent with the liquid flow leak rate being monitored. Calibration curves shall be generated as needed.

## 12. Conditioning

12.1 Condition all types of test specimens as specified in Classification **F104** or **F868** unless otherwise agreed upon between the producer and user.

## 13. Procedure

13.1 The temperature of the test shall be 21 to 30°C (70 to 85°F) unless otherwise specified. Tests at temperatures other than ambient must take note of the many temperature effects on the test media, test fixture, and gasket material under evaluation.

13.2 Measure and record the actual thickness of the gasket test specimens as specified in Classification **F104** or **F868** prior to testing.

13.3 Measure and record the weight of the gasket test specimen to the nearest 0.01 g after conditioning and prior to testing.

### 13.4 Leak Rate:

13.4.1 The leak rate will be measured at the following press loads: 6.9 MPa (1000 psi), 10.4 MPa (1500 psi), 13.8 MPa (2000 psi), 17.2 MPa (2500 psi), and 32.0 MPa (4640 psi) (see **Note 1**) unless other press loads are agreed upon between the producer and the user.

**NOTE 1**—The final press load of 32 MPa is similar to the press load requirements in DIN 3535. This DIN test, however, requires a two-hour hold at pressure and the use of two mil polyester film on both sides of the test specimen.

<sup>4</sup> The sole source of supply of the apparatus known to the committee at this time is Morehouse Instrument Company, 1742 Sixth Avenue, York, PA 17403. If you are aware of alternative suppliers, please provide this information to ASTM International Headquarters. Your comments will receive careful consideration at a meeting of the responsible technical committee,<sup>1</sup> which you may attend.

<sup>5</sup> The sole source of supply of the apparatus known to the committee at this time is Transmation, Inc., 977-T Mt. Read Blvd., P.O. Box 60803, Rochester, NY 14606. If you are aware of alternative suppliers, please provide this information to ASTM International Headquarters. Your comments will receive careful consideration at a meeting of the responsible technical committee,<sup>1</sup> which you may attend.