



Standard Test Method for Performance of Large Open Vat Fryers¹

This standard is issued under the fixed designation F2144; the number immediately following the designation indicates the year of original adoption or, in the case of revision, the year of last revision. A number in parentheses indicates the year of last reapproval. A superscript epsilon (ϵ) indicates an editorial change since the last revision or reapproval.

1. Scope

1.1 This test method covers the energy consumption and cooking performance of large-vat open, deep fat fryers. The food service operator can use this evaluation to select a fryer and understand its energy efficiency and production capacity.

1.2 This test method is applicable to floor model gas and electric fryers with 50 lb (23 kg) and greater fat capacity and an 18-in. and larger vat size.

1.3 The fryer can be evaluated with respect to the following (where applicable):

1.3.1 Energy input rate (10.2),

1.3.2 Preheat energy and time (10.4),

1.3.3 Idle energy rate (10.5),

1.3.4 Pilot energy rate (10.6, if applicable),

1.3.5 French fry cooking energy rate and efficiency (10.9),

1.3.6 French fry production capacity and frying medium temperature recovery time (10.9),

1.4 This test method is not intended to answer all performance criteria in the evaluation and selection of a fryer, such as the significance of a high energy input design on maintenance of temperature within the cooking zone of the fryer.

1.5 The values stated in inch-pound units are to be regarded as standard. The values given in parentheses are mathematical conversions to SI units that are provided for information only and are not considered standard.

1.6 *This standard does not purport to address all of the safety concerns, if any, associated with its use. It is the responsibility of the user of this standard to establish appropriate safety and health practices and determine the applicability of regulatory limitations prior to use.*

2. Referenced Documents

2.1 *ASTM Standards:*²

D3588 Practice for Calculating Heat Value, Compressibility Factor, and Relative Density of Gaseous Fuels 2144-092016

2.2 *ANSI Document:*³

ANSI Z83.11 American National Standard for Gas Food Service Equipment

2.3 *ASHRAE Document:*⁴

ASHRAE Guideline 2—1986 (RA90), Engineering Analysis of Experimental Data

2.4 *Other Standards:*

AOAC 983.23 Fat in Foods: Chloroform-Methanol Extraction Method⁵

3. Terminology

3.1 *Definitions:*

¹ This test method is under the jurisdiction of ASTM Committee F26 on Food Service Equipment and is the direct responsibility of Subcommittee F26.06 on Productivity and Energy Protocol.

Current edition approved Oct. 1, 2009/Oct. 1, 2016. Published November 2009/November 2016. Originally approved in 2001. Last previous edition approved in 2007/2009 as F2144 – 07/F2144 – 09. DOI: 10.1520/F2144-09.10.1520/F2144-09R16.

² For referenced ASTM standards, visit the ASTM website, www.astm.org, or contact ASTM Customer Service at service@astm.org. For *Annual Book of ASTM Standards* volume information, refer to the standard's Document Summary page on the ASTM website.

³ Available from American National Standards Institute (ANSI), 25 W. 43rd St., 4th Floor, New York, NY 10036.

⁴ Available from American Society of Heating, Refrigerating, and Air-Conditioning Engineers, Inc. (ASHRAE), 1791 Tullie Circle, NE, Atlanta, GA 30329.

⁵ Available from AOAC International, 481 North Frederick Ave., Suite 500, Gaithersburg, Maryland 20877-2417, http://www.aoac.org.



3.1.1 *large vat fryer, n*—(hereafter referred to as fryer) an appliance designed for cooking large quantities of fish or chicken, in which oils are placed in the cooking vessel to such a depth that the cooking food is essentially supported by displacement of the cooking fluid rather than by the bottom of the vessel. Often referred to as chicken or fish fryers.

3.1.2 *test method, n*—definitive procedure for the identification, measurement, and evaluation of one or more qualities, characteristics, or properties of a material, product, system, or service that produces a test result.

3.2 *Definitions of Terms Specific to This Standard:*

3.2.1 *cold zone, n*—volume in the fryer below the heating elements or heat exchanger surface designed to remain cooler than the cook zone.

3.2.2 *cook zone, n*—volume of oil in which food is cooked.

3.2.3 *cooking energy, n*—total energy consumed by the fryer as it is used to cook breaded chicken product under heavy- and light-load conditions.

3.2.4 *cooking-energy efficiency, n*—quantity of energy imparted to the chicken during the cooking process expressed as a percentage of the quantity of energy consumed by the fryer during the heavy- and light-load tests.

3.2.5 *cooking energy rate, n*—average rate of energy consumed by the fryer while “cooking” a heavy or light load of chicken.

3.2.6 *energy input rate, n*—peak rate at which a fryer consumes energy (Btu/h (kJ/h) or kW), typically reflected during preheat.

3.2.7 *idle energy rate, n*—average rate of energy consumed (Btu/h (kJ/h) or kW) by the fryer while “holding” or “idling” the frying medium at the thermostat(s) set point.

3.2.8 *pilot energy rate, n*—average rate of energy consumption (Btu/h (kJ/h)) by a fryer’s continuous pilot (if applicable).

3.2.9 *preheat energy, n*—amount of energy consumed (Btu (kJ) or kWh) by the fryer while preheating the frying medium from ambient room temperature to the calibrated thermostat(s) set point.

3.2.10 *preheat rate, n*—average rate (°F/min (°C/min)) at which the frying medium temperature is heated from ambient temperature to the fryer’s calibrated thermostat(s) set point.

3.2.11 *preheat time, n*—time required for the frying medium to preheat from ambient room temperature to the calibrated thermostat(s) set point.

3.2.12 *production capacity, n*—maximum rate (lb/h (kg/h)) at which a fryer can bring the specified food product to a specified “cooked” condition.

3.2.13 *production rate, n*—average rate (lb/h (kg/h)) at which a fryer brings the specified food product to a specified “cooked” condition. Production rate does not necessarily refer to maximum rate (production capacity), but varies with the amount of food being cooked.

3.2.14 *uncertainty, n*—measure of systematic and precision errors in specified instrumentation or measure of repeatability of a reported test result.

4. Summary of Test Method

NOTE 1—All of the fryer tests shall be conducted with the fryer installed under a wall-mounted canopy exhaust ventilation hood that shall operate at an air flow rate based on 300 cfm per linear foot (460 L/s per linear metre) of hood length. Additionally, an energy supply meeting the manufacturer’s specifications shall be provided for the gas or electric fryer under test.

4.1 The fryer under test is connected to the appropriate, metered energy source. The measured energy input rate is determined and checked against the rated input before continuing with testing.

4.2 The frying medium temperature in the cook zone is monitored at a location chosen to represent the average temperature of the frying medium while the fryer is “idled” at 350°F (177°C). Fryer temperature calibration to 350°F (177°C) is achieved at the location representing the average temperature of the frying medium.

4.3 The preheat energy and time and idle energy rate are determined while the fryer is operating with the thermostat(s) set at a calibrated 350°F (177°C). The rate of pilot energy consumption also is determined, when applicable, to the fryer under test.

4.4 Energy consumption and time are monitored while the fryer is used to cook six loads of frozen, ¼-in. (6-mm) shoestring potatoes to a condition of 30 ± 1 % weight loss with the thermostat set at a calibrated 350°F (177°C). Cooking-energy efficiency is determined for heavy-load test conditions. French fry production capacity is based on the heavy-load test.

5. Significance and Use

5.1 The energy input rate test is used to confirm that the fryer under test is operating in accordance with its nameplate rating.

5.2 Fryer temperature calibration is used to ensure that the fryer being tested is operating at the specified temperature. Temperature calibration also can be used to evaluate and calibrate the thermostat control dial.

5.3 Preheat energy and time can be used by food service operators to manage their restaurants’ energy demands, and to estimate the amount of time required for preheating a fryer.

5.4 Idle energy rate and pilot energy rate can be used to estimate energy consumption during non-cooking periods.

5.5 Preheat energy, idle energy rate, pilot energy rate, and heavy- and light-load cooking energy rates can be used to estimate the fryer's energy consumption in an actual food service operation.

5.6 Cooking-energy efficiency is a direct measurement of fryer efficiency at different loading scenarios. This information can be used by food service operators in the selection of fryers, as well as for the management of a restaurant's energy demands.

5.7 Production capacity is used by food service operators to choose a fryer that matches their food output requirements.

6. Apparatus

6.1 *Analytical Balance Scale*, for measuring weights up to 50 lb (23 kg), with a resolution of 0.01 lb (0.004 kg) and an uncertainty of 0.01 lb (0.004 kg).

6.2 *Barometer*, for measuring absolute atmospheric pressure, to be used for adjustment of measured gas volume to standard conditions. Shall have a resolution of 0.2 in. Hg (670 Pa) and an uncertainty of 0.2 in. Hg (670 Pa).

6.3 *Canopy Exhaust Hood*, 4 ft in depth; wall-mounted with the lower edge of the hood 6 ft, 6 in. from the floor; and with the capacity to operate at a nominal exhaust ventilation rate of 300 cfm per linear foot (460 L/s per linear metre) of active hood length. This hood shall extend a minimum of 6 in. (152 mm) past both sides and the front of the cooking appliance and shall not incorporate side curtains or partitions. Makeup air shall be delivered through the face registers and/or from the space.

6.4 *Convection Drying Oven*, with temperature controlled at 215 to 220°F (100 ± 3°C), used to determine moisture content of both the raw and cooked food product.

6.5 *Data Acquisition System*, for measuring energy and temperatures, capable of multiple temperature displays updating at least every 2 s.

6.6 *Fry Baskets*, chrome-plated steel construction, supplied by the manufacturer of the fryer under test. At least four baskets are required to test each fryer according to this protocol.

6.7 *Gas Meter*, for measuring the gas consumption of a fryer, shall be a positive displacement type with a resolution of at least 0.01 ft³ (0.0003 m³) and a maximum uncertainty no greater than 1 % of the measured value for any demand greater than 2.2 ft³/h (0.06 m³/h). If the meter is used for measuring the gas consumed by the pilot lights, it shall have a resolution of at least 0.01 ft³ (0.0003 m³) and a maximum uncertainty no greater than 2 % of the measured value.

6.8 *Pressure Gauge*, for monitoring gas pressure. Shall have a range of 0 to 15 in. H₂O (0 to 3.7 kPa), a resolution of 0.5 in. H₂O (125 Pa), and a maximum uncertainty of 1 % of the measured value.

6.9 *Stop Watch*, with a 1-s resolution.

6.10 *Temperature Sensor*, for measuring natural gas temperature in the range of 50 to 100°F (10 to 38°C) with an uncertainty of ±1°F (±0.56°C).

6.11 *Thermocouple(s)*, Polytetrafluoroethylene-insulated, 24 gauge, type T or type K thermocouples capable of immersion with a range of 50 to 400°F (10 to 204°C) and an uncertainty of ±1°F (±0.56°C).

6.12 *Thermocouple Probe(s)*, “fast response” type T or type K thermocouple probe, 1/16 in. or smaller diameter, with a 3-s response time, capable of immersion with a range of 30 to 250°F (–1 to 121°C) and an uncertainty of ±1°F (±0.56°C).

6.13 *Watt-Hour Meter*, for measuring the electrical energy consumption of a fryer, shall have a resolution of at least 10 Wh and a maximum uncertainty no greater than 1.5 % of the measured value for any demand greater than 100 W. For any demand less than 100 W, the meter shall have a resolution of at least 10 Wh and a maximum uncertainty no greater than 10 %.

7. Reagents and Materials

7.1 *French Fries (Shoestring Potatoes)*—Order a sufficient quantity of French fries to conduct both the French fry cook-time determination test and the heavy- and light-load cooking tests. All cooking tests are to be conducted using 1/4-in. (6-mm) blue ribbon product, par-cooked, frozen, shoestring potatoes. Fat and moisture content of the French fries shall be 6 ± 1 % by weight and 68 ± 2 % by weight, respectively.

7.2 *Frying Medium*—Shall be partially hydrogenated, 100 % pure vegetable oil. New frying medium shall be used for each fryer tested in accordance with this test method. The new frying medium that has been added to the fryer for the first time shall be heated to 350°F (177°C) at least once before any test is conducted.

NOTE 2—Generic partially hydrogenated all vegetable oil (soybean oil) has been shown to be an acceptable product for testing by PG&E.

8. Sampling, Test Units

8.1 *Fryer*—A representative production model shall be selected for performance testing.

9. Preparation of Apparatus

9.1 Install the appliance according to the manufacturer's instructions under a 4-ft (1.2-m) deep canopy exhaust hood mounted against the wall with the lower edge of the hood 6 ft, 6 in. (1.98 m) from the floor. Position the fryer with the front edge of frying medium inset 6 in. (152 mm) from the front edge of the hood at the manufacturer's recommended working height. The length of the exhaust hood and active filter area shall extend a minimum of 6 in. (152 mm) past the vertical plane of both sides of the fryer. In addition, both sides of the fryer shall be a minimum of 3 ft (0.9 m) from any sidewall, side partition, or other operating appliance. A "drip" station positioned next to the fryer is recommended. The exhaust ventilation rate shall be based on 300 cfm per linear foot (460 L/s per linear metre) of hood length. The associated heating or cooling system shall be capable of maintaining an ambient temperature of $75 \pm 5^\circ\text{F}$ ($24 \pm 3^\circ\text{C}$) within the testing environment when the exhaust system is operating.

9.2 Connect the fryer to a calibrated energy test meter. For gas installations, a pressure regulator shall be installed downstream from the meter to maintain a constant pressure of gas for all tests. Both the pressure and temperature of the gas supplied to a fryer, as well as the barometric pressure, shall be recorded during each test so that the measured gas flow can be corrected to standard conditions. For electric installations, a voltage regulator may be required to maintain a constant "nameplate" voltage during tests if the voltage supply is not within $\pm 2.5\%$ of the manufacturer's "nameplate" voltage.

9.3 For a gas fryer, adjust (during maximum energy input) the gas supply pressure downstream from the fryer's pressure regulator to within $\pm 2.5\%$ of the operating manifold pressure specified by the manufacturer. Make adjustments to the fryer following the manufacturer's recommendations for optimizing combustion. Proper combustion may be verified by measuring air-free CO in accordance with ANSI Z83.11.

9.4 For an electric fryer, confirm (while the fryer elements are energized) that the supply voltage is within $\pm 2.5\%$ of the operating voltage specified by the manufacturer. Record the test voltage for each test.

NOTE 3—It is the intent of the testing procedure herein to evaluate the performance of a fryer at its rated gas pressure or electric voltage. If an electric fryer is rated dual voltage (that is, designed to operate at either 208 or 240 V with no change in components), the voltage selected by the manufacturer and/or tester shall be reported. If a fryer is designed to operate at two voltages without a change in the resistance of the heating elements, the performance of the fryer (for example, preheat time) may differ at the two voltages.

9.5 Make fryer ready for use in accordance with the manufacturer's instructions. Clean fryer by "boiling" with the manufacturer's recommended cleaner and water and then rinsing the inside of the fry-pot thoroughly.

9.6 To prepare the fryer for temperature calibration, attach an immersion type thermocouple in the fry pot before beginning any tests. The thermocouple used to calibrate the fryer shall be located within 1 in. (25 mm) of the tip of the thermostat probe. If it is not possible to locate a thermocouple near the thermostat probe, position the thermocouple at the rear of the fry pot, 2 in. (51 mm) below the oil fill line and $\frac{1}{2}$ in. (13 mm) from rear wall of the fry pot.

9.7 Cook zone temperature shall be measured using an immersion type thermocouple in the fry vat before beginning any tests. The thermocouple shall be placed in the center of the fry vat, about 1 in. (25 mm) up from the platform the fry baskets rest on.

NOTE 4—For single-basket or split-vat fryers, the thermocouple may be placed at about $\frac{1}{8}$ in. (3 mm) up from the platform the fry baskets rest on.

9.8 If applicable, cold zone temperature shall be measured using an immersion-type thermocouple placed 0.5 in. (12 mm) above the bottom and 1 in. (25 mm) away from the rear wall of the fry vat. The portion of the rear wall not immersed in oil may be used for thermocouple support.

10. Procedure

10.1 General:

10.1.1 For gas fryers, record the following for each test run:

10.1.1.1 Higher heating value.

10.1.1.2 Standard gas pressure and temperature used to correct measured gas volume to standard conditions.

10.1.1.3 Measured gas temperature.

10.1.1.4 Measured gas pressure.

10.1.1.5 Barometric pressure.

10.1.1.6 Ambient temperature.

10.1.1.7 Energy input rate during or immediately prior to test.

NOTE 5—Using a calorimeter or gas chromatograph in accordance with accepted laboratory procedures is the preferred method for determining the higher heating value of gas supplied to the fryer under test. It is recommended that all testing be performed with gas having a higher heating value of 1000 to 1075 Btu/ft³ (37 300 to 40 100 kJ/m³).

10.1.2 For gas fryers, add electric energy consumption to gas energy for all tests, with the exception of the energy input rate test (10.2).

10.1.3 For electric fryers, record the following for each test run:

10.1.3.1 Voltage while elements are energized.

10.1.3.2 Ambient temperature.

10.1.3.3 Energy input rate during or immediately prior to test run.

10.1.4 For each test run, confirm that the peak input rate is within $\pm 5\%$ of the rated nameplate input. If the difference is greater than 5% , terminate testing and contact the manufacturer. The manufacturer may make appropriate changes or adjustments to the fryer.

10.2 *Energy Input Rate:*

10.2.1 Load fryer with water to the indicated fill line and turn the fryer on with the temperature controls set to the maximum setting possible.

10.2.2 For gas fryers, operate the unit for a period of 15 min, then monitor the time required for the fryer to consume 5 ft^3 (0.14 m^3) of gas. Adjustments to input rate may be made by adjusting gas manifold pressure.

10.2.3 For electric fryers, monitor the energy consumption for 15 min with the controls set to achieve maximum input. If the unit begins cycling during the 15 min interval, record the time and energy consumed for the time from when the unit was first turned on until it begins cycling.

10.2.4 Confirm that the measured input rate or power (Btu/h (kJ/h) for a gas fryer and kW for an electric fryer) is within 5% of the rated nameplate input or power. (It is the intent of the testing procedures herein to evaluate the performance of a fryer at its rated energy input rate.) If the difference is greater than 5% , terminate testing and contact the manufacturer. The manufacturer may make appropriate changes or adjustments to the fryer or supply another fryer for testing.

10.3 *Calibration:*

10.3.1 Ensure that frying medium is loaded to the indicated fryer fill line recommended by the manufacturer. Preheat to 350°F (177°C) and allow the fryer to stabilize for 30 min before beginning temperature calibration.

10.3.2 The frying medium temperature shall be measured by attaching a calibrated immersion type thermocouple in the cook zone as detailed in 9.7. The median temperature recorded over three complete thermostat cycles at this point shall be considered as the average temperature for the frying medium.

10.3.3 Where required, adjust the fryer temperature control(s) to calibrate the fryer at an average frying medium temperature of $350 \pm 5^\circ\text{F}$ ($177 \pm 3^\circ\text{C}$). Record the frying medium temperature over three cycles and average the temperatures over the three cycles to verify that the average measured temperature at the frying medium sensor location is $350 \pm 5^\circ\text{F}$ ($177 \pm 3^\circ\text{C}$).

10.4 *Preheat Energy and Time:*

10.4.1 Ensure that frying medium is loaded to the indicated fryer fill line. Record frying medium temperature and ambient kitchen temperature at the start of the test. Frying medium temperature shall be $75 \pm 5^\circ\text{F}$ ($24 \pm 3^\circ\text{C}$) at the start of the test.

10.4.2 With the fry pot uncovered, turn the fryer on with the temperature controls set to attain a temperature within the frying medium of a calibrated $350 \pm 5^\circ\text{F}$ ($177 \pm 3^\circ\text{C}$).

10.4.3 Begin monitoring energy consumption, time, and temperature as soon as the fryer is turned on. For a gas fryer, the preheat time shall include any delay between the time the unit is turned on and the burners actually ignite. Preheat is judged complete when the temperature at the monitored location reaches 340°F (171°C).

10.5 *Idle Energy Rate:*

10.5.1 Ensure that frying medium is loaded to the indicated fryer fill line.

10.5.2 Preheat to 350°F (177°C) and allow frying medium to stabilize at 350°F (177°C) for at least 30 min after the last thermostat has commenced cycling at the thermostat set point.

10.5.3 Monitor the elapsed time, temperature, and energy consumption of the fryer while it is operated under this “idle” condition for a minimum of 2 h. The fryer shall remain uncovered throughout this idle test.

10.6 *Pilot-Energy Consumption (Gas Models with Standing Pilots):*

10.6.1 Where applicable, set gas valve controlling gas supply to the appliance at the “pilot” position. Otherwise set the temperature controls to the “off” position.

10.6.2 Light and adjust pilots according to manufacturer’s instructions.

10.6.3 Record gas reading, electric energy consumed and time before and after a minimum of 8 h of pilot operation.

10.7 *French Fry Preparation:*

10.7.1 The French fry cooking tests are to be conducted using blue-ribbon product, par-cooked, frozen, 1/4-in. (6-mm) shoestring potatoes. Fat and moisture content of the French fries shall be $6 \pm 1\%$ by weight and $68 \pm 2\%$ by weight respectively. This composition data can be provided by the manufacturer or determined using AOAC 983.23 and the moisture content determination procedure in Annex A2.

10.7.2 Prepare French fries for the cooking test by weighing individual basket loads. For individual load sizes, refer to Table 1. Store each load in a self-sealing plastic freezer bag and place the bags in a freezer (operated at $5 \pm 5^\circ\text{F}$) ($20 \pm 3^\circ\text{C}$) in the proximity of the fryer test area until the temperature of the fries has stabilized at the freezer temperature. Monitor the temperature of the fries by implanting a thermocouple in a fry, and placing the fry into one of the bags, that shall be located in a freezer with the test bags.

NOTE 6—Fries should not be stored in plastics bags for more than three days. It was observed by PG&E that ice develops on the inside of the bags indicating that the fries lose moisture.

TABLE 1 French Fry Load Sizes Based on Nominal Tank Size

Fryer Nominal Tank Size	French Fry Heavy-Load Size
18 × 14	5.00 ± 0.02 lb
18 × 18	5.00 ± 0.02 lb
18 × 20	5.00 ± 0.02 lb
18 × 24	5.00 ± 0.02 lb
20 × 20	6.00 ± 0.02 lb
20 × 24	6.00 ± 0.02 lb
24 × 24	8.00 ± 0.02 lb
34 × 24	9.00 ± 0.02 lb

10.7.3 The number of bags to be prepared for the cooking time determination test (10.9) will vary with the number of trials needed to establish a cooking time that demonstrates a $30 \pm 1\%$ fry weight loss during cooking. The first load of each cooking time determination test will not be averaged in the weight loss calculation. When cooking the six loads of the cooking time determination test, the weight loss may increase with each load cooked. For example, Load Three may have a greater weight loss than Load Two, Load Four may have a greater weight loss than Load Three, etc. If the estimated cooking time does not yield a $30 \pm 1\%$ weight loss averaged over the last five loads of the six-load cooking time determination test, the cooking time shall be adjusted and the six-load cooking time determination test shall be repeated.

NOTE 7—It may take several cooking-time determination tests to establish a cook time that yields a $30 \pm 1\%$ weight loss. For example, it may take 24 or 36 bags (two or three tests) to establish a cooking time for a heavy load. It is better to prepare more fries than to not have enough fries to determine the proper cooking time.

10.7.4 For the cooking-energy efficiency and production-capacity tests, the following number of bags needs to be prepared:

10.7.4.1 *Stir-Up Load*—12 bags, and

10.7.4.2 *Heavy Load*—36 bags.

10.8 Cold-Zone Temperature Stabilization:

NOTE 8—During test method development, it was found that a gradual warming of the cold zone had a significant affect on the cooking time of the fries as well as the energy input to the fryer. As the cold zone temperature increased, less energy was required and the measured energy efficiency would increase. To stabilize the cold zone, thus minimizing the variation in cook time and energy consumption, the procedures in 10.8.2 and 10.8.5 were developed.

10.8.1 Ensure that the frying medium is loaded to the indicated manufacturer’s recommended fill line. Confirm that the frying-medium temperature is $350 \pm 5^\circ\text{F}$ ($177 \pm 3^\circ\text{C}$) as calibrated in 10.3. Allow the fryer to stabilize for 30 min after being turned on.

10.8.2 After the 30-min stabilization, vigorously stir the cold zone with a long spoon or equivalent for $5 \text{ min} \pm 30 \text{ s}$ (see Fig. 1).

NOTE 9—While it was recognized that stirring the cold zone is not practiced in industry, it was included in this procedure because stirring provided a simple way to eliminate the variations in cold zone temperature that caused a significant fluctuation in the measured cooking-energy efficiency. To make the cooking-energy efficiency test repeatable, the cold zone must be at the same temperature when beginning each test. This is accomplished with minimal time and effort through manual stirring followed by conducting one 6-load cold-zone-stabilization procedure.

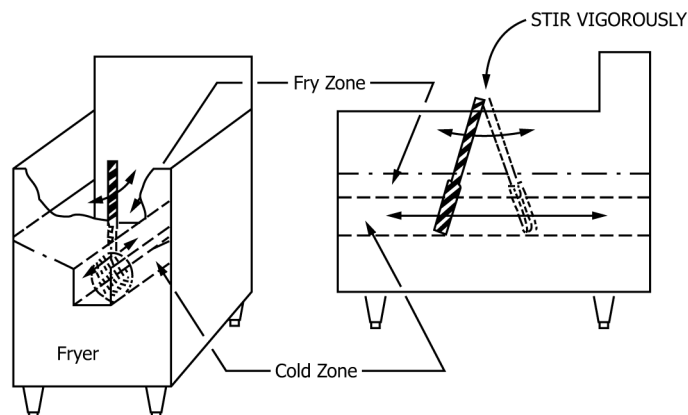
FIG. 1 Stirring of the Cold Zone



10.8.3 All test loads shall be cooked in preconditioned fry baskets held at room temperature ($75 \pm 10^\circ\text{F}$ ($24 \pm 3^\circ\text{C}$)) prior to being loaded with frozen French fries. The fry baskets shall be clean and free of moisture so that they do not contaminate the frying medium. The baskets shall remain at room temperature throughout the cold-zone stabilization, cooking time determination, cooking-energy efficiency, and production capacity tests.

10.8.4 Remove the French fries from the freezer and place directly in the fry baskets. The time from the fries being removed from the freezer until they are lowered into the oil shall not be longer than 30 s. When transferring the fries from the freezer, handle the fries as little as possible. Once the fries are loaded into the baskets, gently shake each basket so that the fries are distributed evenly within the fry basket. Follow this procedure for the cold-zone stabilization tests, cooking time determination tests, cooking-energy efficiency tests, and production capacity tests.

NOTE 10—The 30-s period for the fries to be removed from the freezer (at $55 \pm 5^\circ\text{F}$ ($20(20 \pm 3^\circ\text{C})$) and loaded into the fryer is specified to keep the fries from warming to a temperature of no less than 5°F (-20°C), 5°F (20°C) and no greater than $+5^\circ\text{F}$ (15°C), $(+5^\circ\text{C})$. This ensures that all fries are dropped into the oil at approximately the same temperature ($0 \pm 5^\circ\text{F}$ ($+7(7 \pm 3^\circ\text{C})$)).

10.8.5 After stirring, allow the cold zone to statically stabilize for 3 min \pm 30 s. A sequential six-load stir-up test shall be run immediately to further stabilize the cold-zone temperature. This six-load test shall be a heavy-load test. The cook time shall be estimated for this first six-load, cold-zone stabilization test, but the following sequence shall be followed:

10.8.5.1 After burner(s) or element(s) cycle off, drop the first two baskets of fries into the fryer. Commence monitoring the elapsed time of the cold-zone stabilization test when the first baskets contact the frying medium.

10.8.5.2 Cook the fries for the estimated cook time.

10.8.5.3 Thirty seconds before removing the first load, take the next load out of the freezer and place in baskets ready for cooking.

10.8.5.4 Remove cooked fries to drip station and drain for 2 min.

10.8.5.5 Set the next load of fries into fryer precisely 10 s after removing the previous load from the fryer or after the cook-zone thermocouple indicates that the oil temperature has reached 340°F (171°C), whichever is longer. Repeat the steps in 10.8.5.2 – 10.8.5.5 until all six loads are cooked.

NOTE 11—The 10 s allowed between loads is a preparation time necessary for logistic considerations of running a test (that is, removing one load and placing the next load into the fryer). The actual recovery time may be less than the 10-s preparation time.

NOTE 12—The 2-min drip period must not occur with the fry baskets over the frying medium. Use a drip station or appropriate pan placed beneath the baskets.

10.9 French Fry Cooking Time Determination:

NOTE 13—For precision and logistics, two people are required to perform the cooking-time determination (see 10.9) and the cooking-energy efficiency tests (see 10.10).

10.9.1 Begin the initial cook-time determinations 10 ± 1 min after completing the cold-zone stabilization test. Estimate a cook time for the first heavy- and light-load tests. A separate cook time determination shall be done for each loading scenario. Do not assume the same cook time for heavy and light loads.

10.9.2 Undertake a six-load test for the heavy- and light-load scenarios in the sequence described in 10.8.5. No more than a 10 ± 1 min interval shall elapse between each six-load cooking time determination test. The weight loss shall be an average of the last five loads of each six-load test.

10.9.3 If the average weight loss over the last five loads of the six-load test is not $30 \pm 1\%$, adjust the cook time and repeat the cooking time determination test (all six loads) as necessary, to produce an average $30 \pm 1\%$ weight loss for the five-load average.

NOTE 14—The specified times between each six-load test (10 ± 1 min) are important to maintain the cold zone at its “stabilized” temperature. A stabilized cold zone will reduce the variation in cook times, which ultimately yields a more precise cooking-energy efficiency determination. To keep the cold zone “stabilized” allow no more than 10 ± 1 min to elapse between six-load tests.

10.9.4 Use the cooking times established for heavy- and light-load conditions for the cooking-energy efficiency determination and production capacity tests (10.10).

10.10 Cooking-Energy Efficiency and Production Capacity for Heavy-Load French Fry Tests:

10.10.1 The French fry cooking-energy efficiency and production capacity tests are to be run a minimum of three times. Additional test runs may be necessary to obtain the required precision for the reported test results (see Annex A1). The minimum three test runs for each loading scenario shall be run on the same day.

10.10.2 Prepare the required quantity of French fries making up three replicates of a heavy- and light-load test as described in 10.7.4.

10.10.3 Prepare the required quantity of fries for the six load cold-zone stabilization test as described in 10.7.4.

10.10.4 Prepare an additional 1 lb (454 g) of frozen fries consisting of an apportioned number of fries from multiple bags of frozen French fries, and store in freezer in a glass canning jar (to prevent moisture migration). Reserve these fries for analysis of moisture content.

10.10.5 Load the fryer to the indicated manufacturer’s recommended fill line with the frying medium. Set the thermostat of the fryer to the calibrated frying medium temperature of $350 \pm 5^\circ\text{F}$ ($177 \pm 3^\circ\text{C}$). Allow the fryer to “idle” for 30 min after being turned on.

10.10.6 Use a total of six fry baskets to cook the six loads of fries (also required for the cook-time determination tests). Hold the fry baskets at room temperature ($75 \pm 5^\circ\text{F}$ ($24 \pm 3^\circ\text{C}$)) prior to being loaded with frozen French fries. Also, the fry baskets shall be clean and moisture-free so as not to contaminate the frying medium.

10.10.7 If the cooking-energy efficiency test is done immediately following the cooking-time determination test, no more than 10 ± 1 min shall elapse between the end (the removal of the last basket) of the cooking-time determination test and the beginning of the cooking-energy efficiency test. If the cooking-energy efficiency test is not done immediately following the cooking-time determination test, then the manual stir of the cold zone and a six-load cold-zone stabilization test must be repeated prior to beginning the cooking-energy efficiency test. The manual cold zone stir-up and the cold-zone stabilization test shall be done in accordance with 10.8. Also, no more than 10 ± 1 min must elapse between the removal of the last basket of the six-load stir-up test and the start of the cooking-energy efficiency test.

10.10.8 Cook the fries for the time required to produce a $30 \pm 1\%$ weight loss, determined by averaging the last five loads of each six-load test (10.9). The weight loss for each load is determined after the cooked fries have drained for 2 min following removal from the frying medium.

10.10.9 The cooking-energy efficiency test shall be performed in the following sequence:

10.10.9.1 After the burner(s) or element(s) cycle off, drop the first load into the fryer. The first load of each six-load cooking test shall be used to stabilize the fryer and shall not be counted in the calculation of elapsed time and energy. Commence monitoring cooking energy when the second load contacts the frying medium (the first load may be manually timed).

10.10.9.2 Cook the load of fries for the determined cook time.

10.10.9.3 Thirty seconds before removing the cooking load, take the next load out of the freezer and place in basket(s) conditioned to room temperature ready for cooking (see 10.8.4).

10.10.9.4 Remove cooked fries to drip station and drain for 2 min.

10.10.9.5 Set the next load into the fryer 10 s after removing the first load from the fryer or after the cook zone thermocouple indicates that the oil temperature has recovered to 340°F (171°C), whichever is longer. Repeat 10.10.9.2 – 10.10.9.5 until all six loads have been cooked (Fig. 2).

10.10.10 Terminate the test after removing the last load and either allowing 10 s to pass or waiting for the cook-zone thermocouple to indicate that the oil temperature has recovered to 340°F , whichever is longer (to be consistent with previous loads). Record total elapsed time and consumption of energy for the last five loads of each six-load test.

10.10.11 Reserve 1/4 lb (110 g) of cooked fries (consisting of an apportioned number of fries from each of the five loads) for the determination of moisture content. Unless the moisture content test is conducted immediately, place the fries in a glass canning jar and place the jar in the freezer.

10.10.12 The three loading scenarios shall be run in the following order: three replicates of the heavy load, three replicates of the light load, and three replicates, if applicable, or the extra-heavy load. A 10 ± 1 min interval shall elapse between each test scenario. The overall order of the tests shall be as follows:

10.10.12.1 Perform manual stir and six-load cold-zone stabilization as specified in 10.8.

10.10.12.2 10 ± 1 -min interval wait period,

10.10.12.3 Cook the first replicate of the heavy-load test as specified in 10.10.8 – 10.10.11,

10.10.12.4 10 ± 1 -min interval wait period,

10.10.12.5 Cook the second replicate of the heavy-load test,

10.10.12.6 10 ± 1 -min interval wait period,

10.10.12.7 Cook the third replicate of the heavy-load test.

10.10.13 Replicate each French fry cooking test (three replicates of the heavy- and light-load tests) using the order detailed above, allowing not more than a 10 ± 1 min interval to elapse between replications. The reported cooking-energy efficiency and production capacity for each loading scenario shall be an average of at least three tests (see Annex A1). If the fryer has exhibited high capacity characteristics and it is determined that the fryer can handle the optional extra-heavy load, then proceed with three replicates of the extra-heavy load test.

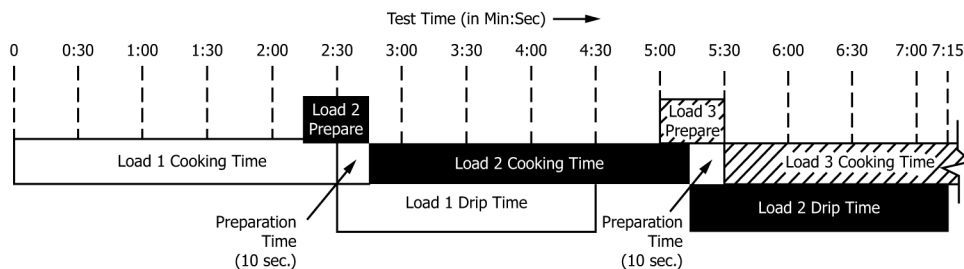

FIG. 2 Sequence of Stir-Up Cook Test (Not to Scale)

10.10.14 If it is not possible to replicate the heavy- and light-load cooking-energy efficiency tests in the manner described in 10.10, a break may occur in the testing at the end of any test as long as the cold zone is restabilized before continuing with the cooking-energy efficiency tests. The restabilization of the cold zone shall be in accordance with all procedures in 10.8. See Fig. 2 for a flowchart of the fry test procedure.

10.10.15 Determine moisture content in accordance with the procedure outlined in Annex A2 and calculate the moisture loss based on initial moisture content of the French fries. Use this value in the cooking-energy efficiency calculation (see 11.9).

11. Calculation and Report

11.1 Test Fryer:

11.1.1 Summarize the physical and operating characteristics of the fryer. If needed, describe other design or operating characteristics that may facilitate interpretation of the test results.

11.1.2 Report fryer vat volume in pounds (lb) according to the manufacturer's recommended fill line.

11.2 Apparatus and Procedure:

11.2.1 Confirm that the testing apparatus conform to all of the specifications in Section 6. Describe any deviations from those specifications.

11.2.2 For electric fryers, report the voltage for each test.

11.2.3 For gas fryers, report the higher heating value of the gas supplied to the fryer during each test.

11.3 Gas Energy Calculations:

11.3.1 For gas fryers, add electric energy consumption to gas energy for all tests, with the exception of the energy input rate test (10.2).

11.3.2 For all gas measurements calculate the energy consumed based on:

$$E_{gas} = V \times HV \quad (1)$$

where:

E_{gas} = energy consumed by the fryer,

HV = higher heating value,

= energy content of gas measured at standard conditions, Btu/ft³ (kJ/m³),

V = actual volume of gas corrected for temperature and pressure at standard conditions, ft³ (m³), and

= $V_{meas} \times T_{cf} \times P_{cf}$

where:

V_{meas} = measured volume of gas, ft³ (m³),

T_{cf} = temperature correction factor,

= absolute standard gas temperature °R (K)/ absolute actual gas temperature °R (K)

= absolute standard gas temperature °R (K)/ [gas temp °F + 459.67] °R (gas temp °C + 273.15)K

P_{cf} = pressure correction factor

= absolute actual gas pressure psia (kPa)/ absolute standard pressure psia (kPa)

= gas gauge pressure psig (kPa) + barometric pressure psia (kPa)/ absolute standard pressure psia (kPa)

NOTE 15—Absolute standard gas temperature and pressure used in this calculation should be the same values used for determining the higher heating value. Standard conditions in accordance with Practice D3588 are 14.696 psia (101.33 kPa) and 60°F (519.67°R (288.71 K)).

11.4 Energy Input Rate:

11.4.1 Report the manufacturer's nameplate energy input rate in Btu/h for a gas fryer and kW for an electric fryer.

11.4.2 For gas or electric fryers, calculate and report the measured energy input rate (Btu/h (kJ/h) or kW) based on the energy consumed by the fryer during the period of peak energy input according to the following relationship:

$$q_{input} = \frac{E \times 60}{t} \quad (2)$$

where:

q_{input} = measured energy input rate, Btu/h (kJ/h) or kW,

E = energy consumed during period of energy input, Btu (kJ) or kWh, and

t = period of energy input, min.

11.5 Fryer Temperature Calibration:

11.5.1 Report the average bulk temperature for the frying medium in the cook zone after calibration. Report any discrepancies between the temperature indicated on the control and the measured average frying medium temperature.

11.6 Preheat Energy and Time:

11.6.1 Report the preheat energy consumption (Btu (kJ) or kWh) and preheat time (min).

11.6.2 Calculate and report the average preheat rate (°F/min (°C/min)) based on the preheat period.

11.7 Idle Energy Rate:

11.7.1 Calculate and report the idle energy rate (Btu/h (kJ/h) or kW) based on:

$$q_{idle} = \frac{E \times 60}{t} \quad (3)$$

where:

q_{idle} = idle energy rate, Btu/h (kJ/h) or kW,
 E = energy consumed during the test period, Btu (kJ) or kWh, and
 t = test period, min.

11.8 Pilot Energy Rate:

11.8.1 Calculate and report the pilot energy rate (Btu/h (kJ/h)) based on:

$$q_{pilot} = \frac{E \times 60}{t} \quad (4)$$

where:

q_{pilot} = pilot energy rate, Btu/h (kJ/h),
 E = energy consumed during the test period, Btu (kJ)
 t = test period, min.

11.9 French Fry Cooking-Energy Efficiency and Cooking Energy Rate:

NOTE 16—The reported French fry cooking-energy efficiency parameters are the average values from the three test replicates.

11.9.1 Calculate and report the cooking energy rate for heavy-load French fry tests based on:

$$q_{fries} = \frac{E \times 60}{t} \quad (5)$$

where:

q_{fries} = cooking energy rate, Btu/h (kJ/h) or kW,
 E = energy consumed during French fry test, Btu (kJ) or kWh, and
 t = cooking test period, min.

11.9.1.1 For gas fryers, report separately a gas French fry cooking energy rate and an electric French fry cooking energy rate.

11.9.2 Calculate and report the energy consumption per pound of fries cooked based on:

$$q_{friesperpound} = \frac{E}{W} \quad (6)$$

where:

$q_{friesperpound}$ = energy per pound, Btu/lb (kJ/kg) or kWh/lb (kWh/kg),
 E = energy consumed during cooking test, Btu (kJ) or kWh, and
 W = total initial weight of the frozen french fries, lb (kg).

11.9.3 Calculate and report the French fry cooking-energy efficiency based on:

$$n_{fries} = \frac{E_{fries}}{E_{fryer}} \times 100 \quad (7)$$

where:

n_{fries} = French fry cooking-energy efficiency, %, and
 E_{fries} = energy into the French fries, Btu (kJ),
 $= E_{sens} + E_{thaw} + E_{evap}$.

where:

E_{sens} = quantity of heat added to the French fries, which causes their temperature to increase from the starting temperature to the average bulk temperature of a done load of French fries (212°F (100°C)), Btu (kJ)
 $= (W_i)(C_p)(T_f - T_i)$

where:

W_i = initial weight of French fries, lb (kg), and
 C_p = specific heat of French fry, Btu/lb, °F (kJ/kg, °C),
 $= 0.695$ (0.898).

NOTE 17—For this analysis, the specific heat (C_p) of a load of French fries is considered to be the weighted average of the specific heat of its components (for example, water, fat, and nonfat protein). Research conducted by PG&E determined that the weighted average of the specific heat for frozen French fries cooked in accordance with this test method was approximately 0.695 Btu/lb, °F (0.898 kJ/kg, °C).