



Designation: **D4644 – 08 D4644 – 16**

## Standard Test Method for Slake Durability of Shales and Other Similar Weak Rocks<sup>1</sup>

This standard is issued under the fixed designation D4644; the number immediately following the designation indicates the year of original adoption or, in the case of revision, the year of last revision. A number in parentheses indicates the year of last reappraisal. A superscript epsilon ( $\epsilon$ ) indicates an editorial change since the last revision or reappraisal.

### 1. Scope\*

1.1 This test method covers the determination of the slake durability index of a shale or other ~~similar weak~~ rock after ~~two~~ three drying and two wetting cycles with ~~abrasion~~ abrasion effects.

1.2 Units—The values stated in SI units are to be regarded as standard. The values given in parentheses are mathematical conversions to inch-pound units, which are provided for information only and are not considered standard. Reporting of test results in units other than SI shall not be regarded as nonconformance with this test method.

1.3 All observed and calculated values shall conform to the guidelines for significant digits and rounding established in Practice D6026.

1.3.1 ~~The method procedures used to specify how data are collected, calculated, collected/recorded or re-recorded calculated in this standard is not directly related to the accuracy to which the data can be applied in design or other uses, or both. How one applies the results obtained using this standard is beyond its scope, are regarded as the industry standard. In addition, they are representative of the significant digits that generally should be retained. The procedures used do not consider material variation, purpose for obtaining the data, special purpose studies, or any considerations for the user's objectives; and it is common practice to increase or reduce significant digits of reported data to be commensurate with these considerations. It is beyond the scope of this standard to consider significant digits used in analysis methods for engineering design.~~

~~1.3 The values stated in SI units are to be regarded as standard. The values given in parentheses are mathematical conversions to inch-pound units that are provided for information only and are not considered standard.~~

1.4 *This standard does not purport to address all of the safety concerns, if any, associated with its use. It is the responsibility of the user of this standard to establish appropriate safety and health practices and determine the applicability of regulatory limitations prior to use.*

### 2. Referenced Documents

- 2.1 *ASTM Standards:*<sup>2</sup>
- [D653 Terminology Relating to Soil, Rock, and Contained Fluids](#)
  - [D2113 Practice for Rock Core Drilling and Sampling of Rock for Site Exploration](#)
  - [D2216 Test Methods for Laboratory Determination of Water \(Moisture\) Content of Soil and Rock by Mass](#)
  - [D3740 Practice for Minimum Requirements for Agencies Engaged in Testing and/or Inspection of Soil and Rock as Used in Engineering Design and Construction](#)
  - [D4753 Guide for Evaluating, Selecting, and Specifying Balances and Standard Masses for Use in Soil, Rock, and Construction Materials Testing](#)
  - [D5079 Practices for Preserving and Transporting Rock Core Samples](#)
  - [D6026 Practice for Using Significant Digits in Geotechnical Data](#)
  - [E11 Specification for Woven Wire Test Sieve Cloth and Test Sieves](#)

### 3. Terminology

3.1 For terminology used in this test method, refer to Terminology ~~D653~~ Definitions:

3.1.1 For terminology used in this test method, refer to Terminology D653.

<sup>1</sup> This test method is under the jurisdiction of ASTM Committee D18 on Soil and Rock and is the direct responsibility of Subcommittee D18.12 on Rock Mechanics. Current edition approved July 1, 2008; Nov. 1, 2016. Published July 2008; November 2016. Originally approved in 1987. Last previous edition approved in 2004 as ~~D4644 – 04~~ D4644 – 08. DOI: ~~10.1520/D4644-08~~ 10.1520/D4644-16.

<sup>2</sup> For referenced ASTM standards, visit the ASTM website, [www.astm.org](http://www.astm.org), or contact ASTM Customer Service at [service@astm.org](mailto:service@astm.org). For Annual Book of ASTM Standards volume information, refer to the standard's Document Summary page on the ASTM website.

\*A Summary of Changes section appears at the end of this standard

3.2 Definitions of Terms Specific to This Standard:

3.2.1 *slake durability index*—the percentage by dry mass of a collection of shale or similar rock pieces retained on a 2.00 mm (No. 10) sieve after ~~two~~<sup>three</sup> cycles of oven drying and two cycles of each 10 min of soaking in distilled water with~~in~~ a standard tumbling and abrasion action.

4. Summary of Test Method

4.1 This test method consists of placing ten pieces of specimens each with mass of 40-60 g in a wire mesh drum mounted in an apparatus where the drum is partially submerged in a trough filled with distilled water. The specimens in the drum are rotated in the water for two cycles. Each cycle includes rotation with speed of 20 rpm for 10 minutes. At the end of first cycle the specimen is oven dried and the total mass of specimen retained in the drum is recorded. Then, a second cycle with the same speed and time period as the first one is performed. The retained total mass of specimen from the second cycle is recorded. The slake durability index is calculated based on both recorded total masses of test specimen retained in the drum per each cycle.

5. Significance and Use

5.1 The test method is used to estimate qualitatively the durability of weak rocks through weakening and disintegration resulting from a standard two cycles of wetting and drying in the service environment. **(1-7)**.<sup>3</sup>

5.2 This test method is used to assign quantitative durability index values to weak rocks. A primary example is the Franklin Rating System **(1)**.

NOTE 1—The quality of the result produced by this standard is dependent on the competence of the personnel performing it, and the suitability of the equipment and facilities used. Agencies that meet the criteria of Practice D3740 are generally considered capable of competent and objective testing, sampling, inspection, and so forth. Users of this standard are cautioned that compliance with Practice D3740 does not in itself assure reliable results. Reliable results depend on many factors; Practice D3740 provides a means of evaluating some of those factors.

6. Apparatus

6.1 *Slake Durability Device*—The drum (Fig. 1) shall be made of 2.00 mm (No. 10) square-mesh, woven-wire cloth, conforming to the requirements of Specification E11. It shall be cylindrical in shape, with a diameter of 140 mm (5.5 in.) and a length of 100 mm (3.9 in.). The ends shall be rigid plates, with one removable end. It must be sufficiently strong to retain its shape during use, but neither the exterior of the mesh nor the interior of the drum shall be obstructed by a support. The drum shall be able to withstand a temperature of 110 ± 5°C (230 ± 9°F). A trough shall support the drum in a horizontal manner such that the drum is partially submerged and free to rotate about its axis. The trough shall be capable of being filled with ~~slaking fluid~~ distilled water to 20 mm (0.8 in.) below the drum axis, and shall allow at least 40 mm (1.6 in.) unobstructed clearance between bottom of the trough and the bottom of the mesh. The drum shall be rotated by a motor capable of maintaining a speed of 20 rpm, constant to within 5 %, for a period of 10 min. ~~Devices conforming to these requirements are commercially available.~~

NOTE 2—Devices conforming to these requirements are commercially available.

6.2 *Drying Oven*, thermostatically controlled, capable of maintaining a temperature of 110 ± 5°C (230 ± 9°F).

6.3 *Balance*, sensitive to ~~with sensitivity of 1 g and having a 2000-g capacity.~~ 3000-g capacity, using the guidelines of Guide D4753.

6.4 *Miscellaneous Apparatus*, including a brush and hammer.

<sup>3</sup> The boldface numbers in parentheses refer to the list of references at the end of this standard.

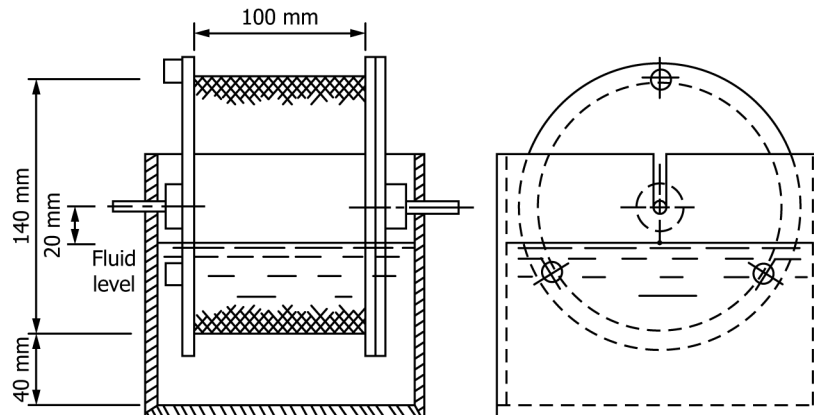

FIG. 1 Critical Dimensions of Slake Durability Device Showing Critical Dimensions

6.5 *Distilled Water.*

6.6 *Timer.*

6.7 *Camera.*

NOTE 3—Laboratory has the option of drying the test specimens in the drum or in a separate specimen's container. These containers are made of materials that are resistant to corrosion and change in mass upon repeated heating, cooling, and cleaning process. One uniquely numbered (identified) container or numbered-matched container, as required, is needed per each water content determination. After finishing each cycle, whole material from the specimen's container shall be transferred to number-matched drum or vice versa.

## 7. Sampling, Test Sample Specimens, and Specimen-Test Units

7.1 The samples shall be selected by visual observation to include a range of specimens based on rock type, mineral constituents, grain sizes and shape, partings, and defects such as pores and fissures. Collect, transport, and store test samples and test specimens in such a manner as to ~~retain~~ retain, as much as possible, the natural water content using the guidelines in Practices D2113 and D5079 and Test Method D2216.

7.2 The test specimen shall consist of ten representative, intact, roughly equidimensional shale fragments weighing 40 g to 60 g or other similar weak rock fragments with mass of 40-60 g each. These fragments may be naturally occurring or may be produced by breaking the samples with a hammer. Such fragments may be obtained from rock cores or from test pits, and their sizes will vary with the method of sampling. ~~Break off any sharp corners, if possible, sampling and density of sample. Also, break off any possible existing sharp corners,~~ and remove any dust by brushing the fragment just prior to weighing. ~~The total measuring the mass of the sample. The total mass of each test specimen shall weigh 450 to 550 be between 450-550 g.~~

## 8. Procedure

8.1 Photograph each specimen prior to placement in drum.

8.2 Measure mass of each empty drum or specimen container.

8.3 ~~Water Content~~—Using Test Method D2216, Method A, determine the water content and oven-dried mass of each test specimen before testing. This shall be done with the ~~shale test specimen fragments either in the drum or specimen container~~ to be used for the actual testing.

8.4 Mount the drum containing the dried test specimen in the trough and couple to the motor.

8.5 ~~Mount the drum in the trough and couple to the motor.~~ Fill the trough with distilled water at room temperature to 20 mm (0.8 in.) below the drum axis. Rotate the drum at 20 rpm for a period of 10 min. Record the water temperature at the beginning and end of the ~~run~~ test cycle.

8.6 Remove the drum from the trough immediately after the rotation period is ~~complete and complete.~~ Oven dry the ~~drum and the specimen retained in the oven the same specimen either in the drum or specimen container~~ as in 7.28.3 and obtain the oven-dried mass.

8.7 Repeat 7.38.4 and through 7.48.6 to obtain a final oven-dried mass for the second cycle.

8.8 Photograph specimen retained and file a copy of the photo with the laboratory report, or record standard verbal descriptions, as follows:

8.8.1 *Type I*—Retained ~~specimens~~ specimens remain virtually unchanged.

8.8.2 *Type II*—Retained ~~specimens~~ specimens consist of large and small fragments.

8.8.3 *Type III*—Retained ~~specimen is~~ specimens are exclusively small fragments.

8.9 See Fig. 2 for representative ~~photographs~~ photographs, each one of the three types.

## 9. Calculations

9.1 Calculate the slake durability index (~~second~~ (first and second cycle), as follows:

$$I_d(2) = [(W_F - C)/(B - C)] \times 100$$

$$I_{d1} = [(W_{f1} - C)/(W_i - C)] \times 100$$

$$I_{d2} = [(W_{f2} - C)/(W_i - C)] \times 100$$

where:

$I_d(2)$  = ~~slake durability index (second cycle),~~  
 $I_{d1}$  and  $I_{d2}$  = ~~slake durability index after first and second cycles accordingly, g,~~  
 $B$  = ~~mass of drum plus oven-dried specimen before the first cycle, g,~~  
 $W_i$  = ~~mass of drum plus oven-dried specimen before the first cycle, g,~~  
 $W_F$  = ~~mass of drum plus oven-dried specimen retained after the second cycle, g, and~~