



Designation: **E580/E580M – 14 E580/E580M – 16**

# Standard Practice for Installation of Ceiling Suspension Systems for Acoustical Tile and Lay-in Panels in Areas Subject to Earthquake Ground Motions<sup>1</sup>

This standard is issued under the fixed designation E580/E580M; the number immediately following the designation indicates the year of original adoption or, in the case of revision, the year of last revision. A number in parentheses indicates the year of last reapproval. A superscript epsilon ( $\epsilon$ ) indicates an editorial change since the last revision or reapproval.

*This standard has been approved for use by agencies of the U.S. Department of Defense.*

## 1. Scope\*

1.1 This practice covers the installation of suspended systems for acoustical tile and lay-in panels and their additional requirements for two groups of buildings that are constructed to resist the effects of earthquake motions as defined by ASCE 7 and the International Building Code. These groupings are for Seismic Design Category C and Seismic Design Categories D, E and F.

1.2 The authority having jurisdiction shall determine the applicability of this practice.

1.3 Specification C635 and Practice C636 cover suspension systems and their installation without special regard to seismic lateral restraint needs. They remain applicable and shall be followed when this practice is specified.

1.4 Ceilings less than or equal to 144 square feet and surrounded by walls connected to the structure above are exempt from the requirements of this practice.

1.5 This practice is not intended to stifle research and development of new products or methods. This practice is not intended to prevent the installation of any material or prohibit any design or method of construction not prescribed in this practice, provided that any such alternative has been substantiated by verifiable engineering data or full-scale dynamic testing that is acceptable to the authority having jurisdiction.

1.6 Ceiling areas of 1000 ft<sup>2</sup> [92.9 m<sup>2</sup>] or less shall be exempt from the lateral force bracing requirements of 5.2.8.

1.7 Ceilings constructed of gypsum board which is screw or nail attached to suspended members that support a ceiling on one level extending from wall to wall shall be exempt from the requirements of this practice.

1.8 Free floating ceilings (those not attached directly to any structural walls) supported by chains or cables from the structure are not required to satisfy the seismic force requirements provided they meet the following requirements:

1.8.1 The design load for such items shall equal 1.4 times the vertical operating weight.

1.8.2 Seismic interaction effects shall be considered in accordance with 5.7.

1.8.3 The connection to the structure shall allow a 360° range of motion in the horizontal plane.

1.9 The values stated in either inch-pound or SI units are to be regarded as standard. Within the text, the SI units are shown in brackets. The values stated in each system are not exact equivalents; therefore, each system shall be used independently of the other. Combining values from the two systems result in nonconformance with the specification.

1.10 *This standard does not purport to address all of the safety concerns, if any, associated with its use. It is the responsibility of the user of this standard to establish appropriate safety and health practices and determine the applicability of regulatory limitations prior to use.*

## 2. Referenced Documents

2.1 *ASTM Standards:*<sup>2</sup>

<sup>1</sup> This practice is under the jurisdiction of ASTM Committee E33 on Building and Environmental Acoustics and is the direct responsibility of Subcommittee E33.04 on Application of Acoustical Materials and Systems.

Current edition approved Jan. 15, 2014; Oct. 1, 2016. Published March 2014; November 2016. Originally approved in 1976. Last previous edition approved in 2011; 2014 as E580 – 14; E580/E580M – 14. DOI: 10.1520/E0580 – E0580M-14; 10.1520/E0580 – E0580M-16.

<sup>2</sup> For referenced ASTM standards, visit the ASTM website, www.astm.org, or contact ASTM Customer Service at service@astm.org. For *Annual Book of ASTM Standards* volume information, refer to the standard's Document Summary page on the ASTM website.

\*A Summary of Changes section appears at the end of this standard

C635 Specification for the Manufacture, Performance, and Testing of Metal Suspension Systems for Acoustical Tile and Lay-in Panel Ceilings

C636 Practice for Installation of Metal Ceiling Suspension Systems for Acoustical Tile and Lay-In Panels

2.2 Other Standards:

ASCE 7 Minimum Design Loads for Buildings and Other Structures<sup>3</sup>

CISCA Recommendations for Direct-hung Acoustical Tile and Lay-in Ceilings, Seismic Zones 0-2<sup>4</sup>

CISCA Guidelines for Seismic Restraint for Direct Hung Suspended Ceiling Assemblies, Seismic Zones 3 & 4<sup>4</sup>

International Building Code<sup>5</sup>

NFPA 70 National Electric Code<sup>6</sup>

3. Significance and Use

3.1 This practice is a prescriptive set of installation methods to be used for suspended ceilings and is often used in lieu of designing a separate lateral restraint system. The authority having jurisdiction shall determine the applicability of this practice to local code requirements.

3.2 This practice covers installation of suspended ceiling systems and related components in areas that require resistance to the effects of earthquake motions as defined by ASCE 7 and the International Building Code.

3.3 The practice is broken into two main sections. The first section covers areas with light to moderate earthquake potential (Seismic Design Category C) while the second deals with severe earthquake potential (Seismic Design Category D, E & F).

3.4 This practice includes requirements from multiple sources including previous versions of this practice, CISCA Seismic Recommendations for Direct-hung Acoustical Tile and Lay-in Ceilings, Seismic Zones 0-2 and CISCA Guidelines for Seismic Restraint for Direct Hung Suspended Ceiling Assemblies, Seismic Zones 3 & 4, suspended ceiling requirements from the International Building Code and ASCE 7. The purpose is to combine the requirements from these sources into a single comprehensive document.

4. Seismic Design Category C

NOTE 1—This section is intended to provide an unrestrained (free-floating) ceiling system that will accommodate the movement of the structure during a seismic event.

4.1 Suspension System Components:

4.1.1 The recommendations in this section are for ceilings systems with an average weight over the entire ceiling of 2.5 lb/ft<sup>2</sup> [12 N/m<sup>2</sup>] or less. This average weight includes suspension members, panels or tiles, light fixtures, supported flexible sprinkler drops and air terminals. (See 4.4 and 4.5 for details on lights and mechanical services.) Ceilings with an average weight over the entire ceiling greater than 2.5 lb/ft<sup>2</sup> [12 N/m<sup>2</sup>] shall be installed as specified in Section 55.1 taking into account the design lateral forces appropriate for Category C. Other deviations or variations shall be substantiated by verifiable engineering data or full-scale dynamic testing.

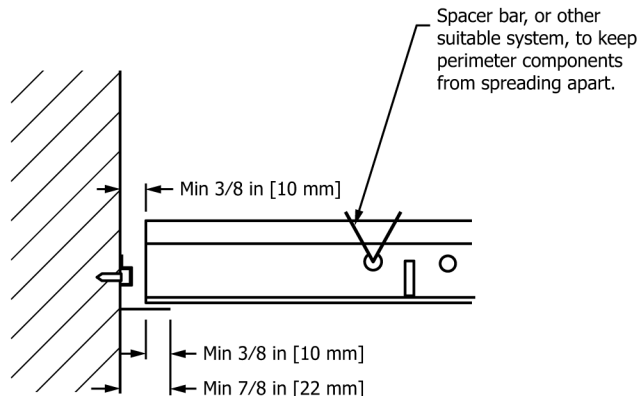

FIG. 12 Category C Treatment of Cross Runners, Main Runners, and Wall Closures at Terminal Ends

4.1.2 The main runners and cross runners of the ceiling system and their splices, intersection connectors, and expansion devices shall be designed and constructed to carry a mean ultimate test load of not less than 60 lb [27 kg] in tension and in compression. The tensile test shall allow for a 5° offset of the connection in any direction. Instead of a 5° misalignment, the load can be applied with a 1-in. [25-mm] eccentricity on a sample not more than 24 in. [600 mm] long on each side of the splice.

4.1.3 Evaluation of test results shall be made on the mean values resulting from tests on a minimum of three identical specimens. If the deviation of any individual test result exceeds ±10 % from the mean value, three additional samples shall be tested. After the required testing on the six specimens is complete. Drop the high and low test values and use the remaining four test results to obtain the mean test value average. If one of the remaining test results still exceeds the ±10 % mean value, the lowest individual test value recorded from the six test will be used as the reported test result.

4.2 *Suspension System Application:*

4.2.1 Unless perimeter members meet the structural load carrying requirements and have been approved as a structural part of the system, wall angles or channels shall be considered as aesthetic closers and shall have no structural value assessed to themselves or their method of attachment to the walls.

4.2.2 All perimeter closure angles or channels shall provide a support ledge of 7/8 in. [22 mm] or greater unless the perimeter ends of each cross runner and main runner shall be independently supported as specified in 4.2.1.

4.2.3 When a perimeter closure angle that provides less than 7/8 in. [22 mm] has been approved for use, the perimeter ends of each cross runner and main runner shall be independently supported within 8 in. [200 mm] from each wall or ceiling discontinuity (see Fig. 31).

4.2.4 The terminal ends of suspension members shall have a minimum of 3/8-in. [9-mm] clearance from the wall as shown in Fig. 42. Reveal (shadow) edge wall closures with these clearances are shown in Fig. 23.

4.2.5 Terminal ends of main runners and cross runners shall be prevented from spreading.

4.2.6 Permanent runner end attachment (i.e., (that is, pop rivets) for grid alignment purposes shall not be permitted.

4.2.7 All ceiling penetrations (columns, sprinklers, etc.) and independently supported fixtures or services shall have a minimum of 0.375-in. [9-mm] clearance on all sides by using suitable escutcheons or perimeter closure details.

4.3 *Suspension Wire Application:*

4.3.1 Suspension wires that are a minimum of No. 12 gauge [2.70 mm] galvanized, soft-annealed, mild steel wire shall be spaced at 4 ft [1200 mm] on center along each main runner, unless engineering calculations justifying increased spacing are provided.

4.3.2 Each vertical wire shall be attached to the ceiling suspension member and to the support above such that the wire loops shall be tightly wrapped and sharply bent to prevent any vertical movement or rotation of the member within the loops. The wire must be wrapped around itself a minimum of three full turns (360° each) within a 3-in. [75-mm] length. Connection devices to the supporting construction shall be capable of carrying not less than a 90-lb [40-kg] allowable load.

4.3.3 Suspension wires shall not hang more than one in six out of plumb unless countersloping wires are provided.

<https://standards.iteh.ai/catalog/standards/sist/8660271d-ae80-4fbb-9bf9-76c2fa5d6244/astm-e580-e580m-16>

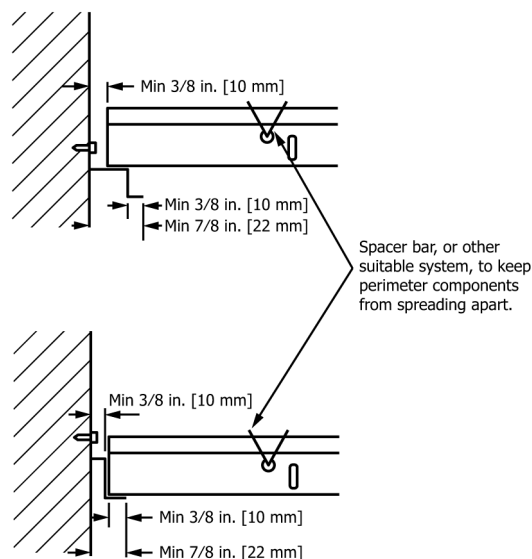

FIG. 23 Category C Treatment of Cross Runners and Main Runners at Terminal Ends When Using Reveal (Shadow) Edge Wall Closures

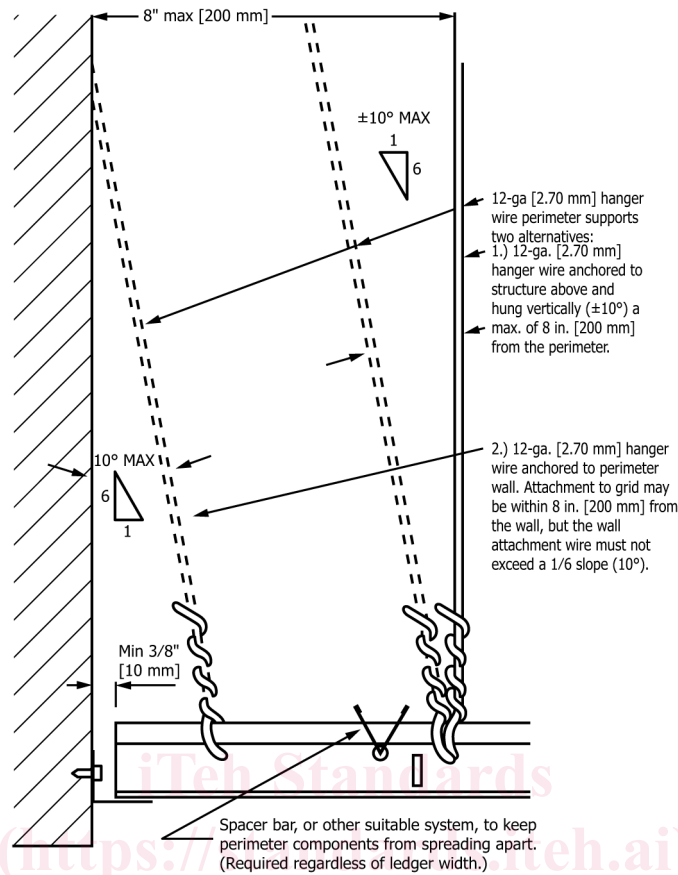

FIG. 31 Category C Treatment of Cross Runners and Main Runners at Terminal Ends When Support Ledge of Perimeter Closure is Less Than Minimum 7/8 in. [22 mm]

4.3.4 Wires shall not attach to or bend around interfering material or equipment. A trapeze or equivalent device shall be used where obstructions preclude direct suspension. Trapeze suspensions shall be sized to resist the dead load and lateral forces appropriate for Category C.

#### 4.4 Light Fixture Application:

4.4.1 All lighting fixtures shall be positively attached to the suspended ceiling system by mechanical means as specified in the National Electrical Code unless independently supported. The attachment device shall have the capacity of supporting 100 % of the lighting fixture weight acting in any direction. A minimum of two attachment devices are required for each fixture.

4.4.2 Surface-mounted lighting fixtures shall be attached to the ceiling system with a positive clamping device that completely surround the supporting members. Safety wires shall be attached between the clamping device and the adjacent ceiling hanger or to the structure above. In no case shall the fixture exceed the design carrying capacity of the supporting members.

4.4.3 Lighting fixtures weighing less than or equal to 10 lb [5 kg] shall have one, No. 12-gauge [2.70 mm] safety wire connected from the fixture housing (not the detachable end plates) to the structure above. It is not necessary for these safety wires to be taut. Supplementary hanger wires of cross tees supporting light fixtures shall not be required.

4.4.4 Lighting fixtures weighing greater than 10 lbs [5kg] but less than or equal to 56 lb [25 kg] shall have two No. 12-gauge [2.70 mm] safety wires connected from the fixture housing (not the detachable end plates) to the structure above that act as safety wires. It is not necessary for these safety wires to be taut.

4.4.5 Lighting fixtures weighing greater than 56 lb [25 kg] or more shall be supported directly from the structure above by approved hangers.

4.4.6 Pendant-hung lighting fixtures shall be supported directly from the structure above using no less than No. 9-gauge [3.80 mm] wire or an approved alternate support. The ceiling suspension system shall not provide any direct support.

4.4.7 Rigid conduit is not permitted for attachment of the fixtures.

#### 4.5 Services within the Ceiling:

4.5.1 Flexible sprinkler hose fittings, ceiling mounted air terminals or other services weighing less than or equal to 20 lb [9 kg] shall be positively attached to the ceiling suspension main runners or cross runners that have the same carrying capacity as the main runners.

4.5.2 Flexible sprinkler hose fittings, air terminals or other services weighing more than 20 lb [9 kg] but less than or equal to 56 lb [25 kg] shall have, in addition to the requirements in 4.5.1, two No. 12-gauge [2.70 mm] hanger wires connected from the terminal or service to the ceiling system hangers or to the structure above that act as safety wires. It is not necessary for these wires to be taut.

4.5.3 Flexible sprinkler hose fittings, air terminals or other services weighing more than 56 lb [25 kg] shall be supported directly from the structure above by approved hangers.

4.6 *Partition Application to Suspended Ceilings:*

4.6.1 The ceiling system shall not provide lateral support for walls or partitions. Walls or partitions shall only be attached to the ceiling suspension provided they allow the ceiling membrane to move laterally to accommodate the required clearance as specified in 4.2.4.

## 5. Seismic Design Category D, E & F

NOTE 2—The objective of this section is to provide a restrained ceiling through either connection to the perimeter wall, or through bracing either rigid or non-rigid. The key to good seismic performance of this type of ceiling is that the width of the closure angle around the perimeters are adequate to accommodate ceiling motion and that penetrations, such as columns and piping, have adequate clearance to avoid concentrating restraining loads on the ceiling system.

5.1 *Suspension System Components:*

5.1.1 Only heavy-duty main tees as defined in Specification C635 shall be used.

5.1.2 The main runners and cross runners of the ceiling system and their splices, intersection connectors, and expansion devices shall be designed and constructed to carry a mean ultimate test load of not less than 180 lb [80 kg] in compression and in tension. The tensile test shall allow for a 5° offset of the connection in any direction. Instead of a 5° misalignment, the load can be applied with a 1-in. [25-mm] eccentricity on a sample not more than 24 in. [600 mm] long on each side of the splice or intersection. The connectors at splices and intersections shall be the mechanical interlocking type.

5.1.3 Evaluation of test results shall be made on the mean values resulting from tests on a minimum of three identical specimens. If the deviation of any individual test result exceeds  $\pm 10\%$  from the mean value, three additional samples shall be tested. After the required testing on the six specimens is complete. Drop the high and low test values and use the remaining four test results to obtain the mean test value average. If one of the remaining test results still exceeds the  $\pm 10\%$  mean value, the lowest individual test value recorded from the six test will be used as the reported test result.

5.2 *Suspension System Application:*

5.2.1 Unless perimeter members are a structural part of the approved system and meet the structural load carrying requirements, wall angles or channels shall be considered as aesthetic closers and shall have no structural value assessed to themselves or their method of attachment to the walls.

5.2.2 The perimeter support angle shall supply a support ledge of not less than 2 in. [50 mm].

5.2.3 Main runner and/or cross runner ends shall be attached to the perimeter on two adjacent walls. A clearance of  $\frac{3}{4}$  in. [18 mm] shall be maintained between the main runner and cross runner ends and the perimeter members on the two opposite walls (see Fig. 4 Fig. 5 Fig. 76). On the walls where the terminal end runners are not fixed to the perimeter supporting closure, allow for  $\frac{3}{4}$  in. [18 mm] axial movement.

5.2.4 Terminal ends of main runners and cross runners not attached to the perimeter closure angle or channel, shall be prevented from spreading.

5.2.5 Direct concealed suspended ceiling systems shall have positively connected stabilizer bars or mechanically connected cross runners at a maximum spacing of 60 in. [1500 mm] perpendicular to the main runners. Stabilization shall occur within 24 in. [600 mm] of each wall.

5.2.6 The terminal end of each cross runner and main runner shall be supported independently, a maximum of 8 in. (200 mm) from each wall or ceiling discontinuity with No. 12-gauge [2.70 mm] wire or approved wall support. See Fig. 76.

5.2.7 *Suspension Wire Application:*

5.2.7.1 Suspension wires of galvanized, soft-annealed, mild steel wire shall not be smaller than No. 12 gauge [2.70 mm] spaced at 4 ft [1200 mm] on center along each main runner unless calculations justifying the increased spacing or alternate materials are provided.

5.2.7.2 Each vertical wire shall be attached to the ceiling suspension member and to the support above such that the wire loops shall be tightly wrapped and sharply bent to prevent any vertical movement or rotation of the member within the loops. The wire must be wrapped around itself a minimum of three full turns (360° each) within a 3-in. [75-mm] length. Connection devices to the supporting construction shall be capable of carrying not less than a 90-lb [40-kg] allowable load.

5.2.7.3 Suspension wires shall not hang more than one in six out of plumb unless countersloping wires are provided.

5.2.7.4 Wires shall not attach to or bend around interfering material or equipment. A trapeze or equivalent device shall be used where obstructions preclude direct suspension. Trapeze suspensions shall be sized to resist the dead load and lateral forces appropriate for the seismic design category.

5.2.8 *Lateral Force Bracing:*

5.2.8.1 Lateral force bracing is required for all ceiling areas greater than 1000 ft<sup>2</sup> [92.9 m<sup>2</sup>].



Lateral Bracing Layout for Seismic Design Categories D, E, & F

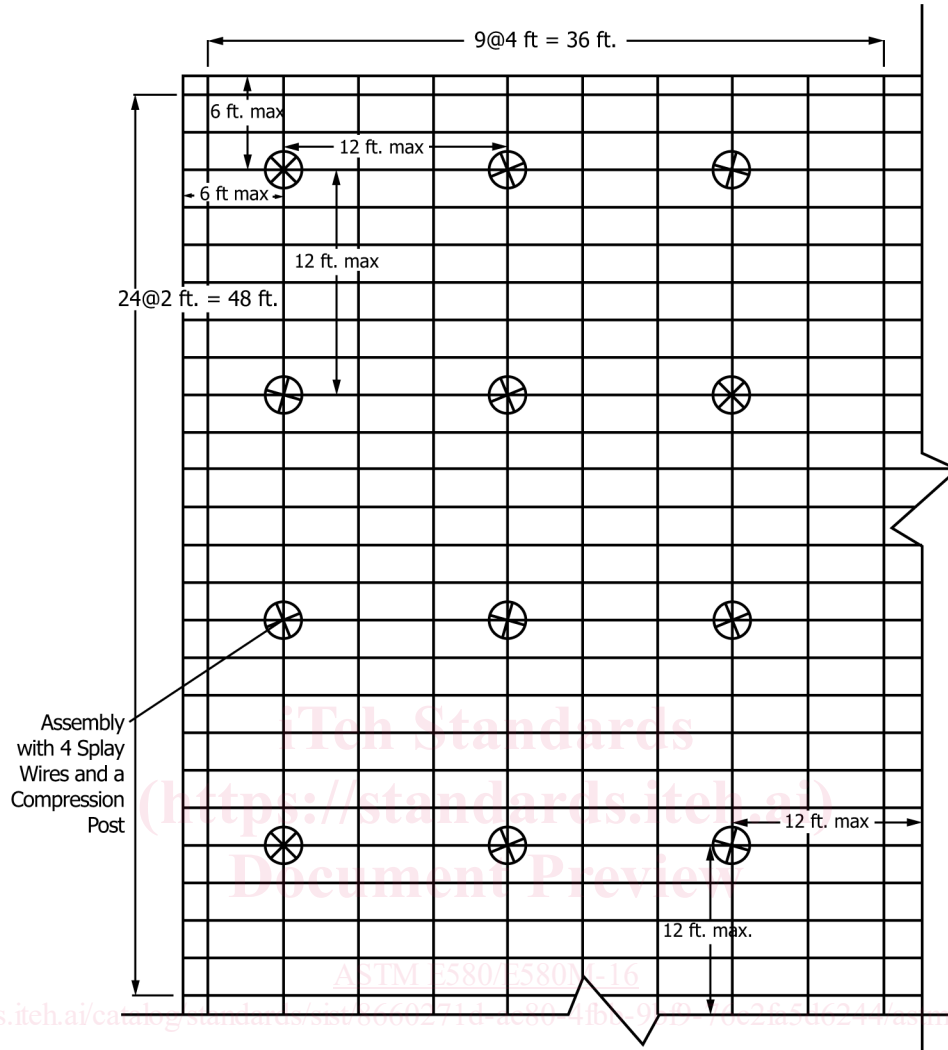

FIG. 4 Categories D, E, & F Seismic Bracing Layout Illustration

5.2.8.2 Horizontal restraints shall be effected by four No. 12-gauge [2.70 mm] wires secured to the main runner within 2 in. [50 mm] of the cross runner intersection and splayed 90° from each other at an angle not exceeding 45° from the plane of the ceiling. A strut fastened to the main runner at the location of the bracing wires shall be extended to and fastened to the structural members supporting the roof or floor above. The strut shall be adequate to resist the vertical component induced by the bracing wires. These horizontal restraint points shall be placed 12 ft [3600 mm] on center in both directions with the first point within 6 ft [1800 mm] from each wall. Attachment of the restraint wires to the structure above and to the main runner shall be adequate for the load imposed. See Fig. 57.

5.2.8.3 Lateral force bracing members shall be spaced a minimum of 6 in. [150 mm] from all horizontal piping or duct work that is not provided with bracing restraints for horizontal forces. Bracing wire shall be attached to the grid and to the structure in such a manner that they can support a load of not less than 250 lb [115 kg].

5.2.8.4 Rigid braces that have been designed to limit relative lateral deflections at the point of attachment of the ceiling grid to less than 0.25 in. [6 mm] are permitted to be used in the place of diagonal splay wires.

5.2.8.5 Except where rigid bracing is used or substantiating design calculations have shown that lateral deflections are limited to less than 0.25 in. [6 mm], sprinkler heads and other penetrations shall have a 2-in. [50-mm] oversize ring, sleeve or adapter through the ceiling tile to allow for free movement of at least 1 in. [25 mm] in all horizontal directions. Alternatively, a flexible sprinkler hose fitting that can accommodate 1 in. [25 mm] of ceiling movement shall be permitted to be used without the oversized ring, sleeve or adapter.

5.2.8.6 Changes in ceiling plane elevation shall have independent positive bracing.

5.2.8.7 Cable trays & electrical conduits shall be supported and braced independently of the ceiling.