

---

# INTERNATIONAL STANDARD



# 3939

---

INTERNATIONAL ORGANIZATION FOR STANDARDIZATION • МЕЖДУНАРОДНАЯ ОРГАНИЗАЦИЯ ПО СТАНДАРТИЗАЦИИ • ORGANISATION INTERNATIONALE DE NORMALISATION

---

## Fluid power systems and components — Multiple lip packing sets — Methods for measuring stack heights

*Transmissions hydrauliques et pneumatiques — Garnitures à lèvres multiples — Méthodes de mesurage des hauteurs d'empilage*

First edition — 1977-03-15

iTeh STANDARD PREVIEW  
(standards.iteh.ai)

[ISO 3939:1977](https://standards.iteh.ai/catalog/standards/sist/24722d95-b0b0-4cdd-bbb4-03cc320984f1/iso-3939-1977)

<https://standards.iteh.ai/catalog/standards/sist/24722d95-b0b0-4cdd-bbb4-03cc320984f1/iso-3939-1977>



---

UDC 621.8.032

Ref. No. ISO 3939-1977 (E)

**Descriptors** : pneumatic equipment, hydraulic equipment, fluid power, dimensional measurement, seals (stoppers).

Price based on 4 pages

## FOREWORD

ISO (the International Organization for Standardization) is a worldwide federation of national standards institutes (ISO member bodies). The work of developing International Standards is carried out through ISO technical committees. Every member body interested in a subject for which a technical committee has been set up has the right to be represented on that committee. International organizations, governmental and non-governmental, in liaison with ISO, also take part in the work.

Draft International Standards adopted by the technical committees are circulated to the member bodies for approval before their acceptance as International Standards by the ISO Council.

International Standard ISO 3939 was developed by Technical Committee ISO/TC 131, *Fluid power systems and components*, and was circulated to the member bodies in October 1975.

iteh STANDARD PREVIEW  
(standards.iteh.ai)

It has been approved by the member bodies of the following countries :

[ISO 3939:1977](#)

Australia	India	Spain
Austria	Japan	Sweden
Belgium	Korea, Dem. P. Rep. of	Turkey
Brazil	Mexico	United Kingdom
Czechoslovakia	Netherlands	U.S.A.
Finland	Poland	Yugoslavia
France	Romania	
Germany	South Africa, Rep. of	

No member body expressed disapproval of the document.

# Fluid power systems and components – Multiple lip packing sets – Methods for measuring stack heights

## iTeh STANDARD PREVIEW

(standards.iteh.ai)

### 0 INTRODUCTION

In fluid power systems, power is transmitted and controlled through a fluid (liquid or gas) under pressure within an enclosed circuit. Packing sets are used to contain the pressurized fluid within components with movable elements.

Various methods are currently being used by different suppliers and users to measure the stack height of packing sets. This frequently results in different values being obtained, owing to the nature of the materials used for seals and to the fact that a number of individual sealing rings are being measured together. Traditional measuring tools (for example sliding calipers) cannot be accurately applied in such circumstances. In addition, results are greatly influenced by the ability of the individual inspector.

Cylinder, valve and pump designers, quality control personnel, and inspection personnel need accurate stack height dimensions of multiple lip packing sets to do their work effectively. By having these dimensions, users and suppliers can work from a standard base when communicating seal requirements. Inspection upon receipt is facilitated for the user, as is final inspection for the supplier; and both have the opportunity of ensuring understanding concerning what has been received and what has been supplied. Having these dimensions also provides designers with an understanding and a means for determining final installation conditions.

### 1 SCOPE AND FIELD OF APPLICATION

This International Standard specifies methods for measuring sealing devices having more than one seal in the set. The sets are composed of homogeneous and/or fabric-reinforced fluid power lip sealing rings of various configurations such as V, Y, U and W, with or without adapters.

This International Standard also specifies methods for measuring stack height of multiple lip packing sets in order that both supplier and user can determine that the sets are to an acceptable dimensional standard.

It is not the intention of this International Standard to specify the dimensions for packing sets or their components, since such dimensions depend on the material being used, on the section and on the type of design.

### 2 REFERENCE

ISO 5598, *Fluid power systems and components – Vocabulary*.

### 3 DEFINITIONS

For definitions of terms used, see ISO 5598.

### 4 GENERAL

4.1 This International Standard describes three acceptable methods for determining the stack height of a multiple lip packing set. Each method has distinct advantages and disadvantages. However, there is a reasonable degree of correlation among these three methods, and users are advised to consult their suppliers to determine which of the three methods the supplier is currently using.

4.2 It is recommended that the user consult the seal supplier to ascertain the method of measuring used and the applicable data, thus enabling the user to duplicate the supplier's method or correlate results if supplier and user methods are different.

4.3 The following are some considerations that the user and the supplier should bear in mind in determining which method they propose to adopt.

4.3.1 *Method 1*

Unconfined (preferred): recommended for diameters up to 200 mm (approximately)

4.3.1.1 This method is very widely used by both suppliers and users throughout the world. This method, while usable for larger (over 200 mm) diameter sets by measuring a number of circumferential sections of the set, is the recommended method for smaller (under 200 mm) diameter sets.

4.3.1.2 Essentially, only flat parallel plates and weights are required. See figure 1.

4.3.1.3 The user is cautioned that the resultant stack height under the checking load may not be the stack height in the seal housing.

4.3.2 *Method 2*

Confined at one point : recommended for diameters over 200 mm (approximately)

4.3.2.1 This method, while usable for smaller (under 200 mm) sets, is recommended for larger diameter sets.

4.3.2.2 The apparatus for this method is two parallel rods or pillars mounted on a rigid base plate, with the gap between the pillars being adjustable. See figure 2.

4.3.2.3 The user is cautioned that the resultant stack height under the checking load may not be the stack height in the seal housing.

4.3.3 *Method 3*

Confined I.D. and O.D.

4.3.3.1 This method may be used for initial testing, and is normally correlated with method 1 or 2 for high quantity production.

4.3.3.2 To use this method, a set of accurate I.D. (plug) and O.D. (ring) gauges and a follower ring are required for each size under consideration. The gauges are designed to duplicate the relevant seal housing, providing a stack height measurement which relates to that of the set in the seal housing.

4.3.3.3 Faulty readings may occur due to air entrapment or excessive friction. This risk can be minimized by providing air ways in the gauges, by ensuring that the surface finishes of users' and suppliers' gauges are identical and by maintaining clean, undamaged and dry gauges.

4.4 **Checking load**

4.4.1 A checking load (*P*) is required with each method. The amount of the checking load depends on the shape and material of the packing set and must be a value that nests the packing set components but does not deform them. The load must be agreed to by the supplier and user and can be determined as follows :

4.4.1.1 For method 1 and method 3, the load can be calculated from the mean diameter ( $D_m$ ) of the packing set, the nominal radial cross-section of the packing set (C.S.) and a specific testing load ( $P_{spec}$ ), i.e.

$$P = (D_m) (C.S.) (P_{spec})$$

4.4.1.2 For method 2, the load can be calculated from the nominal radial cross-section (C.S.) of the packing set and a specific testing load ( $P_{spec}$ ), i.e.

$$P = (C.S.) (P_{spec})$$

4.4.2 A preload is required for method 3 and, if desired by the supplier and user, may be used with method 1 or 2.

4.4.3 When calculating the checking loads, give consideration to components of the test setup which may contribute to the applied load.

iTeh STANDARD PREVIEW  
(standards.iteh.ai)

ISO 3939:1977  
5 **METHOD FOR MEASURING STACK HEIGHT**

5.1 **Method 1 : Unconfined**

5.1.1 Centre the packing set on the lower plate of the measuring device. A typical device is shown in figure 1.

5.1.2 Apply a preload, if desired, to seat the packing.

5.1.3 Apply the checking load (see 4.4) and measure the stack height.

5.2 **Method 2 : Confined at one point**

5.2.1 Set pillars to nominal radial cross-section of seal housing. A typical device is shown in figure 2.

5.2.2 Insert the packing set, male adapter first, between the pillars of the device as shown in figure 3.

5.2.3 Ensure that the male adapter is in contact with the base plate of the device. Apply the checking load (see 4.4) axially between the pillars.

5.2.4 Measure the depth of set between the pillars. The average of measurements at a number of equidistant points shall be taken. The number of measurements shall be agreed to by the supplier and user.

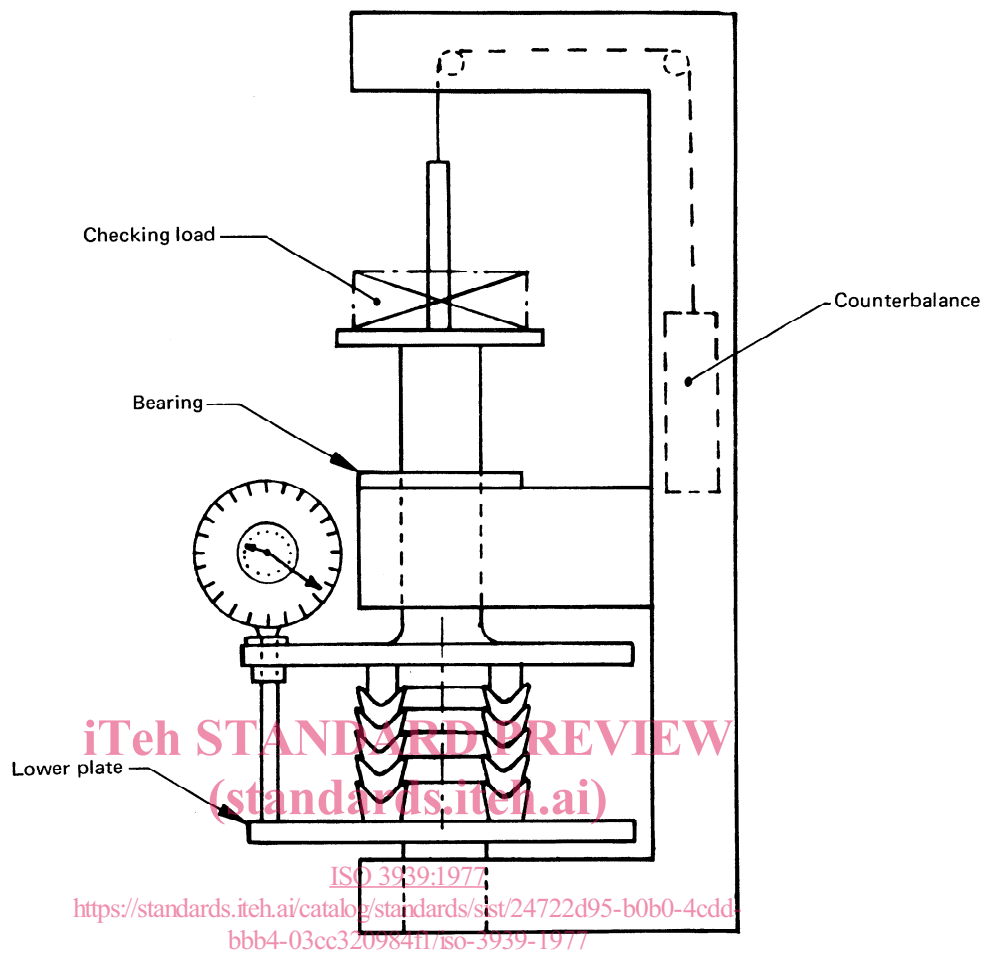

FIGURE 1 – Typical measuring device for method 1 and method 2

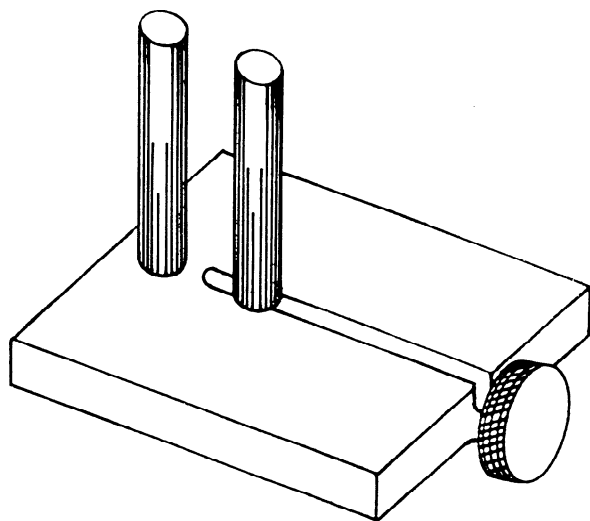

FIGURE 2 – Typical device for method 2

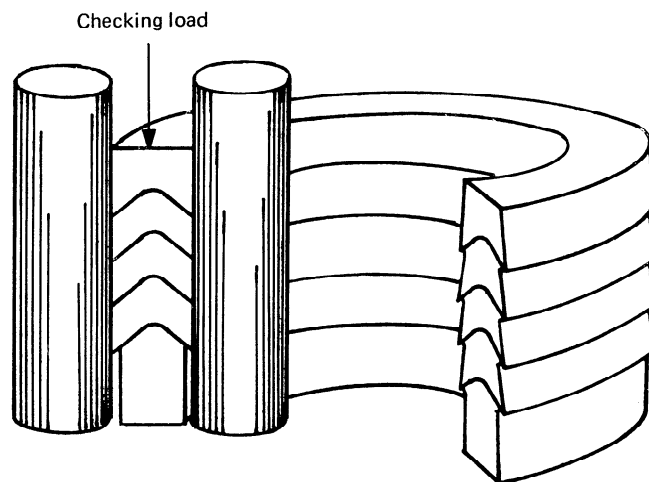

FIGURE 3 – Typical setup for method 2

**5.3 Method 3 : Confined I.D. and O.D.**

**5.3.1** Insert the packing set, female adapter first, into the O.D. ring.

**5.3.2** Turn the assembly over. Insert the I.D. plug into the set (from the female adapter end). See example in figure 4.

**5.3.3** Insert the follower ring.

**5.3.4** Centre the unit on the base plate of the measuring device or fixture as used for method 1 (see figure 1). Apply a preload to seat the packing.

**5.3.5** Take care to ensure that there is no air entrapment

between the seals, or abnormal friction between the packing and the gauges. These can cause faulty readings.

**5.3.6** Remove the preload. Apply the checking load (see 4.4) and measure the stack height.

**6 IDENTIFICATION STATEMENT (Reference to this International Standard)**

Use the following statement in test reports, catalogues and sales literature when electing to comply with this International Standard :

“The method of measuring conforms to method . . . of ISO 3939, *Fluid power systems and components – Multiple lip packing sets – Methods for measuring stack heights.*”

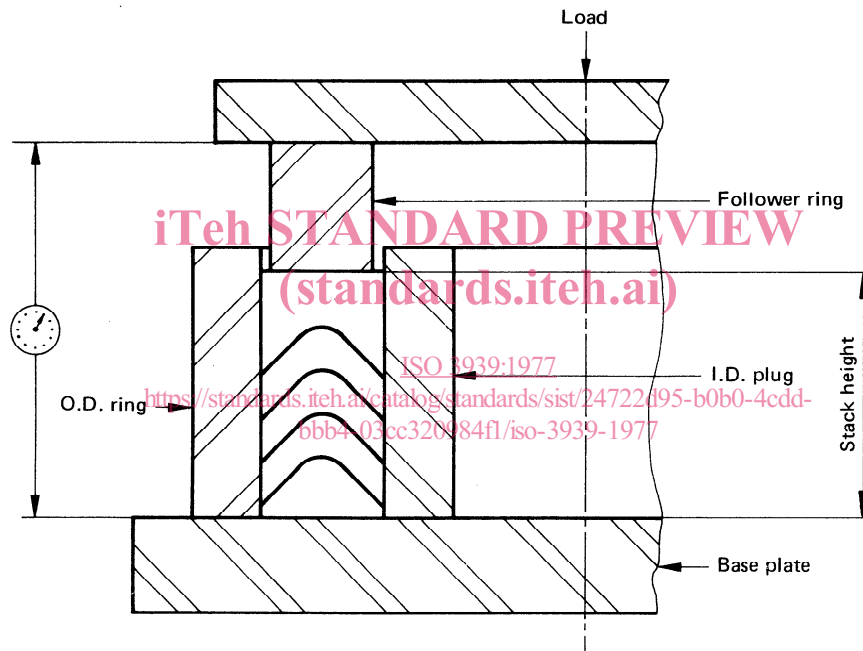

FIGURE 4 – Typical setup for method 3

**iTeh STANDARD PREVIEW**  
**(standards.iteh.ai)**

This page intentionally left blank

[ISO 3939:1977](#)

<https://standards.iteh.ai/catalog/standards/sist/24722d95-b0b0-4cdd-bbb4-03cc320984f1/iso-3939-1977>

**iTeh STANDARD PREVIEW**  
**(standards.iteh.ai)**

This page intentionally left blank

[ISO 3939:1977](#)

<https://standards.iteh.ai/catalog/standards/sist/24722d95-b0b0-4cdd-bbb4-03cc320984f1/iso-3939-1977>