



Designation: D7577 – 12 (Reapproved 2016)

Standard Test Method for Determining the Accelerated Iron Corrosion Rating of Denatured Fuel Ethanol and Ethanol Fuel Blends¹

This standard is issued under the fixed designation D7577; the number immediately following the designation indicates the year of original adoption or, in the case of revision, the year of last revision. A number in parentheses indicates the year of last reapproval. A superscript epsilon (ϵ) indicates an editorial change since the last revision or reapproval.

1. Scope

1.1 This test method measures the ability of inhibited and uninhibited Ethanol Fuel Blends defined by Specification D5798 and Denatured Fuel Ethanol defined by Specification D4806 to resist corrosion of iron should water become mixed with the fuel, using an accelerated laboratory test method. Corrosion ratings are reported based on a visual, numbered rating scale.

1.2 The values stated in SI units are to be regarded as standard. The values in parentheses are for information only.

1.3 *This standard does not purport to address all of the safety concerns, if any, associated with its use. It is the responsibility of the user of this standard to establish appropriate safety and health practices and determine the applicability of regulatory limitations prior to use.* Specific hazard statements are given in Sections 7 and 8.

2. Referenced Documents

2.1 ASTM Standards:²

- A29/A29M Specification for General Requirements for Steel Bars, Carbon and Alloy, Hot-Wrought
- A108 Specification for Steel Bar, Carbon and Alloy, Cold-Finished
- D665 Test Method for Rust-Preventing Characteristics of Inhibited Mineral Oil in the Presence of Water
- D1193 Specification for Reagent Water
- D2699 Test Method for Research Octane Number of Spark-Ignition Engine Fuel
- D4175 Terminology Relating to Petroleum Products, Liquid Fuels, and Lubricants
- D4806 Specification for Denatured Fuel Ethanol for Blending with Gasolines for Use as Automotive Spark-Ignition Engine Fuel

¹ This test method is under the jurisdiction of ASTM Committee D02 on Petroleum Products, Liquid Fuels, and Lubricants and is the direct responsibility of Subcommittee D02.14 on Stability and Cleanliness of Liquid Fuels.

Current edition approved Oct. 1, 2016. Published November 2016. Originally approved in 2012. Last previous edition approved in 2012 as D7577 – 12. DOI: 10.1520/D7577-12R16.

² For referenced ASTM standards, visit the ASTM website, www.astm.org, or contact ASTM Customer Service at service@astm.org. For *Annual Book of ASTM Standards* volume information, refer to the standard's Document Summary page on the ASTM website.

- D5798 Specification for Ethanol Fuel Blends for Flexible-Fuel Automotive Spark-Ignition Engines
- E177 Practice for Use of the Terms Precision and Bias in ASTM Test Methods
- E2251 Specification for Liquid-in-Glass ASTM Thermometers with Low-Hazard Precision Liquids

3. Terminology

3.1 Definitions:

3.1.1 For definitions of terms used in this test method, refer to Terminology D4175.

3.1.2 *Fuel C, n*—a volumetric mixture of 50 volume percent reference fuel grade toluene and 50 volume percent reference fuel grade isooctane.

3.1.2.1 *Discussion*—Specifications for reference fuel grade toluene and reference fuel grade isooctane can be found in Test Method D2699.

3.2 Abbreviations:

3.2.1 *HDPE, n*—high density polyethylene

3.2.2 *PTFE, n*—Polytetrafluoroethylene

4. Summary of Test Method

4.1 A polished steel test rod is immersed in a mixture of the test sample and water at a ratio of 10 parts fuel sample to 1 part water and held at a temperature of 37 °C to 39 °C (98 °F to 102 °F) for 1 h.

4.2 At the end of 1 h, the test rod is removed, rinsed and rated according to a numeric corrosion rating scale.

5. Significance and Use

5.1 This test is designed to be used as a rapid measure of the overall relative corrosivity of Ethanol Fuel Blends (Specification D5798) and Denatured Fuel Ethanol (Specification D4806) to iron (steel).

5.2 The test can be used to compare corrosion inhibitor dosage levels and effectiveness of various corrosion inhibitors as they pertain to protecting iron (steel) materials from corrosion.

6. Apparatus

6.1 *General*—Two test apparatus have been evaluated and found to give comparable results.

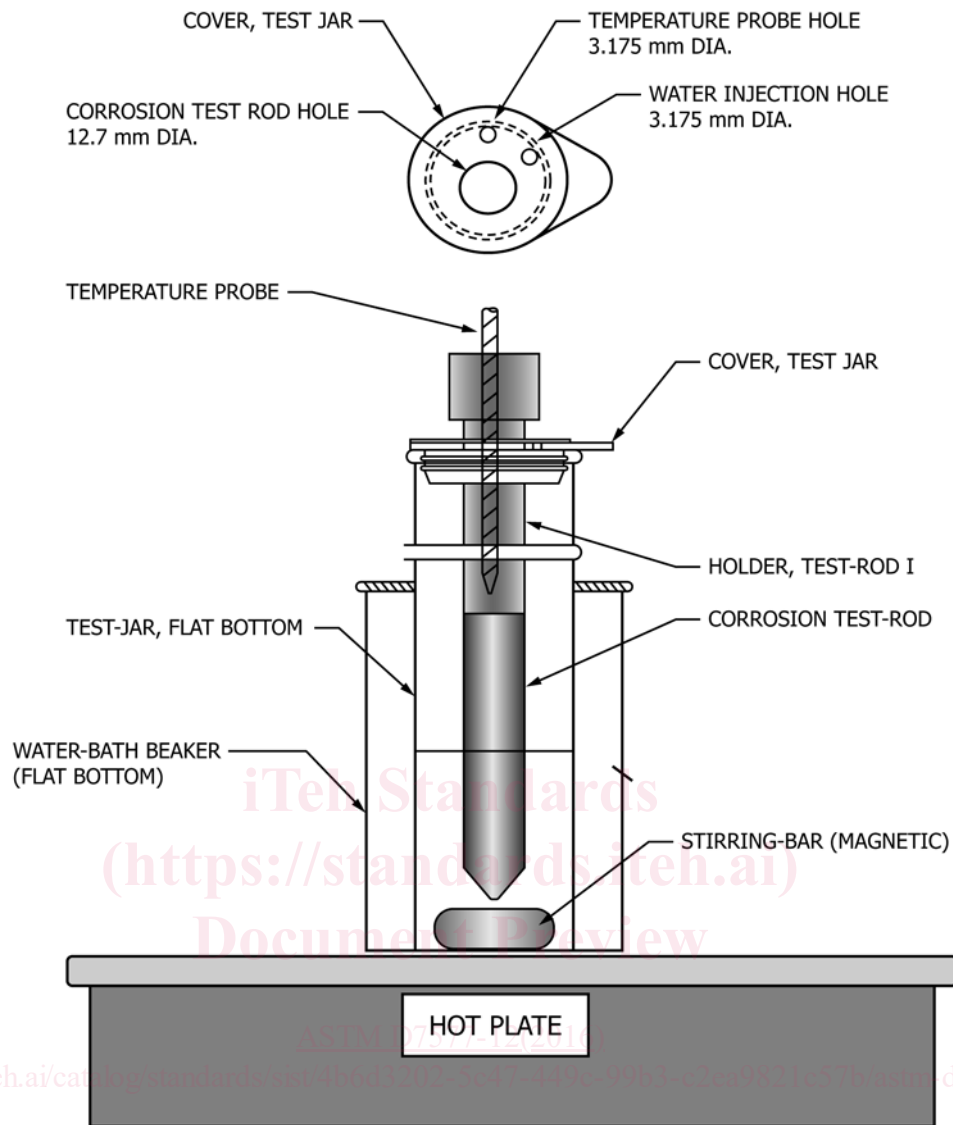

FIG. 1 Recommended Small Volume Test Apparatus

6.1.1 Large sample volume (300 mL) apparatus specified in Test Method **D665**.

6.1.2 Small sample volume (30 mL to 75 mL) apparatus specified in **6.2**.

6.2 *Small Volume Test Apparatus* (Fig. 1).

6.2.1 Compared to Test Method **D665**, the small volume test apparatus is lower in cost and allows for use of smaller volumes of samples to improve the safety of the measurement. Different apparatus and components that achieve the same results may be used.

6.2.2 Hot plate/stir plate or water bath capable of maintaining a temperature of 37 °C to 39 °C (98 °F to 102 °F) and stirring at a rate of 900 r/min ± 100 r/min.

6.2.3 150 mL to 200 mL borosilicate glass beakers to hold water to serve as a water bath.

6.2.4 50 mL to 150 mL borosilicate, flat bottom, glass test jar to hold test sample.

6.2.5 Jar covers made of HDPE or other material compatible with ethanol, water and gasoline with three holes:

6.2.5.1 A hole to suspend the steel test rod into the test sample,

6.2.5.2 A hole for the thermometer,

6.2.5.3 A hole for inserting a syringe needle to add water to the test sample.

6.2.6 PTFE (polytetrafluoroethylene) coated magnetic stir bar.

6.2.7 The small volume test apparatus shall be designed so that at least 50 % of the test rod surface is below the surface of the test material.

6.3 *Grinding and sanding apparatus*, capable of rotating the steel test rod at 1700 r/min to 1800 r/min for manual sanding.

6.4 *Timing device*, capable of taking readings with a discrimination of 1 min or better.

6.5 *Analytical balance*, at least 100 g capacity, capable of weighing accurately to at least 0.001 g.

6.6 *Temperature measuring device*, Any thermometer with a temperature range that includes 37 °C to 39 °C (89 °F to

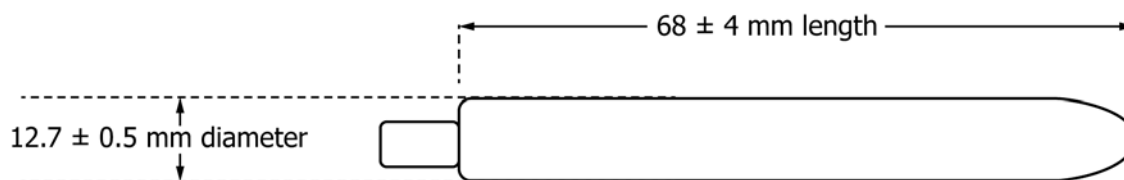

FIG. 2 Dimensions of New Steel Test Rod

102 °F), with one degree graduation subdivisions and conforming to the requirements prescribed in Specification E2251. Alternatively, calibrated thermocouples may be used.

7. Reagents and Materials

7.1 *Water*—References to water shall be understood to mean reagent water of grade Specification D1193 Type II or better.

7.2 *Purity of Reagents*—Reagent grade chemicals shall be used in all tests. Unless otherwise indicated, it is intended that all reagents shall conform to the specifications of the committee on Analytical Reagents of the American Chemical Society, where such specifications are available.³ Other grades may be used, provided it is first ascertained that the reagent is of sufficiently high purity to permit its use without lessening the accuracy of the determination.

7.2.1 *Acetic acid*—(Warning—Corrosive. Health hazard.)

7.2.2 *Acetone*—(Warning—Flammable. Health hazard.)

7.2.3 *Formic acid*—(Warning—Corrosive. Health hazard.)

7.2.4 *Isooctane (2,2,4-trimethylpentane)*—(Warning—Flammable. Health hazard.)

7.2.5 *Reagent alcohol*—(Warning—Flammable. Health hazard.)—containing 90 volume % ethanol, 5 volume % isopropanol, 5 volume % methanol and <0.1 volume % water.

NOTE 1—The specified reagent alcohol must be used to achieve equivalent results and ratings to that reported in this test method.

7.2.6 *Sodium chloride*.

7.2.7 *Toluene*—(Warning—Flammable. Health hazard.)

7.2.8 *Fuel C*—A mixture of 50 volume percent toluene and 50 volume percent isooctane.

7.3 *Polishing Material*⁴—Abrasive cloth, silicon carbide or aluminum oxide, 100 grit.

7.4 *Pipette*—3 mL to 30 mL capacity, dependent on the amount of water required for a ratio of 10 to 1 test sample to water.

7.5 *Graduated cylinder*—50 mL to 300 mL capacity, dependent on the test apparatus, with divisions of 5 % or better of the

total volume. For example, 50 mL sample volume should be measured using a graduated cylinder with graduations of 2.5 mL or less.

7.6 Steel Test Rods:

7.6.1 The steel test rod, when new, shall be 12.7 mm (0.5 in.) in diameter and approximately 68 mm (2 1/16 in.) in length exclusive of the threaded portion that screws into the PTFE holder and shall be tapered at one end as shown in Fig. 2.

7.6.2 The steel test rods shall be made of steel conforming to UNS Grade G10180 (AISI 1018) per Specification A108 (chemistry listed in Specification A29/A29M).

7.6.3 Discard reused rods when the diameter is reduced to 9.5 mm (0.375 in.).

7.7 *PTFE holders for steel test rods*—The PTFE holder screws onto the threaded end of the steel test rod.

8. Hazards

8.1 *Physical*—Care should be taken when manually polishing the steel test rods to avoid injury to hands. This test method also uses aggressive organic solvents; safety glasses should be worn at all times.

8.2 *Chemical*—Flammable, toxic and corrosive chemicals are used in this test procedure. It is the responsibility of the user to follow appropriate handling and storage procedures.

8.2.1 The test shall be run in a well-ventilated space or in a fume hood to avoid build up and exposure to fuel vapors. Test jar covers and secondary spill containers (water bath) are used to reduce the concentration of vapors and contain fuel spills.

9. Standard Preparation

9.1 Standards 1, 2, 3, 4 and 5 in Table 1 shall be prepared and tested when the test method is initially set-up in the laboratory or to demonstrate equivalency of test equipment.

9.2 It is required that one or more of the standards be prepared and tested in the following instances:

9.2.1 When new steel test rods are received.

9.2.2 When new operators are being trained on this procedure.

9.3 Testing of the standards in Table 1 provide the operator and individual laboratory with visual examples of the rating scale.

9.4 Standards are prepared by mixing 84 volume % reagent alcohol, 15 volume % Fuel C and 1 volume % water containing various concentrations of sodium chloride, formic acid and acetic acid. The final concentrations of chloride ion, formic

³ *Reagent Chemicals, American Chemical Society Specifications*, American Chemical Society, Washington, DC. For suggestions on the testing of reagents not listed by the American Chemical Society, see *Analar Standards for Laboratory Chemicals*, BDH Ltd., Poole, Dorset, U.K., and the United States *Pharmacopeia and National Formulary*, U.S. Pharmacopeial Convention, Inc. (USPC), Rockville, MD.

⁴ The sole source of supply of the abrasive cloth known to the committee at this time is available as Part No. 8230A76 from McMaster-Carr Supply Co., PO Box 4355, Chicago, IL, 60680-4355. If you are aware of alternative suppliers, please provide this information to ASTM International Headquarters. Your comments will receive careful consideration at a meeting of the responsible technical committee,¹ which you may attend.