



Designation: ~~D5485 – 11~~ D5485 – 16

Standard Test Method for Determining the Corrosive Effect of Combustion Products Using the Cone Corrosimeter¹

This standard is issued under the fixed designation D5485; the number immediately following the designation indicates the year of original adoption or, in the case of revision, the year of last revision. A number in parentheses indicates the year of last reapproval. A superscript epsilon (ϵ) indicates an editorial change since the last revision or reapproval.

1. Scope*

1.1 This fire-test-response standard measures the corrosive effect by loss of metal from the combustion products of materials, components, or products.

1.2 This test method provides corrosion results of product and material specimens limited to a maximum size of 100 by 100 mm in area and 50 mm thick.

1.3 Additional information regarding the targets, the test conditions, and test limitations is provided in the annex.

1.4 The results of this test method have not been investigated with respect to correlation to actual fires.

1.5 An ISO standard exists, as developed by ISO TC 61 (Plastics), subcommittee 4 (on burning behavior), which is technically very similar to this test method and is designated ISO 11907-4.

1.6 The values stated in SI units are to be regarded as standard. No other units of measurement are included in this standard. (See [SI10](#))

1.7 *This standard measures and describes the response of materials, products, or assemblies to heat and flame under controlled conditions, but does not by itself incorporate all factors required for fire hazard or fire risk assessment of the materials, products, or assemblies under actual fire conditions.*

1.5.1 Additional information regarding the targets, the test conditions, and test limitations are provided in the annex.

1.8 *Fire testing is inherently hazardous. Adequate safeguards for personnel and property shall be employed in conducting these tests.*

1.9 *This standard does not purport to address all of the safety concerns, if any, associated with its use. It is the responsibility of the user of this standard to establish appropriate safety and health practices and determine the applicability of regulatory limitations prior to use.* For specific hazard statements, see Section 7.

2. Referenced Documents

2.1 *ASTM Standards:*²

[D618 Practice for Conditioning Plastics for Testing](#)

[D1711 Terminology Relating to Electrical Insulation](#)

[D6113 Test Method for Using a Cone Calorimeter to Determine Fire-Test-Response Characteristics of Insulating Materials Contained in Electrical or Optical Fiber Cables](#)

[E176 Terminology of Fire Standards](#)

[E1354 Test Method for Heat and Visible Smoke Release Rates for Materials and Products Using an Oxygen Consumption Calorimeter](#)

[IEEE/ASTM SI-10 Standard for Use of the International System of Units \(SI\): The Modern Metric System](#)

2.2 *ISO Standards*³

[ISO 11907-4 Plastics—Smoke Generation—Determination of the Corrosivity of Fire Effluents—Part 4: Dynamic Decomposition Method Using a Conical Radiant Heater](#)

¹ This test method is under the jurisdiction of ASTM Committee [D09](#) on Electrical and Electronic Insulating Materials and is the direct responsibility of Subcommittee [D09.17](#) on Fire and Thermal Properties.

Current edition approved April 1, 2011; November 1, 2016. Published April 2011; November 2016. Originally approved in 1994. Last previous edition approved in 2011 as [D5485 – 10](#); [D5485 – 11](#). DOI: [10.1520/D5485-11.1520/D5485-16](#).

² For referenced ASTM standards, visit the ASTM website, [www.astm.org](#), or contact ASTM Customer Service at [service@astm.org](#). For *Annual Book of ASTM Standards* volume information, refer to the standard's Document Summary page on the ASTM website.

³ Available from International Organization for Standardization (ISO), 1, ch. de la Voie-Creuse, Case postale 56, CH-1211, Geneva 20, Switzerland, [http://www.iso.ch](#).

*A Summary of Changes section appears at the end of this standard

2.3 Other Document:

OSHA 191.1450 Occupational Exposure to Hazard Chemicals in Laboratories⁴

3. Terminology

3.1 Definitions:

3.1.1 For definitions of terms used in this test method, refer to Terminologies **E176** and **D1711**.

3.2 Definitions of Terms Specific to This Standard:

3.2.1 *cone corrosimeter, n*—equipment used to determine corrosion in this test method.

3.2.2 *corrosion-by-metal-loss, n*—loss of metal of a target expressed as reduction of thickness of the target metal.

3.2.3 *exposure chamber, n*—enclosure in which a target is exposed to combustion products.

3.2.4 *heating flux, n*—incident power per unit area that is imposed externally from the heater on the specimen.

⁴ Available from Occupational Safety and Health Administration (OSHA)/U.S. Department of Labor, 200 Constitution Ave., NW, Washington, DC 20210, <http://www.osha.gov>.

3.2.4.1 Discussion—

The specimen, once ignited, is also heated by its own flame.

3.2.5 *sustained flaming, n*—existence of flame on or over the surface of the test specimen for periods of 4 s or more.

3.2.5.1 Discussion—

Flaming ignition of less than 4 s is identified as transitory flaming or flashing.

3.2.6 *target, n*—detector of known electrical resistance which can lose metal through a process of corrosion when it is exposed to combustion products.

3.3 Symbols Specific to This Standard:

3.3.1 A_0 —initial corrosion instrument reading.

3.3.2 A_1 —corrosion instrument reading at the end of 1-h exposure to combustion products.

3.3.3 A_{24} —corrosion instrument reading at the end of 24 h in the environmental chamber.

3.3.4 C —corrosion of a target, nm.

3.3.5 C_1 —corrosion at the end of 1-h exposure to combustion products, nm.

3.3.6 C_{24} —corrosion at the end of 24 h in the environmental chamber, nm.

3.3.7 m —specimen mass, g.

3.3.8 m_f —final specimen mass, g.

3.3.9 m_i —initial specimen mass, g.

3.3.10 m_{70} —average 70 % of the total mass loss, g.

3.3.11 t_d —sampling time, s.

3.3.12 T_e —temperature of the gas in the exposure chamber, °C.

3.3.13 V —volumetric sampling rate of combustion products, m³/s.

4. Summary of Test Method

4.1 In this test method, a specimen is subjected to radiant heat. A spark igniter is used to ignite the combustible vapors. The products of decomposition or combustion are channeled through a funnel. A portion of the products continuously flows through an exposure chamber which holds the corrosion targets until the specimen has lost an average 70 % of the total combustible mass or for a period of 60 min, whichever is less. The corrosion of the target is determined by exposure of the target to combustion products for 1 h, followed by 24-h exposure of the target to a controlled humidity and temperature environment in a separate chamber. The increase in electrical resistance of each target is monitored, and the reduction in thickness of the metal on the target is calculated from the increase in electrical resistance. This reduction in thickness is referred to as corrosion-by-metal-loss.

4.2 This test method involves the use of a cone corrosimeter as described in Section 7 and shown in Fig. 1.

4.3 Alternate equipment found suitable for this test method is the cone calorimeter (see Test Method **E1354**), with the addition of the gas sampling system described in this test method.

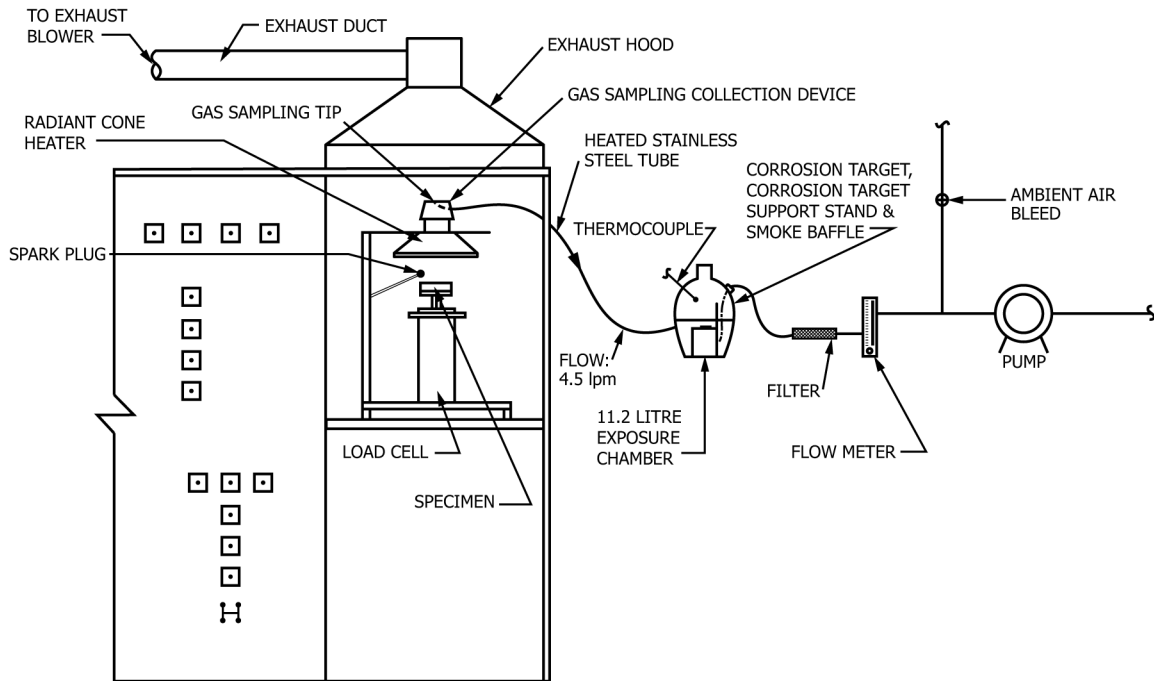

FIG. 1 Cone Corrosimeter

5. Significance and Use

5.1 The metal loss from corrosion is directly related to the increase in electrical resistance of the target due to the decrease in conductive cross-sectional area.

5.2 The relationship between resistance increase of metallic targets used in this test method and the amount of metal loss as reported by a uniform loss in thickness has not been determined.

5.3 This test method is used to determine the corrosive effect of combustion products from burning electrical insulations or coverings or their constituent materials or components. Corrosion is determined by the reduction of thickness of the metal on standardized targets, as measured by electrical resistance. These targets are not necessarily representative of the intended end use.

5.4 This test method is intended for use in electrical insulations or coverings material and product evaluations, for additional data to assist in design of electrical insulations or coverings products, or for development and research of electrical insulations or coverings products.

5.5 A value of the heating flux is selected to be relevant to the fire scenario being investigated (up to 100 kW/m²). Additional information for testing is given in A1.2.3.

6. Interferences

6.1 Discard the test data if any of the following occur:

6.1.1 Leakage occurs between the sampling point and the exit of the exposure chamber which could cause a dilution of gases.
 6.1.2 The specimen swells sufficiently prior to ignition to touch the spark plug or swells into the plane of the heater base plate during combustion.

6.1.3 The specimen drips off the specimen holder or falls out of the specimen holder such that the specimen is not subjected to the test exposure conditions.

6.1.4 There is highly localized corrosion of the target, indicating a defective target.

6.1.5 There is visual degradation of the reference circuit by the attack of combustion products on or under the protective coating.

7. Apparatus

7.1 General:

7.1.1 This test method uses the cone corrosimeter described in 7.1.3. Alternatively, the cone calorimeter test equipment is acceptable provided that it is equipped with a gas sampling system as described in 7.8. If the cone calorimeter is used to assess the fire properties of insulating materials contained in electrical or optical fiber cables, the test shall be conducted in accordance with Test Method D6113, which was developed specifically for that purpose.

7.1.2 The dimensions of the cone corrosimeter specimen holder and additional equipment used in collection of gas samples are given in Figs. 1-11 and also stated in the following description.

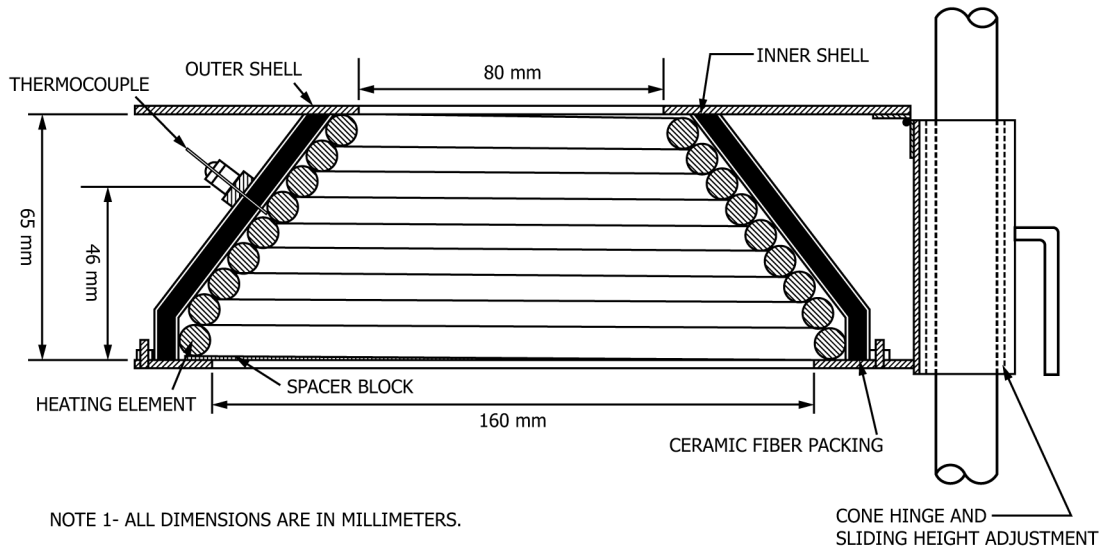

FIG. 2 Cross-Section View Through the Heater

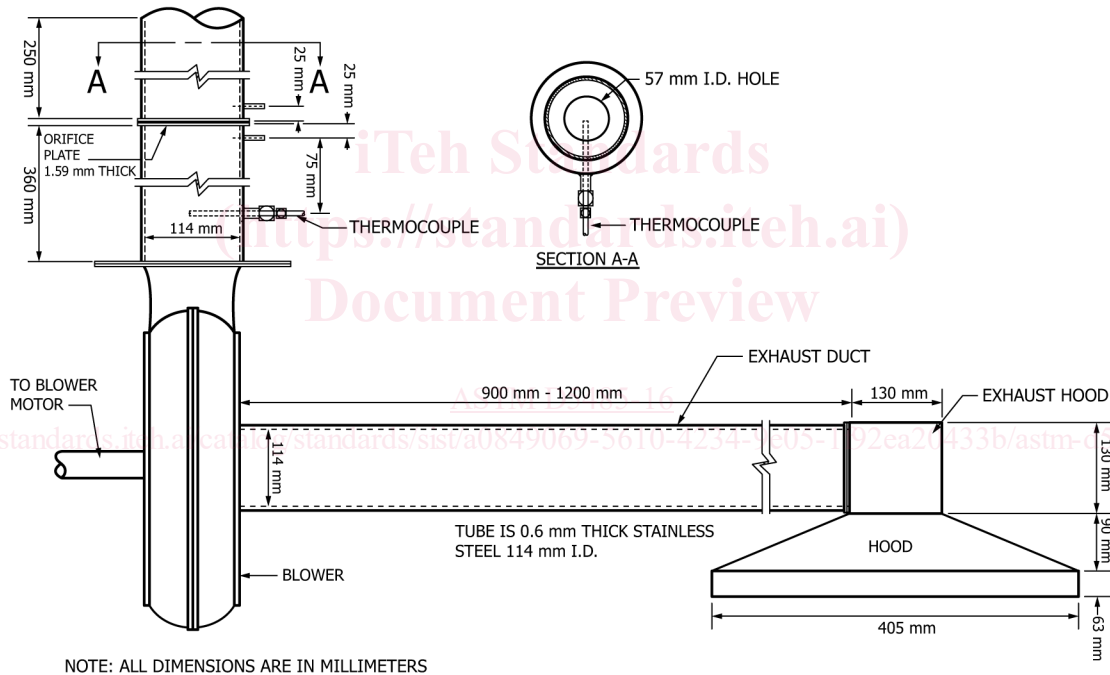

FIG. 3 Exhaust System

7.1.3 The cone corrosimeter consists of the following main components: conical-shaped radiant electric heater; temperature controller; load cell; electric ignition spark plug; heat-flux gage; exhaust system; specimen holder; and the gas sampling system. Other essential elements needed to measure corrosion are a corrosion target and a device to measure corrosion (see 7.9). A general view of the cone corrosimeter is shown in Fig. 1.

7.2 Conical Heater:

7.2.1 The active element of the heater consists of an electrical heater rod, rated at 5000 W at 240 V, tightly wound into the shape of a truncated cone (Fig. 2). The heater is encased on the outside with a double-wall stainless steel cone, and packed with a refractory fiber material of approximately 100-kg/m³ density.

7.2.2 The heater is capable of producing heating flux on the surface of the specimen of up to 100 kW/m² with a uniformity of $\pm 2\%$ within the central 50 by 50-mm area of the specimen.

7.2.3 The heating flux from the heater is held at a preset level by means of a temperature controller and three Type K stainless-steel-sheathed thermocouples having an outside diameter of 1.5 to 1.6 mm with an unexposed hot junction. Alternatively, either 3-mm outside diameter sheathed thermocouples with an exposed hot junction, or 1-mm outside diameter sheathed

LOAD CELL AND CONE RADIANT HEATER

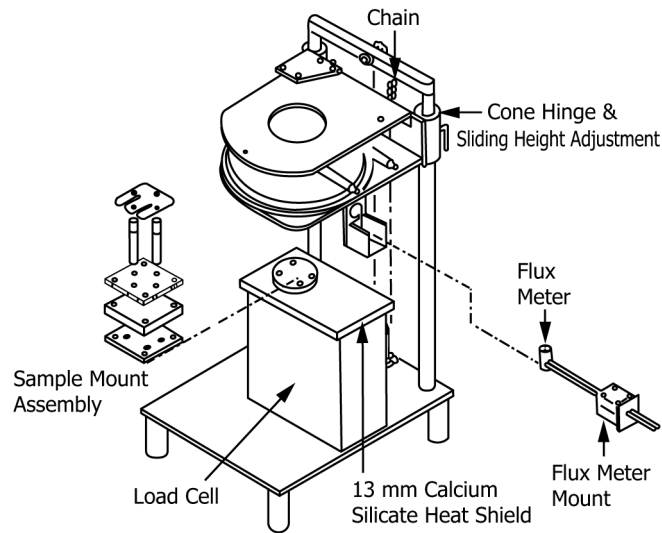

FIG. 4 Exploded View of Load Cell and Cone Radiant Heater

thermocouples with an unexposed hot junction are suitable. They are symmetrically disposed and in contact with, but not welded to, the heater element (see Fig. 2). The thermocouples are of equal length and wired in parallel to the temperature controller.

7.3 Temperature Controller:

7.3.1 The temperature controller for the heater is to hold the element temperature steady to within $\pm 2^\circ\text{C}$. A suitable temperature controller system is a “3-term” controller (proportional, integral, and derivative) with a thyristor unit capable of switching currents up to 25 A at 240 V.

7.3.2 The controller has a temperature input range from 0 to 1000°C; a set scale with a resolution of 2°C; and automatic cold junction compensation. The controller is equipped with a safety feature such that in the event of an open circuit in the thermocouple line, it will cause the temperature to fall to near the bottom of its range.

7.3.3 The temperature controller uses a zero-crossing-type thyristor unit.

7.3.4 The heater temperature is monitored by a meter with a resolution of 2°C.

7.4 Exhaust System:

7.4.1 The exhaust-gas system consists of a high-temperature centrifugal exhaust blower, a hood, intake and exhaust ducts for the fan, and an orifice plate flowmeter (Fig. 3).

7.4.2 The flow rate is determined by measuring the differential pressure across a sharp-edged orifice (57-mm inside diameter) in the exhaust stack, at least 350 mm downstream from the fan.

7.4.3 In other details, the geometry of the exhaust system is not critical. Where necessary, small deviations from the recommended dimensions given in Fig. 3 are allowed. For example, it is permissible for the inner diameter of the duct and the orifice plate to be slightly different (tolerance: ± 2 mm). The location of the fan in Fig. 3 shall be between 900 and 1200 mm downstream of the hood. Flow through the fan ensures adequate mixing, which is essential to the test.

7.5 **Load Cell**—The general arrangement of the load cell with the conical heater is shown in Fig. 4. Use a load cell with an accuracy of 0.1 g, a measuring range of at least 500 g, and a mechanical tare adjustment range of 3.5 kg.

7.6 Specimen Holder and Mounting:

7.6.1 Two specimen holders are described, one in 7.6.2 – 7.6.4 and one in 7.6.5.

7.6.2 The first specimen holder is shown in Fig. 5. The bottom is constructed from 2.4-mm nominal stainless steel and has outside dimensions of 106 by 106 by 25-mm height (± 2 mm).

7.6.2.1 An open stainless steel square, 59 mm in inside dimensions, shall be spot welded to the underside of the horizontal specimen holder to facilitate the centering of the specimen under the cone heater. The leading edge of the open square underneath the specimen holder, which is the one opposite the handle, is optional. The open square on the bottom of the specimen holder shall be designed to seat with the sample mount assembly located at the top of the load cell, ensuring that the specimen holder is centered with respect to the cone heater.

7.6.2.2 Optionally, use an edge frame and a grid. The optional edge frame (Fig. 6) is constructed from 1.9-mm nominal stainless steel with outside dimensions of 111 by 111 by 54-mm height (± 2 mm). The optional grid (Fig. 7) is constructed from 1-mm nominal stainless steel and has dimensions of 109 by 109 mm (± 2 mm). The optional grid has 2-mm ribs and the openings in the center are 20 by 20 mm (± 1 mm).

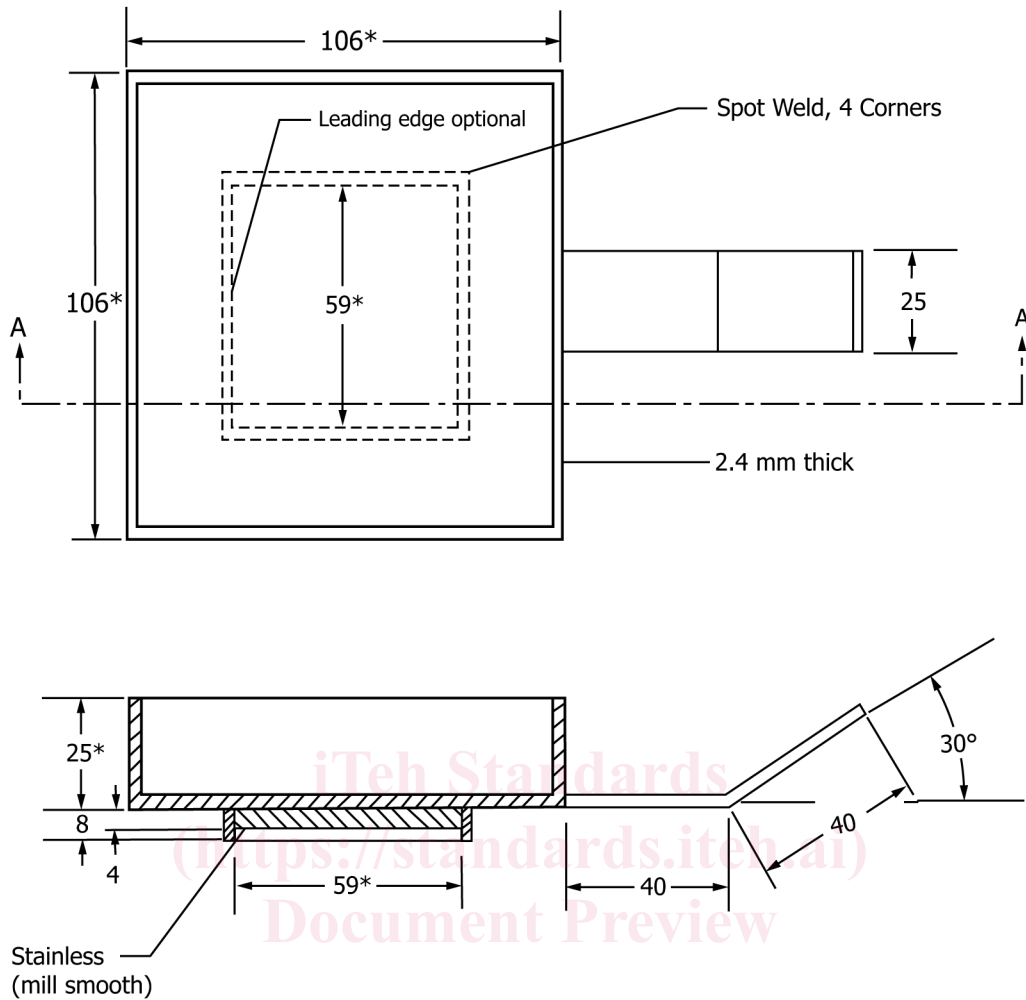

Section A-A

NOTE 1—All dimensions are in millimetres.
 NOTE 2—* Indicates a critical dimension.

FIG. 5 First Specimen Holder

7.6.3 The distance between the bottom surface of the cone heater and the top of the specimen shall be adjusted to be 25 ± 1 mm (Fig. 2), except as indicated in 7.6.3.1.

7.6.3.1 The distance between the bottom surface of the cone heater and the top of the specimen shall be adjusted to 60 mm in the case of those dimensionally unstable materials that have the potential to intumesce or deform to such an extent that they are likely to make physical contact with either (a) the spark plug before ignition or (b) the underside of the cone heater after ignition.

7.6.3.2 If a test is conducted in accordance with the specimen mounting in 7.6.3.1 (a 60 mm distance), the heat flux calibration shall be performed with the heat flux meter positioned 60 mm below the cone heater base plate.

7.6.3.3 If a test has been conducted with a distance of 25 mm and the type of physical contact described in 7.6.3.1 has occurred, that test shall be deemed invalid and the distance shall be adjusted to 60 mm for future tests.

7.6.4 Intumescent materials. The testing technique to be used when testing intumescent specimens in the horizontal orientation shall be documented in the test report. Options include those shown in 7.6.4.1 – 7.6.4.4.

7.6.4.1 Use a retainer frame or edge frame (Fig. 6). The edge frame is used to reduce unrepresentative edge burning of specimens. The edge frame is constructed from 1.9-mm nominal stainless steel with outside dimensions of 111 by 111 by 54-mm height (± 2 mm).

7.6.4.2 Use a wire grid (Fig. 7). The wire grid is used for retaining specimens prone to delamination and is suitable for several types of intumescent specimens. The grid is constructed from 1-mm nominal stainless steel and has dimensions of 109 by 109 mm (± 2 mm). The grid has 2-mm ribs and the openings in the center are 20 by 20 mm (± 1 mm).

7.6.4.3 Use a separation distance between the cone base plate and the upper specimen surface of 60 mm instead of 25 mm. This technique is suitable for those dimensionally unstable materials that have the potential to intumesce or deform to such an extent that they are likely to make physical contact with either (a) the spark plug before ignition or (b) the underside of the cone heater after ignition.