



Designation: **D6097 – 01a (Reapproved 2008)<sup>ε1</sup> D6097 – 16**

# Standard Test Method for Relative Resistance to Vented Water-Tree Growth in Solid Dielectric Insulating Materials<sup>1</sup>

This standard is issued under the fixed designation D6097; the number immediately following the designation indicates the year of original adoption or, in the case of revision, the year of last revision. A number in parentheses indicates the year of last reapproval. A superscript epsilon ( $\epsilon$ ) indicates an editorial change since the last revision or reapproval.

---

<sup>ε1</sup> NOTE—The units statement in subsection 1.2 was corrected and the warning in old Note 2 was moved into the text of 8.2 editorially in July 2008.

---

## 1. Scope

1.1 This test method covers the relative resistance to vented water-tree growth in solid translucent thermoplastic or cross-linked electrical insulating materials. This test method is especially applicable to extruded polymeric insulation materials used in medium-voltage cables.

1.2 The values stated in SI units are to be regarded as standard. No other units of measurement are included in this standard.

1.3 *This standard does not purport to address all of the safety concerns, if any, associated with its use. It is the responsibility of the user of this standard to establish appropriate safety and health practices and determine the applicability of regulatory limitation prior to use.* For specific hazard statements see 8.1.

1.4 There is no similar or equivalent IEC standard.

## 2. Referenced Documents

2.1 *ASTM Standards:*<sup>2</sup>

[D1711 Terminology Relating to Electrical Insulation](#)

[D1898 Practice for Sampling of Plastics \(Withdrawn 1998\)](#)<sup>3</sup>

[D1928 Practice for Preparation of Compression-Molded Polyethylene Test Sheets and Test Specimens \(Withdrawn 2001\)](#)<sup>3</sup>

[D2275 Test Method for Voltage Endurance of Solid Electrical Insulating Materials Subjected to Partial Discharges \(Corona\) on the Surface](#)

[D3756 Test Method for Evaluation of Resistance to Electrical Breakdown by Treeing in Solid Dielectric Materials Using Diverging Fields](#)

## 3. Terminology

### 3.1 Definitions:

3.1.1 Use Terminology [D1711](#) for definitions of terms used in this test method and associated with electrical insulation materials.

### 3.2 Definitions of Terms Specific to This Standard:

3.2.1 *water tree length (WTL), n*—the maximum length of a stained tree-like micro-channel path in ~~millimetres~~millimeters, measured from the tip of the conical defect in the direction of the conical axis.

3.2.2 *resistance to water-tree growth (RWFG)—(RWFG), n*—a dimensionless value which is  $L$  divided by the WTL.

3.2.3 *thickness of point-to-plane specimen (L), n*—the vertical distance in ~~millimetres~~millimeters from the tip of the conical defect to the opposite surface of the solid dielectric material.

3.2.4 *semiconductive shield, n*—polymer/carbon black composite material used in medium voltage cables with volume resistivity between  $10^4$  and  $10^5$  ohm-cm.

<sup>1</sup> This test method is under the jurisdiction of ASTM Committee D09 on Electrical and Electronic Insulating Materials and is the direct responsibility of Subcommittee D09.12 on Electrical Tests.

Current edition approved May 1, 2008; Nov. 1, 2016. Published July 2008; December 2016. Originally approved in 1997. Last previous edition approved in 2004 as ~~D6097 – 01a~~D6097 – 01a (2008)<sup>ε1</sup>. DOI: ~~10.1520/D6097-01A~~10.1520/D6097-16.

<sup>2</sup> For referenced ASTM standards, visit the ASTM website, [www.astm.org](http://www.astm.org), or contact ASTM Customer Service at [service@astm.org](mailto:service@astm.org). For *Annual Book of ASTM Standards* volume information, refer to the standard's Document Summary page on the ASTM website.

<sup>3</sup> The last approved version of this historical standard is referenced on [www.astm.org](http://www.astm.org).

4. Summary of Test Method

4.1 Ten compression-molded disk specimens, each containing a conical-shaped defect, are subjected to an applied voltage of 5 kV at 1 kHz and  $23 \pm 2^\circ\text{C}$  in an aqueous conductive solution of 1.0 N NaCl-sodium chloride (NaCl) for 30 days. This controlled conical defect is created by a sharp needle with an included angle of  $60^\circ$  and a tip radius of  $3 \mu\text{m}$ . The electrical stress at the defect tip is enhanced and ~~can be is~~ estimated by the Mason’s Hyperbolic point-to-plane stress enhancement equation.<sup>4</sup> This enhanced electrical stress initiates the formation of a vented water-tree grown from the defect tip. Each treed specimen is stained and sliced. The water-tree length and point-to-plane specimen thickness measured under microscope are used to calculate a ratio that is defined as the resistance to water-tree growth.

5. Significance and Use

5.1 This is a laboratory test designed to simulate the growth of vented water-trees in the solid dielectric insulating material initiated by a sharp protrusion at the insulating and conductive interface under a wet environment in a high electrical field. Water-treing is the phenomenon which describes the appearance of tree-like growth in organic dielectrics under an ac field when exposed to moist environments. Two types of water-trees are formed. Bow tie trees (within the dielectric) and vented water-trees formed from conductive/insulating material interface into the insulating material. The water-trees referred to in this test method are the vented type. The insulating material is the solid dielectric organic material. The conductive material is the salt solution. This salt solution is used on both sides of the insulating material to simulate the same inner and outer semiconductive shields saturated with moisture between the insulation layer used in a medium-voltage underground power cable.

5.2 This test method provides comparative data. The degree of correlation with the performance in service has not been established.

5.3 The standard test conditions are designed to grow a sufficient water-tree length for most solid dielectric insulating materials of interest before electrical breakdown occurs. Materials with a very high resistance to water-tree growth may require a longer time under test conditions (such as 180 days) or higher voltage (such as 10 or 15 kV) in order to differentiate their performance. For

<sup>4</sup> The sole source of supply of the base, Dow Corning 3110RTV, the catalyst, Dow Corning RTV Catalyst S, and the sealant, Dow Corning Multipurpose Silicone Sealant 732, known to the committee at this time is Dow Corning, Inc., Midland, MI 48686. If you are aware of alternative suppliers, please provide this information to ASTM International Headquarters. Your comments will receive careful consideration at a meeting of the responsible technical ~~committee,~~ committee, which you may attend.

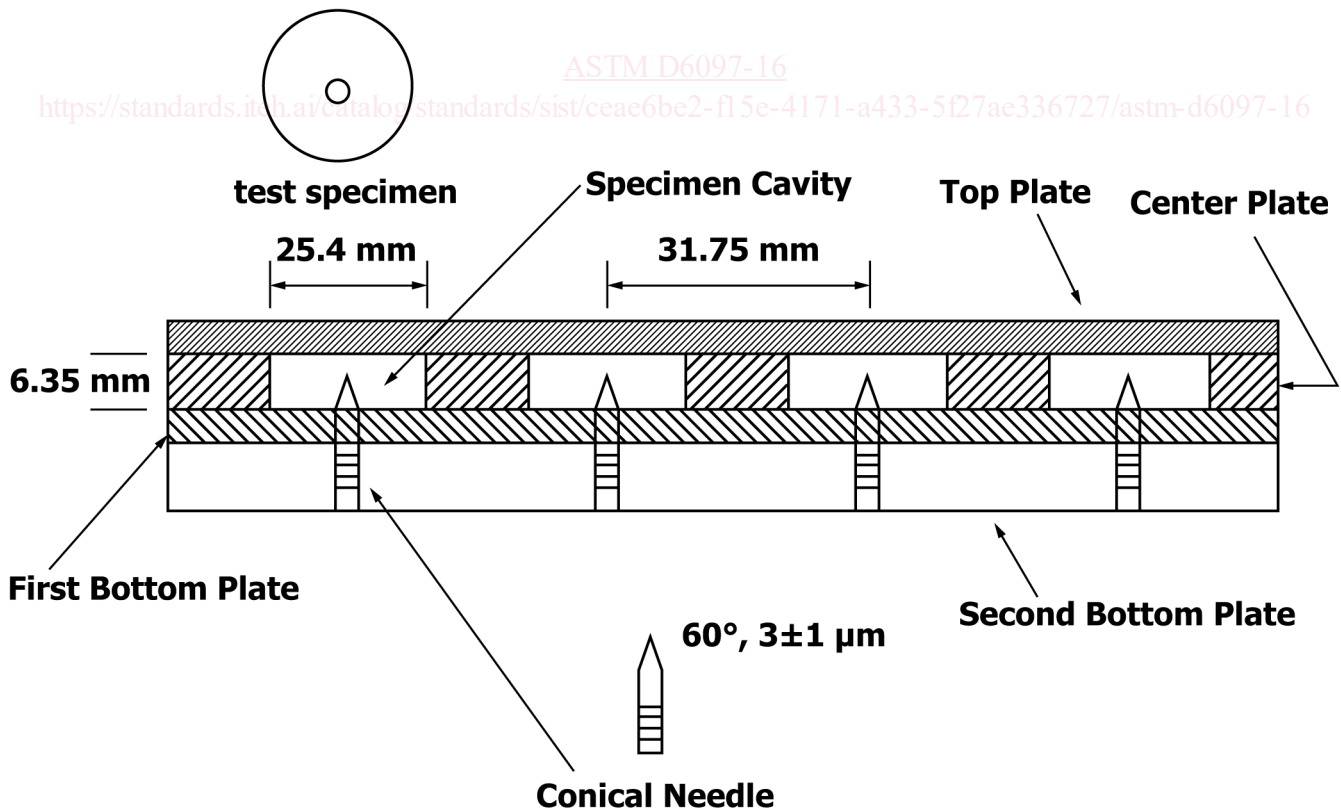

FIG. 1 — Test Specimen Mold Cavity

materials with a very low resistance to water-tree growth, electrical breakdown ~~may~~will occur during the 30-day testing ~~time.~~time in most instances. A shorter testing time (such as one or ten days) is recommended to prevent electrical breakdown during testing for those low water-tree resistant materials.

5.4 Other voltages, frequencies, temperatures, aqueous solutions, and defects ~~can~~are able to be used to evaluate specific materials for specific applications. Temperatures ~~should~~shall not exceed the softening or melting point of the material or 10 to 15°C below the boiling point of the salt solution. Any nonstandard conditions ~~should~~shall be reported along with the results.

5.5 Tree-growth rates generally increase with the test frequency. An acceleration factor due to frequency is given by  $(f/60)^k$  where  $f$  is the test frequency and  $k$  is between 0.6 and 0.7. The test frequency of 1 kHz is selected to accelerate the water-tree growth. However, ~~the~~there is the possibility that the chemical nature of oxidized products from water-treing may be different at different frequency ranges.

5.6 Two assumptions for this test method are: (1) all tested materials grow trees in the same power law kinetic manner and (2) the time under test conditions of 30 days is long enough to establish the difference in water-tree growth. If there is a doubt, at least three different testing times (such as 30, 90, and 180 days) ~~should~~shall be used to verify their comparative performance and disclose their kinetic nature of water-tree growth. Of course, it is also assumed that all water-treed regions are oxidized regions that ~~can~~are able to be stained for optical observation. ~~Different materials may also have different temperatures.~~The softening temperature of different materials will require different temperature and times to stain the oxidized (treed) regions due to their different softening temperature regions.

## 6. Apparatus

6.1 *Power Supply*—A high-voltage supply with a sinusoidal voltage output of at least 5 kV at a frequency of 1 kHz and an output power of 3 kVA.

6.2 *Conical Needles*—Conical needles are made from steel or tungsten carbide. Their dimensions are  $14.5 \pm 0.5$  mm long,  $4 \pm 0.2$  mm in diameter, point radius of  $3 \pm 1$   $\mu$ m for the needle tip radius, and  $60 \pm 1^\circ$  point angle.

6.3 *Test Specimen Mold*—The test specimen mold is a three-layer metal mold. The top metal plate is flat. The center plate has at least ten holes to make ten test specimens for each material. Each hole has a 25.4-mm diameter and at least 31.75-mm spacing from center to center of each hole. The center plate also has the guide holes about 8 mm in diameter at two corners to mate with pins in the bottom plate section. The bottom plate section consists of two metal plates bolted together. The first bottom plate has the same number of holes as the center plate. Each hole has the inside diameter of 4 mm to accommodate needles. The second bottom plate has the holes with an inside diameter of 10 mm. The center points of all the holes in the bottom and center plates are matched and aligned. These holes at the second bottom plate are threaded to accommodate the needle support member. The needle support member is fabricated from threaded stainless steel rod drilled at one end to provide a snug fit for needles, and at the other end to accommodate an hexagonal head driver. Needles are threaded into the support member. The needle and needle support assembly is carefully screwed into the base until the needle point extends  $3.2 \pm 0.1$  mm above the surface. **Fig. 1** is an example of the mold cavity.

6.4 *Specimen Holder*—The specimen holder, designed to hold at least ten specimens, is made from a solid block of clear polymethyl methacrylate (PMMA). The PMMA is used because of the ease of machining and its good electrical properties. The inside is machined to a depth of 50.8 mm with a 12.7-mm wall thickness. The outside bottom has the same number of holes with an inside diameter of 25.4 mm with a depth of ~~6.35 mm~~, 6.35 mm, drilled with a spacing of 38.1 mm from center to center of the holes. The inside bottom has the same holes with an inside diameter of 12.7 mm and a depth of ~~6.35 mm~~ 6.35 mm in line with the centers of the holes drilled at the outside bottom. **Fig. 2** is an example of the specimen holder.

6.5 *Electrodes*—The electrode is made from a 1-m length of 24 AWG nickel-chromium wire or other suitable conductive, noncorrosive metal wire formed, on one end, into a closed loop about 50 mm smaller in diameter than the inside diameter of the specimen holder with the remainder bent perpendicular to the loop so that it ~~can be~~is able to connected to the transformer to conduct the voltage into the electrolyte (the salt solution).

6.6 *Water Bath*—A circulating water bath; provided with heaters and temperature controls if tests are to be made at elevated temperatures.

NOTE 1—Circulation of the solution in the bath even at room temperature is necessary to remove gas bubbles formed at the interface of the solution and the test specimens caused by electrolysis.

6.7 *Microscope*—A microscope equipped for 20 and 100 $\times$  magnification.

## 7. Reagents

7.1 *Salt*—Reagent-grade sodium chloride.

7.2 *Sealants*—The material used for sealing in this test method is a two-part silicone rubber sealant consisting of a base<sup>4</sup> and a catalyst.<sup>4</sup>

7.3 *Multipurpose Silicone Sealant*—Sealant—One-part silicone<sup>4</sup> rubber sealant.

