



Designation: **D6232—08 D6232 – 16**

Standard Guide for Selection of Sampling Equipment for Waste and Contaminated Media Data Collection Activities¹

This standard is issued under the fixed designation D6232; the number immediately following the designation indicates the year of original adoption or, in the case of revision, the year of last revision. A number in parentheses indicates the year of last reapproval. A superscript epsilon (ϵ) indicates an editorial change since the last revision or reapproval.

1. Scope

1.1 This guide covers criteria which should be considered when selecting sampling equipment for collecting environmental and waste samples for waste management activities. This guide includes a list of equipment that is used and is readily available. Many specialized sampling devices are not specifically included in this guide. However, the factors that should be weighed when choosing any piece of equipment are covered and remain the same for the selection of any piece of equipment. Sampling equipment described in this guide includes automatic samplers, pumps, bailers, tubes, scoops, spoons, shovels, dredges, coring and augering devices. The selection of sampling locations is outside the scope of this guide.

1.1.1 Table 1 lists selected equipment and its applicability to sampling matrices, including water (surface and ground), sediments, soils, liquids, multi-layered liquids, mixed solid-liquid phases, and consolidated and unconsolidated solids. The guide does not address specifically the collection of samples of any suspended materials from flowing rivers or streams. Refer to Guide [D4411](#) for more information.

1.2 Table 2 presents the same list of equipment and its applicability for use based on compatibility of sample and equipment; volume of the sample required; physical requirements such as power, size, and weight; ease of operation and decontamination; and whether it is reusable or disposable.

1.3 Table 3 provides the basis for selection of suitable equipment by the use of an Index.

1.4 Lists of advantages and disadvantages of selected sampling devices and line drawings and narratives describing the operation of sampling devices are also provided.

1.5 The values stated in both inch-pound and SI units are to be regarded separately as the standard units. The values given in parentheses are for information only.

1.6 This guide offers an organized collection of information or a series of options and does not recommend a specific course of action. This document cannot replace education or experience and should be used in conjunction with professional judgement. Not all aspects of this guide may be applicable in all circumstances. This ASTM standard is not intended to represent or replace the standard of care by which the adequacy of a given professional service must be judged, nor should this document be applied without consideration of a project's many unique aspects. The word "Standard" in the title of this document means only that the document has been approved through the ASTM consensus process.

1.7 *This standard does not purport to address all of the safety concerns, if any, associated with its use. It is the responsibility of the user of this standard to establish appropriate safety and health practices and determine the applicability of regulatory limitations prior to use.*

2. Referenced Documents

2.1 *ASTM Standards:*²

[D1452 Practice for Soil Exploration and Sampling by Auger Borings](#)

[D1586 Test Method for Penetration Test \(SPT\) and Split-Barrel Sampling of Soils](#)

[D1587 Practice for Thin-Walled Tube Sampling of Fine-Grained Soils for Geotechnical Purposes](#)

¹ This guide is under the jurisdiction of ASTM Committee [D34](#) on Waste Management and is the direct responsibility of Subcommittee [D34.01.01](#) on Planning for Sampling.

Current edition approved Jan. 1, 2008; Nov. 15, 2016. Published February 2008; December 2016. Originally approved in 1998. Last previous edition approved in 2003 as [D6232—03](#); [D6232—08](#). DOI: [10.1520/D6232-08](#); [10.1520/D6232-16](#).

² For referenced ASTM standards, visit the ASTM website, [www.astm.org](#), or contact ASTM Customer Service at [service@astm.org](#). For *Annual Book of ASTM Standards* volume information, refer to the standard's Document Summary page on the ASTM website.

- D3550 Practice for Thick Wall, Ring-Lined, Split Barrel, Drive Sampling of Soils (Withdrawn 2016)³
- D4136 Practice for Sampling Phytoplankton with Water-Sampling Bottles
- D4342 Practice for Collecting of Benthic Macroinvertebrates with Ponar Grab Sampler (Withdrawn 2003)³
- D4343 Practice for Collecting Benthic Macroinvertebrates with Ekman Grab Sampler (Withdrawn 2003)³
- D4348 Practice for Collecting Benthic Macroinvertebrates with Holme (Scoop) Grab Sampler (Withdrawn 2003)³
- D4387 Guide for Selecting Grab Sampling Devices for Collecting Benthic Macroinvertebrates (Withdrawn 2003)³
- D4411 Guide for Sampling Fluvial Sediment in Motion
- D4448 Guide for Sampling Ground-Water Monitoring Wells
- D4547 Guide for Sampling Waste and Soils for Volatile Organic Compounds
- D4687 Guide for General Planning of Waste Sampling
- D4696 Guide for Pore-Liquid Sampling from the Vadose Zone
- D4700 Guide for Soil Sampling from the Vadose Zone
- D4823 Guide for Core Sampling Submerged, Unconsolidated Sediments
- D5013 Practices for Sampling Wastes from Pipes and Other Point Discharges
- D5079 Practices for Preserving and Transporting Rock Core Samples
- D5088 Practice for Decontamination of Field Equipment Used at Waste Sites
- D5283 Practice for Generation of Environmental Data Related to Waste Management Activities: Quality Assurance and Quality Control Planning and Implementation
- D5314 Guide for Soil Gas Monitoring in the Vadose Zone (Withdrawn 2015)³
- D5358 Practice for Sampling with a Dipper or Pond Sampler
- D5451 Practice for Sampling Using a Trier Sampler
- D5495 Practice for Sampling With a Composite Liquid Waste Sampler (COLIWASA)
- D5633 Practice for Sampling with a Scoop
- D5679 Practice for Sampling Consolidated Solids in Drums or Similar Containers
- D5680 Practice for Sampling Unconsolidated Solids in Drums or Similar Containers
- D5730 Guide for Site Characterization for Environmental Purposes With Emphasis on Soil, Rock, the Vadose Zone and Groundwater (Withdrawn 2013)³
- D5743 Practice for Sampling Single or Multilayered Liquids, With or Without Solids, in Drums or Similar Containers
- D5778 Test Method for Electronic Friction Cone and Piezocone Penetration Testing of Soils
- D5781 Guide for Use of Dual-Wall Reverse-Circulation Drilling for Geoenvironmental Exploration and the Installation of Subsurface Water-Quality Monitoring Devices
- D5782 Guide for Use of Direct Air-Rotary Drilling for Geoenvironmental Exploration and the Installation of Subsurface Water-Quality Monitoring Devices
- D5783 Guide for Use of Direct Rotary Drilling with Water-Based Drilling Fluid for Geoenvironmental Exploration and the Installation of Subsurface Water-Quality Monitoring Devices
- D5784 Guide for Use of Hollow-Stem Augers for Geoenvironmental Exploration and the Installation of Subsurface Water-Quality Monitoring Devices
- D5875 Guide for Use of Cable-Tool Drilling and Sampling Methods for Geoenvironmental Exploration and Installation of Subsurface Water-Quality Monitoring Devices
- D5876 Guide for Use of Direct Rotary Wireline Casing Advancement Drilling Methods for Geoenvironmental Exploration and Installation of Subsurface Water-Quality Monitoring Devices
- D6001 Guide for Direct-Push Groundwater Sampling for Environmental Site Characterization
- D6009 Guide for Sampling Waste Piles
- D6044 Guide for Representative Sampling for Management of Waste and Contaminated Media
- D6051 Guide for Composite Sampling and Field Subsampling for Environmental Waste Management Activities
- D6063 Guide for Sampling of Drums and Similar Containers by Field Personnel
- D6151 Practice for Using Hollow-Stem Augers for Geotechnical Exploration and Soil Sampling
- D6169 Guide for Selection of Soil and Rock Sampling Devices Used With Drill Rigs for Environmental Investigations
- D6282 Guide for Direct Push Soil Sampling for Environmental Site Characterizations
- D6286 Guide for Selection of Drilling Methods for Environmental Site Characterization
- D6418 Practice for Using the Disposable En Core Sampler for Sampling and Storing Soil for Volatile Organic Analysis
- D6538 Guide for Sampling Wastewater With Automatic Samplers
- D6634 Guide for Selection of Purging and Sampling Devices for Groundwater Monitoring Wells
- D6640 Practice for Collection and Handling of Soils Obtained in Core Barrel Samplers for Environmental Investigations
- D6699 Practice for Sampling Liquids Using Bailers
- D6759 Practice for Sampling Liquids Using Grab and Discrete Depth Samplers

³ The last approved version of this historical standard is referenced on www.astm.org.

- D6771 Practice for Low-Flow Purging and Sampling for Wells and Devices Used for Ground-Water Quality Investigations (Withdrawn 2011)³
- D6907 Practice for Sampling Soils and Contaminated Media with Hand-Operated Bucket Augers
- E300 Practice for Sampling Industrial Chemicals
- E1391 Guide for Collection, Storage, Characterization, and Manipulation of Sediments for Toxicological Testing and for Selection of Samplers Used to Collect Benthic Invertebrates

iTeh Standards
(<https://standards.itih.ai>)
Document Preview

[ASTM D6232-16](#)

<https://standards.itih.ai/catalog/standards/sist/792b7565-8a1b-4f57-84fe-30a228e90628/astm-d6232-16>

3. Terminology

3.1 Definitions of Terms Specific to This Standard:

3.1.1 *consolidated, adj*—a compact solid not easily compressed or broken into smaller particles.

3.1.2 *decontamination, n*—the process of removing or reducing to a known level undesirable physical or chemical constituents, or both, from a sampling apparatus to maximize the representativeness of physical or chemical analyses proposed for a given sample.

3.1.3 *data quality objectives (DQOs), n*—qualitative or quantitative statement(s) derived from the DQO process describing the problem(s), the decision rule(s) and the uncertainties of the decision(s) stated in the context of the problem.

3.1.4 *environmental data, n*—defined for use in this document to mean data in support of environmental activities.

3.1.5 *matrix, n*—the principal constituent(s) or phase(s) of a material.

3.1.6 *unconsolidated, adj*—defined for use in this document to mean uncemented or uncompacted material that is easily separated into smaller portions.

3.1.7 *representative sample, n*—a sample collected in such a manner that it reflects one or more characteristics of interest (as defined by the project objectives) of a population from which it was collected. **(D6044)**

4. Summary of Guide

4.1 This guide discusses important criteria which should be considered when choosing sampling equipment.

4.1.1 Criteria discussed in this document include physical and chemical compatibility, sample matrix, sample volume, physical requirements, ease of operation and decontamination. Costs are considered, where appropriate.

4.2 A limited list of sampling equipment is presented in two separate tables. The list attempts to include a variety of different types of equipment. However, this list is in no way all inclusive, as there are many excellent pieces of equipment not included. **Table 1** lists matrices (surface and ground water, stationary sediment, soil and mixed phase wastes) and indicates which sampling devices are appropriate for use with these matrices. It also includes ASTM method references (draft standards are not included). **Table 2** indicates physical requirements (such as battery), electrical power, and weight; physical and chemical compatibility; effect on matrix; range of volume; ease of operation; decontamination; and reusability. **Table 3** provides sampler type selection process based upon the sample type and matrix to be sampled.

5. Significance and Use

5.1 Although many technical papers address topics important to efficient and accurate sampling investigations (DQO's, study design, QA/QC, data assessment; see Guides **D4687**, **D5730**, **D6009**, **D6051**, and Practice **D5283**), the selection and use of appropriate sampling equipment is assumed or omitted.

5.2 The choice of sampling equipment can be crucial to the task of collecting a sample appropriate for the intended use.

5.3 When a sample is collected, all sources of potential bias should be considered, not only in the selection and use of the sampling device, but also in the interpretation and use of the data generated. Some major considerations in the selection of sampling equipment for the collection of a sample are listed below.

5.3.1 The ability to access and extract from every relevant location in the target population,

5.3.2 The ability to collect a sufficient mass of sample such that the distribution of particle sizes in the population are represented, and

5.3.3 The ability to collect a sample without the addition or loss of constituents of interest.

5.4 The characteristics discussed in **5.3** are particularly important in investigations when the target population is heterogeneous such as when particle sizes vary, liquids are present in distinct phases, a gaseous phase exists or material from different sources are present in the population. The consideration of these characteristics during the equipment selection process will enable the data user to make appropriate statistical inferences about the target population based on the sampling results.

6. Selection Criteria

6.1 Refer to **Tables 1 and 2** for a summary of matrix compatibility and selection criteria. Refer to **Table 3** for an index of sampling equipment based upon sample type and matrix to be sampled.

6.2 *Compatibility*—It is important that sampling equipment, other equipment which may come in contact with samples (such as gloves, mixing pans, knives, spatulas, spoons, etc.) and sample containers be constructed of materials that are compatible with the matrices and analytes of interest. Incompatibility may result in the contamination of the sample and the degradation of the sampling equipment. Appropriate sampling equipment must be compatible chemically and physically.

6.2.1 *Chemical Compatibility*—The effects of a matrix on the sampling equipment is usually considered in the light of the analytes, or groups of analytes of interest. For example, poly vinyl chloride (PVC) has been found to degrade in the presence of many separate phase organic compounds in water; therefore, it would be preferable to collect ground water samples for organic

TABLE 1 Equipment Selection—Matrix Guide

Equipment (May be used for discrete sample collection)	Water and Waste Water			Sediment	Soil	Waste				
	Surface Water	Ground Water	Point Discharge			Liquid	Multi-Layer Liquid	Mixed Phase Solid/Liquid	Consolidated Solid	Unconsolidated Solid
Pumps and Siphons										
Automatic Sampler—Non volatiles	√D6538 ^G	√D6538 ^G	-	-	N	N	N	-	-	-
Automatic Composite Sampler—Volatiles	√		√	-	-	-	-	-	-	-
Air/Gas Displacement Pump		√D4448 ^G	√	-	-	-	√	-	-	-
Piston Displacement Pump		√D4448 ^G	√	-	-	-	N	-	-	-
Bladder Pumps		√D4448 ^G	√	-	-	N	N	-	-	-
		D6771 ^P	-	-	-	-	-	-	-	-
Peristaltic Pump	√	√D4448 ^G	√	-	-	√	√	N	-	-
Centrifugal Submersible Pump	√	√D4448 ^G	√	-	-	N	N	-	-	-
Gear Drive Pump	√	√D6634 ^G	√	-	-	N	N	-	-	-
Progressing Cavity Pump	√	√D6634 ^G	√	-	-	N	N	-	-	-
Inertia Lift Pump	-	√D4448 ^G	-	-	-	-	-	-	-	-
Dredges										
Ekman Dredge	-	-	-	√D4387 ^G	-	-	-	-	-	-
				D4343 ^P						
Petersen Dredge	-	-	-	√D4387 ^G	-	-	-	-	-	-
Ponar Dredge	-	-	-	√D4387 ^G	-	-	-	-	-	-
				D4342 ^P						
Discrete Depth Samplers										
Bacon Bomb	√D6759 ^P	-	-	-	-	√D6759 ^P	N	-	-	-
Kemmerer Sampler	√D4136 ^P	-	-	-	-	√D6759 ^P	N	-	-	-
	D6759 ^P	-	-	-	-	-	-	-	-	-
Syringe Sampler	√D5743 ^G	-	N	-	-	√D6759 ^P	√D6759 ^P	√D6759 ^P	-	-
	D6759 ^P	-	-	-	-	-	-	-	-	-
Peristaltic Pump	√D6759 ^P	√D4448 ^G	√D6759 ^P	-	-	√D6759 ^P	√D6759 ^P	N	-	-
Lidded Sludge/Water Sampler	-	-	-	-	-	N	N	√D6759 ^P	-	N
Discrete Level Sampler	√D6759 ^P	√	√D6759 ^P	-	-	√D6759 ^P	√D6759 ^P	-	-	-
HYDRASleeve	N	√D4448 ^G	-	-	-	N	N	-	-	-
Snap Sampler	-	√D4448 ^G	-	-	-	N	N	-	-	-
Drive Push Samplers										
Direct Push Water Sampler	-	√	-	-	-	N	-	-	-	-
Probe Sampler, Hand Use	-	-	-	N	√	-	-	N	-	√
Probe Sampler, Rig Use	-	-	-	√D4823 ^G	√	√	√	N	-	N
Split Barrel Sampler	-	-	-	√	√D1586 TM	-	-	N	-	N
					√D4700 ^G					
Continuous Core Sampler	-	-	-	√	√D5784 ^G	-	-	√	-	N
Thin Walled Tube	-	-	-	√D4823 ^G	√D1587 ^P	-	-	-	-	√
					D4700 ^G					
Coring Type w/Valve (Hand Use)	-	-	-	N	√D4823 ^G	-	-	√	-	√
Concentric Tube Thief (Hand Use)	-	-	-	-	-	-	-	-	-	√
Trier (Hand Use)	-	-	-	-	√	-	-	N	-	√D5451 ^P
										√E300 ^P
Miniature Core Sampler (Hand Use)	-	-	-	N	D4700 ^G	-	-	-	-	N
					√D4547 ^G					
					D6418 ^P					
Modified Syringe Sampler (Hand Use)	-	-	-	N	√D4547 ^G	-	-	-	-	N
Rotating Coring Devices										
Screw Auger	-	-	-	-	-	-	-	-	√	-
Rotating Corer	-	-	-	√D4823 ^G	√D4700 ^G	-	-	-	√	-
Captive Screw Auger	-	-	-	-	-	-	-	N	-	√
Augers										
Hand Operated Bucket Auger	-	-	-	N	√D1452 ^P	-	-	-	-	√D1452 ^P
					D4700 ^G					
					√D6907 ^P					√D6907 ^P
Solid Stem Flighted Auger	-	-	-	-	√D1452 ^G	-	-	-	N	N
					√D6286 ^G					
Hollow Stem Flighted Auger	-	-	-	-	√D5784 ^G	-	-	-	N	N
					√D6151 ^G					
Peat Borer	-	-	-	√	√	-	-	-	-	N
Liquid Profile Devices										
COLIWASA	-	-	-	-	-	√D5495 ^P	√D5495 ^P	-	-	-
						√D5743 ^G	D5743 ^G			
Reuseable Point Sampler	N	-	N	-	-	√D5743 ^G	√D5743 ^G	√	-	-
Drum Thief	-	-	-	-	-	√D5743 ^G	√D5743 ^G	√	-	-
Valved Drum Sampler	-	-	-	-	-	√D5743 ^G	√D5743 ^G	√	-	-
Plunger Type Sampler	N	-	N	-	-	√D5743 ^G	√D5743 ^G	√D5743 ^G	-	-

TABLE 1 *Continued*

Equipment (May be used for discrete sample collection)	Water and Waste Water			Sediment	Soil	Waste				
	Surface Water	Ground Water	Point Discharge			Liquid	Multi-Layer Liquid	Mixed Phase Solid/Liquid	Consolidated Solid	Unconsolidated Solid
Liquids Profiler	N	-	N	-	-	√D6759 ^P	√D6759 ^P	√D6759 ^P	-	-
Surface Sampling Devices (Liquids)										
Bailer	N	√D4448 ^G √D6699 ^P	-	-	-	N	N	-	-	-
Point Sampling Bailer	N	√D4448 ^G √D6699 ^P	-	-	-	N	N	-	-	-
Differential Pressure Bailer	-	√D6699 ^P	-	-	-	N	N	-	-	-
Dipper	√D5358 ^P	-	√D5013 ^P	-	-	√D5358 ^P	-	√D5358 ^P	-	-
Liquid Grab Sampler	√	-	N	-	-	√	√	√	-	-
Swing Jar Sampler	√	-	N	N	-	√	√	N	-	-
Passive Sampler, Bag Type	√	√	-	-	-	-	-	-	-	-
Passive Sampler, Chamber Type	-	√	-	-	-	-	-	-	-	-
Surface Sampling Devices (Solids)										
Impact Devices	-	-	-	-	-	-	-	-	√	-
Spoon	N	-	N	-	√D4700 ^G	N	N	-	-	N
Scoops and Trowel	-	-	-	N	√D4700 ^G	N	-	N	-	√
Shovels	-	-	-	N	√D4700 ^G	-	-	N	-	√
Multi-Level Sampling Devices										
Dedicated Type 1	-	√	-	-	N	-	-	-	-	-
Dedicated Type 2	-	√	-	-	N	-	-	-	-	-
Portable	-	N	-	-	√	-	-	-	-	-
Vadose Zone Pore Sampling Devices										
Vacuum Lysimeter	-	N	-	N	√D4696 ^G	-	-	-	-	-
Vacuum/Pressure Lysimeter	-	N	-	N	√D4696 ^G	-	-	-	-	-
Gas Adsorber	N	N	-	N	√D5314 ^G	-	-	-	-	-

√ = Equipment may be used with this matrix N = Not equipment of choice but use is possible - = Not recommended
^G = ASTM Guide TM = ASTM Test Method ^P = ASTM Practice

<https://standards.iteh.ai>

analyses using polytetrafluoroethylene (PTFE), stainless steel, or glass sampling equipment (1, 2).⁴ Acids, bases, and high chloride ground water in coastal areas, and wastes with high concentrations of solvents may also degrade many types of sampling equipment over time. The residence or contact time, the time the sample is in contact with the sampling equipment may be significant in terms of chemical interaction between the sampled matrix and the equipment.

6.2.1.1 The choice of materials used in the construction of sampling devices should be based upon a knowledge of what constituents may be present in the sampling environment because the constituents and materials may interact chemically or be incompatible. Consult available chemical compatibility charts.

6.2.2 *Physical Compatibility*—The sampling equipment should also be compatible with the physical characteristics of the matrices to be sampled. Equipment used to dig or core (shovels, augers, coring type samplers) should be constructed of material that will not deform during use, or be abraded by the material being sampled. Equipment abrasion may result in the contribution of contaminants to the sample being collected. For example, plastic or glass would not be appropriate for difficult to access matrices, and stainless steel equipment may contribute small amounts of metals if significantly abraded by the matrix.

NOTE 1—Information on sample containers and equipment used in sampling that is not used in the actual collection of the sample is not within the scope of this guide.

6.3 *Equipment Effects on the Matrix:*

6.3.1 *Equipment Design*—Samples collected using inappropriate sampling equipment may not provide *representative samples* (1, 3). An example of equipment design influencing sample results is a sampler which excludes certain sized particles from a soil matrix or waste pile sample. The shape of some scoops may influence the distribution of particle sizes collected from a sample (1). Dredges used to collect river or estuarine stationary sediments may also exclude certain sized particles, particularly the fines fraction which may contain a significant percentage of some contaminants such as polynuclear aromatic hydrocarbons (PAHs).

6.3.2 *Equipment Use*—Inappropriate use of sampling equipment can influence analytical results. For example, if a pump is used to purge a well and the intake is placed below the well screen, sediment in the sump can be put into suspension and become part of the water sample (4). Excessive vacuum generated by sampling pumps can cause loss of volatile constituents or change valence states of some ions. The use of bailers for well purging and sample collection may also cause increased turbidity levels in ground water samples. When sampling containerized liquids, insertion of a COLIWASA sampler at too fast a rate may prevent it from collecting a representative, depth integrated sample.

⁴ The boldface numbers in parentheses refer to the list of references at the end of this standard.

TABLE 2 Sampling Equipment Selection Guide

Equipment	Chemical	Physical	Effect on Sample	Volume Range	Physical	Ease of Operation	Decon	Disposal or Reuse
Pumps and Siphon								
Automatic Sampler–Nonvolatiles	X	X	✓	U	B/P	✓	X	R
Automatic Composite Sampler–Volatiles	X	X	✓	U	B/P	X	X	R
Air/Gas Displacement Pump	✓	X	X	U	P/S/W	X	X	R
Piston Displacement Pump	✓	X	X	U	P/S/W	X	X	R
Bladder Pumps	✓	X	✓	U	P	X	X	R
Corrugated Bladder Pump	✓	X	✓	U	P	✓	X	R
Peristaltic Pump	X	X	✓	U	B/P	X	✓	R
Centrifugal Submersible Pump	X	X	X	U	P/S/W	✓	X	R
Gear Drive Pump	X	X	X	U	B/P	✓	X	D/R
Progressive Cavity Pump	X	X	X	U	P	✓	X	R
Inertia Lift Pump	X	X	X	U	B/N	✓	✓	R
Dredges								
Ekman Dredge	✓	✓	X	0.5-3.0	N	X	X	R
Petersen Dredge	✓	✓	X	0.5-3.0	W	X	X	R
Ponar Dredge	✓	✓	X	0.5-3.0	W	X	X	R
Discrete Depth Samplers								
Bacon Bomb	X	X	✓	0.1-0.94	N	✓	X	R
Kemmerer Sampler	X	X	X	1.0-2.0	N	X	X	R
Syringe Sampler	✓	✓	✓	0.2-0.5	N	✓	X	R
Lidded Sludge/Water Sampler	✓	X	X	1.0	S/W	X	X	R
Discrete Level Sampler	✓	X	✓	0.2-0.5	N	✓	✓	R
Bailer	X	✓	X	0.5-2.0	N	✓	✓	D/R
Point Sampling Bailer	X	✓	✓	0.5-2.0	N	✓	✓	R
Differential Pressure Bailer	✓	✓	✓	0.04-1.0	N	✓	X	R
Dipper	✓	X	✓	0.5-1.0	N	✓	✓	R
Liquid Grab Sampler	✓	✓	✓	0.5-1.0	N	✓	✓	R
Swing Jar Sampler	X	✓	✓	0.5-1.0	N	✓	✓	R
HYDRASleeve	✓	✓	✓	0.6-3.1	N	✓	✓	D
Snap Sampler	✓	✓	✓	0.04-0.35	N	✓	X	R
Drive/Push Samplers								
Direct Push Water Sampler	✓	✓	✓	0.1-0.3	P/S/W	X	X	R
Probe Sampler	✓	✓	X	0.2-2.0	S/W	X	✓	R
Split Barrel Sampler	✓	✓	X	0.5-30.0	S/W	X	✓	R
Thin Walled Tube	✓	✓	X	0.5-5.0	S/W	✓	✓	R
Coring Type w/Valve	✓	✓	✓	0.2-1.5	N	✓	✓	R
Concentric Tube Thief	✓	✓	✓	0.5-1.0	N	✓	✓	R
Trier	✓	✓	✓	0.1-0.5	N	✓	✓	R
Miniature Core Sampler	✓	✓	✓	0.01-0.05	N	✓	✓	D
Modified Syringe Sampler	✓	✓	✓	0.01-0.05	N	✓	X	D
Rotating Coring Devices								
Screw Auger	✓	X	X	0.1-0.3	N	X	✓	R
Rotating Corer	✓	✓	X	0.5-1.0	B/P	✓	✓	R
Captive Screw Auger	X	✓	X	1-2	P	✓	✓	R
Augers								
Bucket Auger	✓	X	X	0.2-1.0	N	X	✓	R
Solid Stem Flighted Auger	X	✓	X	U	P/S/W	X	✓	R
Hollow Stem Flighted Auger	X	✓	X	U	P/S/W	X	✓	R
Peat Borer	X	✓	✓	0.3	S	X	X	R
Liquid Profile Devices								
COLIWASA	✓	X	✓	0.5-3.0	N	✓	X	D/R
Reuseable Point Sampler	✓	✓	✓	0.2-0.6	N	✓	✓	R
Drum Thief	✓	X	✓	0.1-0.5	N	✓	X	D/R
Valved Sampler	✓	✓	✓	0.3-1.6	N	✓	✓	D/R
Plunger Type Sampler	✓	X	✓	0.2-U	N	✓	✓	D/R
Liquids Profiler	X	X	✓	1.3-4.0	N	✓	✓	R
Passive Water Sampling Devices								
Passive Sampler, Bag Type	✓	✓	✓	0.1-0.2	N	✓	✓	D/R
Passive Sampler, Chamber Type	✓	✓	✓	1-4	W/S	X	X	D/R
Multi-Level Sampling Devices								
Dedicated Type 1	✓	✓	✓	U	W/S	X	X	D/R
Dedicated Type 2	✓	✓	✓	U	W/S	X	X	D
Portable	✓	✓	✓	0.01	N	X	X	DR
Surface Sampling Devices (Solids)								
Impact Devices	X	X	X	N/A	B/P	✓	✓	R
Spoon	✓	✓	X	N/A	N	✓	✓	R
Scoops and Trowel	✓	✓	X	0.1-0.6	N	✓	✓	R
Shovels	✓	✓	X	1.0-5.0	N	✓	✓	R
Vadose Zone Pore Sampling Devices								
Vacuum Lysimeter	✓	✓	✓	0.1-0.5	N	✓	✓	D/R
Vacuum/Pressure Lysimeter	✓	✓	✓	0.1-0.5	S/P	✓	✓	D
Gas Adsorber	✓	✓	✓	N/A	N	✓	✓	D

Equipment	Chemical	Physical	Effect on Sample	Volume Range	Physical	Ease of Operation	Decon	Disposal or Reuse
X = Significant operational consideration √ = Not a significant operational consideration		Range of Volume (liters) U = Unlimited N/A = Not Applicable			Physical Requirements: B = Battery W = Weight P = Power S = Size N = No limitations			Disposal and Reuse: R = Reusable D = Single-Use

6.4 *Sample Volume Capabilities*—Most sampling devices will provide adequate sample volume. ~~How ever, However,~~ the sampling equipment volumes should be compared to the volume necessary for all required analyses including the additional amount necessary for quality control (QC), split and repeat samples (4, 5). Sampling devices which may not provide an adequate volume would be small diameter glass tubes, and triers. In this case, the investigator must consider the following options:

- 6.4.1 A similar device with an increased capacity,
- 6.4.2 An alternate device with an increased capacity, or
- 6.4.3 Modification of an existing device (often difficult or impractical).

6.4.4 If these alternatives are not acceptable or available, then the investigator must consider the collection of multiple aliquots to fulfill the sample volume requirement. The effect of multiple aliquots on the data quality objectives should be considered.

6.5 *Physical Requirements*—Sampling equipment selection should always consider factors such as the size and weight of the equipment, power requirements (battery/110V), and ancillary equipment required (drill rig for split barrel samplers). Most sampling equipment used in the collection of environmental samples is relatively easy to transport and use in the field. The use of equipment with significant physical requirements may impede the progress of a sampling investigation.

6.6 *Ease of Operation*—Much of the equipment used for environmental sampling is rather simple to employ. Samples may be collected easily as long as properly selected equipment is used with adequate consideration of the matrix of interest. Sampling errors may occur as a result of inadequate consideration of matrix effects, and poor collection techniques (1, 3). Training requirements should focus on the proper use of equipment in varying environmental matrices.

6.7 *Decontamination and Reuse of Equipment:*

6.7.1 *Decontamination (see Practice D5088)*—Inadequate decontamination of sampling equipment can result in significant errors in analytical results. When choosing sampling equipment, ease of decontamination must be a consideration. Pumps, automatic samplers, Kemmerer samplers and dredges require more effort to decontaminate than does a bailer or split barrel sampler. The investigator should consider decontamination requirements prior to the study to avoid significant delays.

6.7.2 *Reuse*—Due to the expense of materials associated with modern sampling equipment (stainless steel, PTFE), most equipment is reusable following proper decontamination. Some equipment such as bailers may be disposed of after use or dedicated to a sampling point to save time during extensive field investigations. Drum thieves and COLIWASA samplers are typically not reused, particularly when waste samples have been collected.

6.8 *Cost*—Detailed information on the cost of sampling equipment is not contained within this guide. Cost is usually a major consideration in the process of sampling equipment selection. In general, the cost of PTFE and stainless steel equipment will be greater than equipment made of glass, PVC, or other plastics. However, the life expectancy for PTFE or stainless steel equipment is usually longer. In addition, labor costs for decontamination of reusable equipment versus the disposal costs of single use equipment are also relevant considerations. Comments on costs are included in the “Advantages and Limitations” tables, where appropriate.

7. Sampling Equipment

7.1 Presented below are brief descriptions of some sampling equipment used in waste management and in the collection of environmental samples as they relate to waste management activities (6). This is by no means an inclusive list of the sampling equipment which is available to investigators. There are many pieces of equipment that have been designed for specific sampling needs. In addition, investigators may design their own pieces of equipment for a specific project. In all these instances, an investigator must keep in mind the criteria for sampling equipment selection which have been discussed previously in this guide.

7.2 *Pumps and Siphons (see Guide D4448)*—Pumps used for the collection of waste and environmental liquid samples for waste management include automatic samplers and displacement, bladder, peristaltic and centrifugal pumps.

7.2.1 *Automatic Samplers (see Guide D6538)*—Automatic samplers may be used when samples are to be collected at frequent intervals (see Figs. 1 and 2). They are frequently used in waste water collection systems and treatment plants, but they can also be used during stream sampling investigations. They may be used to collect time composite or flow proportional samples. In the flow proportional sampling mode, the samplers are activated by a compatible flow meter. Peristaltic and vacuum pumps are commonly employed as the sampling mechanism. Automatic samplers designed specifically for the collection of samples for volatile organic analyses are available. See Table 4 for advantages and limitations.

NOTE 2—Flow proportional samples can also be collected using a discrete sampler and a flow recorder and manually compositing the individual aliquots in flow proportional amounts.

TABLE 3 Index of Sampling Equipment

Media Type	Sampler Type	Section	Sample Type
Consolidated Solid	Rotating Corer	(7.6.2)	Surface or Depth, Undisturbed
	Screw Auger	(7.6.1)	Surface, Disturbed
	Impact Device	(7.11.1)	Surface, Disturbed
Unconsolidated Solid	Lidded Sludge	(7.4.4)	Discrete, Composite
	Probe Sampler	(7.5.2)	Discrete, Undisturbed
	Split Barrel	(7.5.3)	Discrete, Undisturbed
	Concentric Tube Thief	(7.5.7.1)	Surface, Disturbed, Selective
	Trier	(7.5.7.2)	Surface, Relatively Undisturbed, Selective
	Thin Walled Tube	(7.5.5)	Surface or Depth, Undisturbed
	Coring Type w/Valve	(7.5.6)	Surface or Depth, Disturbed
	Hand-Operated Bucket Auger	(7.7.1)	Surface or Depth, Disturbed
	Solid Stem Flighted Auger	(7.7.2.1)	Surface or Depth, Disturbed
	Hollow Stem Flighted Auger	(7.7.2.2)	Surface or Depth, Disturbed (if from flights)
	Captive Screw Auger	(7.6.3)	Discrete, Disturbed
	Peat Borer	(7.7.3)	Discrete, Relatively Undisturbed
	Spoon	(7.11.2)	Surface, Disturbed, Selective
	Scoops/Trowel	(7.11.3)	Surface, Disturbed, Selective
	Shovel	(7.11.4)	Surface, Disturbed
	Miniature Core	(7.5.8)	Surface, Undisturbed
Modified Syringe	(7.5.9)	Surface, Undisturbed	
Soil	Probe Sampler	(7.5.2)	Discrete, Undisturbed
	Split Barrel	(7.5.3)	Discrete, Undisturbed
	Trier	(7.5.7.2)	Surface, Relatively Undisturbed, Selective
	Thin Walled Tube	(7.5.5)	Surface or Depth, Undisturbed
	Coring Type w/Valve	(7.5.6)	Surface or Depth, Disturbed
	Hand-Operated Bucket Auger	(7.7.1)	Surface or Depth, Disturbed
	Solid Stem Flighted Auger	(7.7.2.1)	Surface or Depth, Disturbed
	Hollow Stem Flighted Auger	(7.7.2.2)	Surface or Depth, Disturbed (if from flights)
	Peat Borer	(7.7.3)	Discrete, Relatively Undisturbed
	Spoon	(7.11.2)	Surface, Disturbed, Selective
	Scoops/Trowel	(7.11.3)	Surface, Disturbed, Selective
	Shovel	(7.11.4)	Surface, Disturbed
	Miniature Core	(7.5.8)	Surface, Undisturbed
	Modified Syringe	(7.5.9)	Surface, Undisturbed
	Vacuum Lysimeter	(7.12.1)	Surface to Depth, Pore Liquid
	Vacuum/Pressure Lysimeter	(7.12.2)	Depth, Pore Liquid
Gas Adsorber	(7.12.3)	Surface to Depth, Soil Gas	
Mixed Solid/Liquid	AutoSampler, Non V.	(7.2.1)	Shallow, Composite-Suspended Solids only
	Peristaltic Pump	(7.2.5)	Shallow, Discrete or Composite-Suspended Solids Only
	Syringe Sampler	(7.4.3)	Shallow, Discrete, Disturbed
	Lidded Sludge/Water	(7.4.4)	Discrete, Composite
	Probe Sampler	(7.5.2)	Depth, Discrete, Undisturbed
	Split Barrel	(7.5.3)	Depth, Discrete, Undisturbed
	Peat Borer	(7.7.3)	Discrete, Relatively Undisturbed
	Trier	(7.5.7.2)	Surface, Semi-solid only, Selective
	Coring Type w/Valve	(7.5.6)	Depth, Disturbed
	COLIWASA	(7.8.1)	Shallow, Composite, Semi-liquid only
	Reuseable Point	(7.8.1.2)	Shallow, Discrete
	Plunger Type	(7.8.4)	Shallow, Discrete
	Liquids Profiler	(7.8.5)	Depth, Composite-Suspended Solids only
	Drum Thief	(7.8.2)	Shallow, Composite-Semi-Liquid only
	Valved	(7.8.3)	Shallow, Composite-Semi-Liquid only
	Dipper	(7.4.9)	Shallow, Composite
Liquid Grab	(7.4.10)	Shallow, Composite-Suspended Solids only	
Swing Jar	(7.4.11)	Shallow, Composite	
Scoops/Trowel	(7.11.3)	Shallow, Composite, Semi-solid only	
Shovel	(7.11.4)	Shallow, Composite, Semi-solid only	
Sediments	Ekman Dredge	(7.3.1)	Bottom Surface, Soft only, Disturbed
	Petersen Dredge	(7.3.2)	Bottom Surface, Rocky or Soft, Disturbed
	Ponar	(7.3.3)	Bottom Surface, Rocky or Soft, Disturbed
	Probe Sampler	(7.5.2)	Bottom Surface or Depth, Undisturbed
	Split Barrel	(7.5.3)	Bottom Surface or Depth, Relatively Undisturbed
	Thin Walled Tube	(7.5.5)	Bottom Surface or Depth, Undisturbed
	Coring Type w/Valve	(7.5.6)	Bottom Surface or Depth, Disturbed
	Hand-Operated Bucket Auger	(7.7.1)	Bottom Surface, Disturbed
	Peat Borer	(7.7.3)	Discrete, Relatively Undisturbed
	Rotating Corer	(7.6.2)	Bottom Surface, Undisturbed if solid
	Scoops, Trowel	(7.11.3)	Exposed Surface only, Disturbed, Selective
	Shovel	(7.11.4)	Exposed Surface only, Disturbed
	Miniature Core	(7.5.8)	Exposed Surface only, Undisturbed
	Modified Syringe	(7.5.9)	Exposed Surface only, Undisturbed
	Auto Splr. - Non Vols.	(7.2.1)	25-ft Lift, Discrete or Composite
	Auto Splr. - Vols.	(7.2.1)	25-ft Lift, Discrete
Peristaltic Pump	(7.2.5)	Shallow(25-ft), Discrete	
Centrifugal Sub. Pump	(7.2.6)	Depth, Discrete	

TABLE 3 *Continued*

Media Type	Sampler Type	Section	Sample Type
Surface Water	Gear Drive Pump	(7.2.7)	Depth, Discrete
	Progressing Cavity Pump	(7.2.8)	Depth, Discrete
	Bacon Bomb	(7.4.1)	Depth, Discrete
	Kemmerer	(7.4.2)	Depth, Discrete
	Discrete Level	(7.4.5)	Depth, Discrete
	Plunger Type	(7.8.4)	Shallow (12-ft), Discrete
	Liquids Profiler	(7.8.5)	Shallow, Composite
	Dipper	(7.4.9)	Shallow (10-ft.), Composite
	Liquid Grab	(7.4.10)	Shallow (6-ft), Composite
	Swing Jar	(7.4.11)	Shallow, (10-ft), Composite
	Spoon	(7.11.2)	Shallow (1-in.), Composite
Ground Water	Air/Gas Displacement	(7.2.2.1)	Depth, Discrete
	Piston Displacement	(7.2.2.2)	Depth, Discrete
	Bladder Pump	(7.2.3)	Depth, Discrete
	Corrugated Bladder Pump	(7.2.4)	Depth, Discrete
	Peristaltic Pump	(7.2.5)	25-ft Lift, Discrete
	Centrifugal Sub. Pump	(7.2.6)	Depth, Discrete
	Gear Drive Pump	(7.2.7)	Depth, Discrete
	Progressing Cavity Pump	(7.2.8)	Depth, Discrete
	Inertia Lift Pump	(7.2.9)	Depth Discrete
	Discrete Level	(7.4.5)	Depth, Discrete
	Direct Push Water Sampler	(7.5.1.1)	Depth, Discrete
	Bailer	(7.4.6)	Depth, Composite
	Point Sampling Bailer	(7.4.7)	Depth, Discrete
	Diff. Pressure Bailer	(7.4.8)	Depth, Discrete
	Bag Type Diffusion	(7.9.1)	Depth Discrete
	Chamber Type Diffusion	(7.9.2)	Multiple Depths, Discrete
Dedicated Multi-Level	(7.10.1)	Multiple Depths, Discrete	
	Portable Multi-Level	(7.10.2)	Multiple Depths, Discrete, Pore water
Liquid Effluent	AutoSpr. -Non Vols.	(7.2.1)	Shallow (25-ft), Discrete or Composite
	Auto Spr. - Vols.	(7.2.1)	Shallow (25-ft), Discrete
	Peristaltic Pump	(7.2.5)	Shallow (25-ft), Discrete
	Centrifugal Sub. Pump	(7.2.6)	Depth, Discrete
	Gear Drive Pump	(7.2.7)	Depth, Discrete
	Progressing Cavity Pump	(7.2.8)	Depth, Discrete
	Bacon Bomb	(7.4.1)	Depth, Discrete
	Kemmerer	(7.4.2)	Depth, Discrete
	<u>HYDRASleeve</u>	<u>(7.4.12)</u>	<u>Depth, Discrete</u>
	<u>Snap Sampler</u>	<u>(7.4.13)</u>	<u>Depth, Discrete</u>
	Syringe Sampler	(7.4.3)	Shallow (8-ft), Discrete
	Discrete Level	(7.4.5)	Depth, Discrete
	Reuseable Point	(7.8.1.2)	Shallow (8-ft), Discrete
	Valved Sampler	(7.8.3)	Shallow, Discrete
	Plunger Type	(7.8.4)	Shallow (12-ft), Discrete
	Liquids Profiler	(7.8.5)	Shallow, Composite
Dipper	(7.4.9)	Shallow (10-ft), Composite	
Liquid Grab	(7.4.10)	Shallow (6-ft), Composite	
Swing Jar	(7.4.11)	Shallow (10-ft), Composite	
	Spoon	(7.11.2)	Shallow (1-in.), Composite
Liquid	Air Displacement Pump	(7.2.2.1)	Depth, Discrete
	Piston Displacement	(7.2.2.2)	Depth, Discrete
	Bladder Pump	(7.2.3)	Depth, Discrete
	Corrugated Bladder Pump	(7.2.4)	Depth, Discrete
	Peristaltic Pump	(7.2.5)	Shallow (25-ft), Discrete
	Centrifugal Sub. Pump	(7.2.6)	Depth, Discrete
	Gear Drive Pump	(7.2.7)	Depth, Discrete
	Progressing Cavity Pump	(7.2.8)	Depth, Discrete
	Syringe Sampler	(7.4.3)	Shallow (8-ft), Discrete
	Lidded Sludge/Water	(7.4.4)	Shallow (8-ft), Discrete
	Discrete Level	(7.4.5)	Depth, Discrete
	Direct Push Water Sampler	(7.5.1.1)	Depth, Discrete
	COLIWASA	(7.8.1)	Shallow (4-ft), Composite
	Reuseable Point	(7.8.1.2)	Shallow (8-ft), Discrete
	Plunger Type	(7.8.4)	Shallow, (12-ft), Discrete
	Liquids Profiler	(7.8.5)	Shallow, Composite
	Drum Thief	(7.8.2)	Shallow (3-ft), Composite
	Valved Sampler	(7.8.3)	Shallow (8-ft), Composite
	Bailer	(7.4.6)	Depth, Discrete
	Point Sampling Bailer	(7.4.7)	Depth, Discrete
	Diff. Pressure Bailer	(7.4.8)	Depth, Discrete
	Dipper	(7.4.9)	Shallow (10-ft), Composite
Liquid Grab	(7.4.10)	Shallow (6-ft), Composite	
Swing Jar	(7.4.11)	Shallow, (10-ft), Composite	
	Spoon	(7.11.2)	Shallow (1-in.), Composite
	Scoops & Trowel	(7.11.3)	Shallow, (1-in.), Composite

TABLE 3 Continued

Media Type	Sampler Type	Section	Sample Type
Multi Layer Liquid	Air Displacement Pump	(7.2.2.1)	Depth, Discrete
	Piston Displacement	(7.2.2.2)	Depth, Discrete
	Bladder Pump	(7.2.3)	Depth, Discrete
	Corrugated Bladder Pump	(7.2.4)	Depth, Discrete
	Peristaltic Pump	(7.2.5)	Shallow(25-ft), Discrete
	Centrifugal Sub. Pump	(7.2.6)	Depth, Discrete
	Gear Drive Pump	(7.2.7)	Depth, Discrete
	Progressing Cavity Pump	(7.2.8)	Depth, Discrete
	Syringe Sampler	(7.4.3)	Shallow (8-ft), Discrete
	Discrete Level	(7.4.5)	Depth, Discrete
	Direct Push Water Sampler	(7.5.1.1)	Depth, Discrete
	COLIWASA	(7.8.1)	Shallow (4-ft), Composite
	Reuseable Point	(7.8.1.2)	Shallow (8-ft), Discrete
	Plunger Type	(7.8.4)	Shallow, (12-ft), Discrete
	Liquids Profiler	(7.8.5)	Shallow, Composite
	Drum Thief	(7.8.2)	Shallow (3-ft), Composite
	Valved Sampler	(7.8.3)	Shallow (8-ft), Composite
	Bailer	(7.4.6)	Depth, Discrete
	Point Sampling Bailer	(7.4.7)	Depth, Discrete
	Diff. Pressure Bailer	(7.4.8)	Depth, Discrete
	Dipper	(7.4.9)	Shallow (10-ft), Composite
Liquid Grab	(7.4.10)	Shallow (6-ft), Composite	
Swing Jar	(7.4.11)	Shallow (10-ft), Composite	

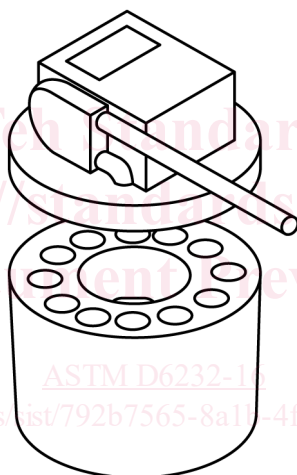

FIG. 1 Automatic Sampler—Non Volatiles

7.2.2 Displacement Pumps (see Guide D4448, Practice D6771)—Displacement pumps are designed for ground water sampling and mechanically force a discrete column of water to the surface. The air displacement pump uses compressed air. The piston displacement pump uses an actuating rod powered either from the surface or from a separate sealed air or electric actuator. (See Table 5 for advantages and limitations.)

7.2.2.1 The air displacement pump (Fig. 3) operates by applying a positive pressure to the gas line causing the inlet check valve of the sampling device to close and the sample discharge line check valve to open, forcing the contents to the surface. Cyclical removal of gas pressure will cause the flow to stop, the discharge line check valve to close and the inlet check valve of the sampling device to open, allowing the sampling device to fill.

7.2.2.2 The piston displacement pump (Fig. 4) uses a mechanically operated plunger to deliver the sample to the surface at the same time as the chamber fills. It has a flexible flap valve on the piston and an inlet check valve.

7.2.3 Bladder Pumps—Bladder pumps are used for sampling ground water, and are constructed with a flexible bladder inside a rigid sample container. There are two types. The squeeze type (Fig. 5) has the bladder connected to the sample discharge line. The chamber between the bladder and the sampler body is connected to the gas line. The expanding type (Fig. 6) has the bladder connected to the gas line with the sample discharge line connected to the chamber surrounding the bladder.

7.2.3.1 The pump operates by applying a positive pressure to the gas line causing either the bladder to expand or be compressed, dependent dependent on the type. The sampler inlet valve closes and the sample discharge valve opens forcing the contents of the sampler up the discharge line. Cyclic removal of the gas pressure causes the flow to stop, the sample valve to close and the sampler inlet valve to open, allowing the sampler to refill. See Table 6 for advantages and limitations.

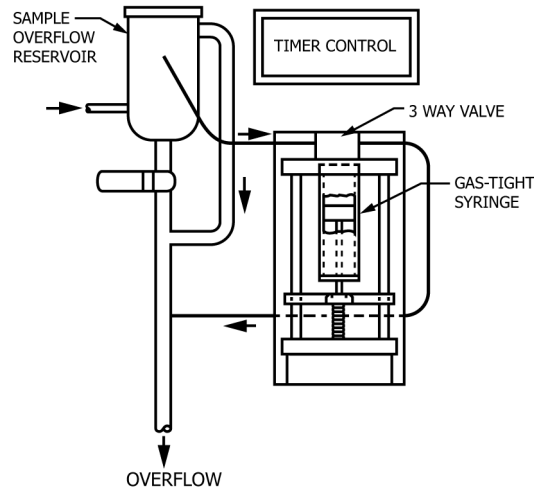

FIG. 2 Automatic Composite Sampler—Volatiles

TABLE 4 Automatic Samplers—Advantages and Limitations

Advantages	Limitations
Can collect either grab samples over time or a composite sample	May be unsuitable for samples requiring volatile organic analysis or samples containing dissolved gases
Will operate unattended	Need power source/battery
Versatile—can be programmed to sample proportional to flow	May be difficult to decontaminate due to design or construction materials, or both
	May be incompatible with liquid streams containing a high percentage of solids

TABLE 5 Displacement Pumps—Advantages and Limitations

Advantages	Limitations
Commonly constructed on PVC, or stainless steel, or both, but can be constructed of fluoropolymer to reduce risk of contamination when trace levels of organics are of interest	Potential loss of dissolved gases and VOCs from the pumped sample or contamination from the driving gas
Commonly constructed of PVC, or stainless steel, or both, but can be constructed of fluoropolymer to reduce risk of contamination when trace levels of organics are of interest	Potential loss of dissolved gases and VOCs from the pumped sample or contamination from the driving gas
Easy to decontaminate (air displacement)	Compressed gas or mechanical actuation required for operation
Flow rate is adjustable	May be difficult to decontaminate (piston displacement)

7.2.4 *Corrugated Bladder Pump*—This variation on the bladder pumps covered in 7.2.3 uses a corrugated fluoropolymer bladder that is alternately compressed and expanded in a vertical axis by mechanical means to pump the sample to the surface (Fig. 7). The inner concentric tube is attached to the corrugated bladder and is used to mechanically open and close the bladder pumping water to the surface through the inner tube. This pump is available in only a 12 mm (0.47 in.) diameter and is used for sampling through small diameter direct push tools and wells. See Table 7 for advantages and limitations.

7.2.5 *Peristaltic Pump (4)*—A peristaltic pump is a suction lift pump which is used at the ground surface (see Fig. 8(a)). A length of fluoropolymer or other suitable tubing is placed in the liquid and the other end is connected to the piece of flexible tubing which has been threaded around the rotor of the peristaltic pump. A second piece of fluoropolymer or other suitable tubing is connected

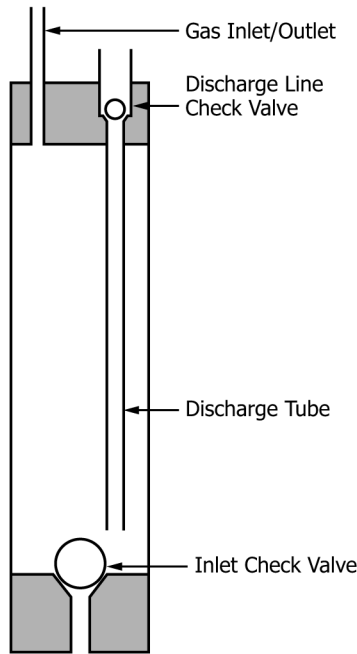

FIG. 3 Air/Gas Displacement Pump

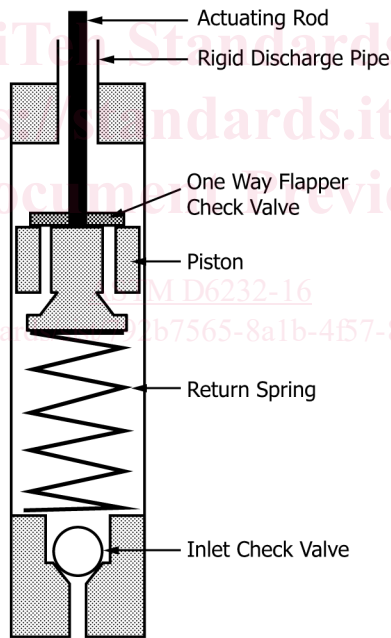

FIG. 4 Piston Displacement Pump

to the discharge end of the flexible tubing to allow the water to be containerized, (see Fig. 8 (b)) sampled etc. If the pump tubing is not compatible with the sample parameters of concern, a modification to the system is necessary.

7.2.5.1 The modification (see Fig. 8(c)) consists of a peristaltic pump using fluoropolymer tubing and a fluoropolymer insert to collect samples without the sample coming into contact with the pump tubing. This is accomplished by placing the fluoropolymer insert into the opening of a clean glass container. The fluoropolymer tubing connects the container to the pump and the sample source.

7.2.5.2 The operation of the peristaltic pump results from the rotor compressing the flexible tubing causing a vacuum to be applied to the inlet tubing. The water is drawn up the inlet tubing and into the container, without coming into contact with the pump flexible tubing.

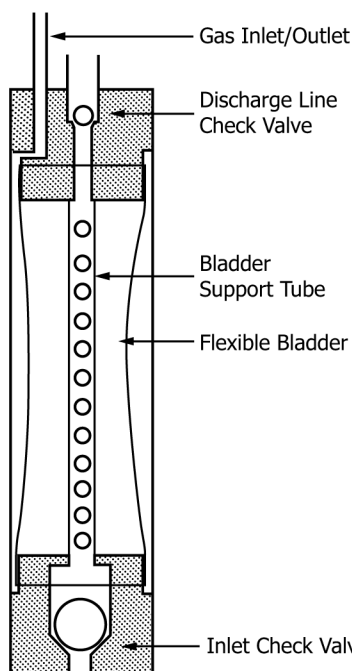

FIG. 5 Bladder Pump—Squeeze Type

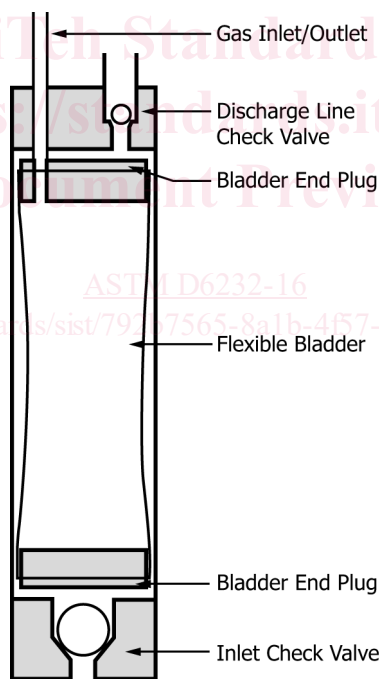

FIG. 6 Bladder Pump—Expanding Type

7.2.5.3 Samples for purgeable organic compounds analyses may be collected by attaching the fluoropolymer tubing to the intake side of the peristaltic pump, pumping the tubing full of the liquid, disconnecting the tubing, and allowing the fluoropolymer tube to drain into the sample vials. A peristaltic pump can also be used to mix and sample liquids from drums (see Guide D6063). See Table 8 for advantages and limitations.

7.2.6 *Centrifugal Submersible Pump* (see Guide D4448, Practice D6771)—Centrifugal submersible pumps (Fig. 9) may be used for purging and sampling monitoring wells, waste water impoundments or point discharges. Water contacting parts may be made of fluoropolymer and stainless steel. The motor cavity may be either filled with air, deionized, or distilled water that may be replaced as necessary. The pump may be controlled by either a 12V (DC) or a 110/220V (AC) converter. Flow rates range from 9 gallons per minute down to 100 milliliters per minute. The pump discharge hose may be made of fluoropolymer or other suitable material.