



Designation: ~~D3806 – 98 (Reapproved 2011)~~ **D3806 – 98 (Reapproved 2016)**

Standard Test Method of Small-Scale Evaluation of Fire-Retardant Paints (2-Foot Tunnel Method)¹

This standard is issued under the fixed designation D3806; the number immediately following the designation indicates the year of original adoption or, in the case of revision, the year of last revision. A number in parentheses indicates the year of last reapproval. A superscript epsilon (ϵ) indicates an editorial change since the last revision or reapproval.

1. Scope

1.1 This test method determines the protection a coating affords its substrate, and the comparative burning characteristics of coatings by evaluating the flame spread over the surface when ignited under controlled conditions in a small tunnel. This establishes a basis for comparing surface-burning characteristics of different coatings without specific consideration of all the end-use parameters that might affect surface-burning characteristics under actual fire conditions.

1.2 In addition to the experimental ~~flame spread~~ flame spread rate, the weight of panel consumed, time of afterflaming and afterglow, char dimensions and index, and height of intumescence may be measured in this test. However, a relationship should not be presumed among these measurements.

1.3 This standard should be used to measure and describe the properties of materials, products, or assemblies in response to heat and flame under controlled laboratory conditions, and should not be used to describe or appraise the fire hazard or fire risk of materials, products, or assemblies under actual fire conditions. However, results of this test may be used as elements of a fire risk assessment which takes into account all of the factors which are pertinent to an assessment of the fire hazard of a particular end use.

1.4 The values stated in SI units are to be regarded as the standard. The values given in parentheses are for information only.

1.5 *This standard does not purport to address all of the safety concerns, if any, associated with its use. It is the responsibility of the user of this standard to establish appropriate safety and health practices and determine the applicability of regulatory limitations prior to use.*

2. Referenced Documents

2.1 *ASTM Standards:*²

[C220 Specification for Flat Asbestos-Cement Sheets](#)

[D344 Test Method for Relative Hiding Power of Paints by the Visual Evaluation of Brushouts](#)

[D1475 Test Method For Density of Liquid Coatings, Inks, and Related Products](#)

[D2196 Test Methods for Rheological Properties of Non-Newtonian Materials by Rotational Viscometer](#)

[E84 Test Method for Surface Burning Characteristics of Building Materials](#)

2.2 *Federal Standard:*

[Fed. Spec. TT-V-119 Varnish, Spar, Phenolic Resin](#)³

3. Significance and Use

3.1 A number of laboratory procedures are used to evaluate the effectiveness of fire-retardant and fire-resistant treatments and coatings. In general, these methods measure the three stages of fire development: (1) ignition; (2) flame spread (rate of growth of the fire); and (3) conflagration extent. While all three are of extreme importance, flame spread has been recognized as the main factor associated with testing fire-retardant coatings.

¹ This test method is under the jurisdiction of ASTM Committee D01 on Paint and Related Coatings, Materials, and Applications and is the direct responsibility of Subcommittee D01.21 on Chemical Analysis of Paints and Paint Materials.

Current edition approved June 1, 2011/Dec. 1, 2016. Published June 2011/December 2016. Originally approved in 1979. Last previous edition approved in 2004/2011 as D3806 – 98 (2004) (2011). DOI: [10.1520/D3806-98R11](https://doi.org/10.1520/D3806-98R11); [10.1520/D3806-98R16](https://doi.org/10.1520/D3806-98R16).

² For referenced ASTM standards, visit the ASTM website, www.astm.org, or contact ASTM Customer Service at service@astm.org. For *Annual Book of ASTM Standards* volume information, refer to the [standard's Document Summary page](#) on the ASTM website.

³ Available from [Standardization Documents Order Desk, DODSSP, Bldg. 4, Section D, DLA Document Services, Building 4/D, 700 Robbins Ave., Philadelphia, PA 19111-5098](#), <http://dodssp.daps.dla.mil>; <http://19111-5094>, <http://quicksearch.dla.mil>.

3.2 Flame spread ratings based upon Test Method E84 have acquired common acceptance by regulatory agencies, but such large-scale tests are seldom practical during the development or modification of a fire-retardant coating.

3.3 This test method provides the relative flame spread of experimental coatings using small test specimens. By calibrating the 2-foot tunnel with Test Method E84-rated fire-retardant paint, results obtained by this test method should be indicative of those obtained with a large specimen in the Test Method E84 tunnel.

4. Apparatus

4.1 *Flame Tunnel*⁴ (see Fig. 1A)—610-mm (two-foot) flame tunnel consisting of asbestos-cement board mounted on an iron framework and supplied with natural gas fuel of uniform quality.

4.1.1 The framework is constructed of 3 by 25 by 25-mm ($\frac{1}{8}$ by 1 by 1-in.) angle iron, the top of which provides a 610 by 100-mm (24 by 4-in.) specimen holder inclined at 28° to the horizontal. The framework is mounted on a 250 by 610 by 13-mm (10 by 24 by $\frac{1}{2}$ -in.) steel base. The specimen holder is elevated 185 mm ($7\frac{3}{8}$ in.) above the base at the lower (fire) end and 480 mm ($18\frac{7}{8}$ in.) at the upper (flue) end.

4.1.2 The fire end and sides of the tunnel are covered to the extent shown in Fig. 1, with 6-mm ($\frac{1}{4}$ -in.) asbestos-cement board⁵ or 6-mm ($\frac{1}{4}$ -in.) inorganic reinforced-cement board⁶ attached to the inside of the angle iron framework. The open flue end and the cut-out sides allow a natural draft through the tunnel. Additional air access is provided by a 25-mm (1-in.) hole drilled in the cover at the fire end, centered and 115 mm ($4\frac{1}{2}$ in.) above the base.

4.1.3 An observation window made of a 50-mm (2-in.) wide strip of 3-mm ($\frac{1}{8}$ -in.) polished heat-resistant sheet glass⁷ is located just below the specimen holder, extending the full length of the tunnel, 610 mm (24 in.). This glass is marked by any appropriate method at 1-in. intervals from 4 to 22 in. A 560 by 55 by 2-mm (22 by $2\frac{1}{4}$ by $\frac{1}{16}$ -in.) sheet metal shield is attached above the window, slanting downwards at an angle of 60° to shield the observation window. The angle iron panel holder is notched along the bottom or supporting lip of the angle at 25-mm (1-in.) intervals to assist in the measurements of the flame advance.

NOTE 1—A rule may also be mounted outside the observation window to help measure the flame advancement.

4.1.4 A 2.5-mm ($\frac{3}{32}$ -in.) hole is drilled in the side of the specimen holder immediately above the center of the burner to allow insertion of a thermocouple.

4.1.5 The tunnel should be placed in an area as free from drafts as possible with facilities for removal or escape of combustion products. (Standard laboratory hood with forced draft off during test.)

4.2 *Burner*,⁸ 215 mm (8.5 in.) high with 40-mm diameter, 10-mm thick grid for use with natural gas. The burner is placed 57 mm ($2\frac{1}{4}$ in.) in from the fire end of the tunnel and 25 mm (1 in.) below the bottom side of the sample holder, that is, 30 mm ($1\frac{1}{8}$ in.) from the bottom of the specimen. See Fig. 1.

NOTE 2—Artificial gas or liquid petroleum (LP) gas may be used, but burners designed for these types of gases must be used.

4.3 *Ignition Transformer*, or other suitable ignition source, to generate a spark through a 2-mm ($\frac{1}{16}$ -in.) Nichrome wire to the burner barrel. The transformer is activated by a push-button type spark switch.

4.4 *Gas Supply*, of uniform quality controlled by a positive-flow pressure regulatory valve (0 to 152 mm (0 to 6 in.) water) and a gas flowmeter (0.6 to 5.0 SCFH).

4.5 *Insulating and Fire Resistant Backing for Test Panels*, consisting of 100 by 605-mm ($3\frac{7}{8}$ by $23\frac{7}{8}$ -in.) pieces of 13-mm ($\frac{1}{2}$ -in.) asbestos-cement board or inorganic reinforced cement board and $\frac{1}{2}$ -in. steel plate applied one above the other with asbestos cement or the inorganic reinforced cement board placed directly on top of the test panel.

4.6 *Thermocouple*⁹ totally shielded (see Note 3), installed through the hole in the side of the specimen holder so that its tip rests on the back, cool side, of the test panel.

NOTE 3—Some commercial tunnels are supplied with more than one thermocouple.

⁴ The sole source of supply of a suitable cabinet and assembly known to the committee at this time is Dek-Tron Scientific, 244 East 3rd St., Plainfield, NJ 07060. If you are aware of alternative suppliers, please provide this information to ASTM International Headquarters. Your comments will receive careful consideration at a meeting of the responsible technical committee,¹ which you may attend.

⁵ The sole source of supply of an asbestos-cement board, transite, known to the committee at this time is Manville Corp., Denver CO 80217. If you are aware of alternative suppliers, please provide this information to ASTM International Headquarters. Your comments will receive careful consideration at a meeting of the responsible technical committee,¹ which you may attend.

⁶ The sole source of supply of inorganic reinforced-cement board, #100S and 100H, nominal 1600 to 1760 kg/m³ (100 to 110 lb/ft³), known to the committee at this time is Shameful Corp., 100 Spence Lane, Nashville, TN 37210. If you are aware of alternative suppliers, please provide this information to ASTM International Headquarters. Your comments will receive careful consideration at a meeting of the responsible technical committee,¹ which you may attend.

⁷ Quartz or high-silica glass has been found satisfactory for this purpose.

⁸ The sole source of supply of a burner, Catalog No. 3-902 for artificial gas, or Catalog No. 3-900 and 3-902 for natural gas and LP gas, respectively, known to the committee at this time is Fisher Scientific Co. If you are aware of alternative suppliers, please provide this information to ASTM International Headquarters. Your comments will receive careful consideration at a meeting of the responsible technical committee,¹ which you may attend.

⁹ The sole source of supply of a thermocouple, Megopak Type J, known to the committee at this time is Megopak Co. If you are aware of alternative suppliers, please provide this information to ASTM International Headquarters. Your comments will receive careful consideration at a meeting of the responsible technical committee,¹ which you may attend.

Materials of Construction and Equipment List

Item No	Item	Description	Item No	Item	Description
A	Base Plate	1/2 x 10 x 24 Steel plate	F	Glare Shield	1/16 x 2 1/4 x 22 Metal sheeting
B	Framework	1/8 x 1 x Angle iron throughout	G	Ignition Transformer	115 V, 60 Hz, 5000 V, 20 A secondary
C	Side and Front Panels	1/4 Transite or Chem-Fil 100S or 100 H ⁸ cut to specifications	H	Spark Switch	Push button type
D	Side Glass	1/8 x 2 x 24 Polished Vycor cut as shown	I	Ceramic Insulator	
E	Burner	Artificial Gas Model	J	Spark Wire	1/16 OD Nichrome
	Gas Control Valve (not shown)	1/8 Orifice, 1" Pipe size, outlet 3 oz/in ²	K	Thermocouple	Megopak Type J, totally shielded
	Gage, Gas (not shown)	0-30 oz/in ² Dial		Recording Potentiometer	115 V, 60 Hz, 0-300°C, Type J concl

Note: All Dimensions Expressed in Inches Unless Otherwise Noted.

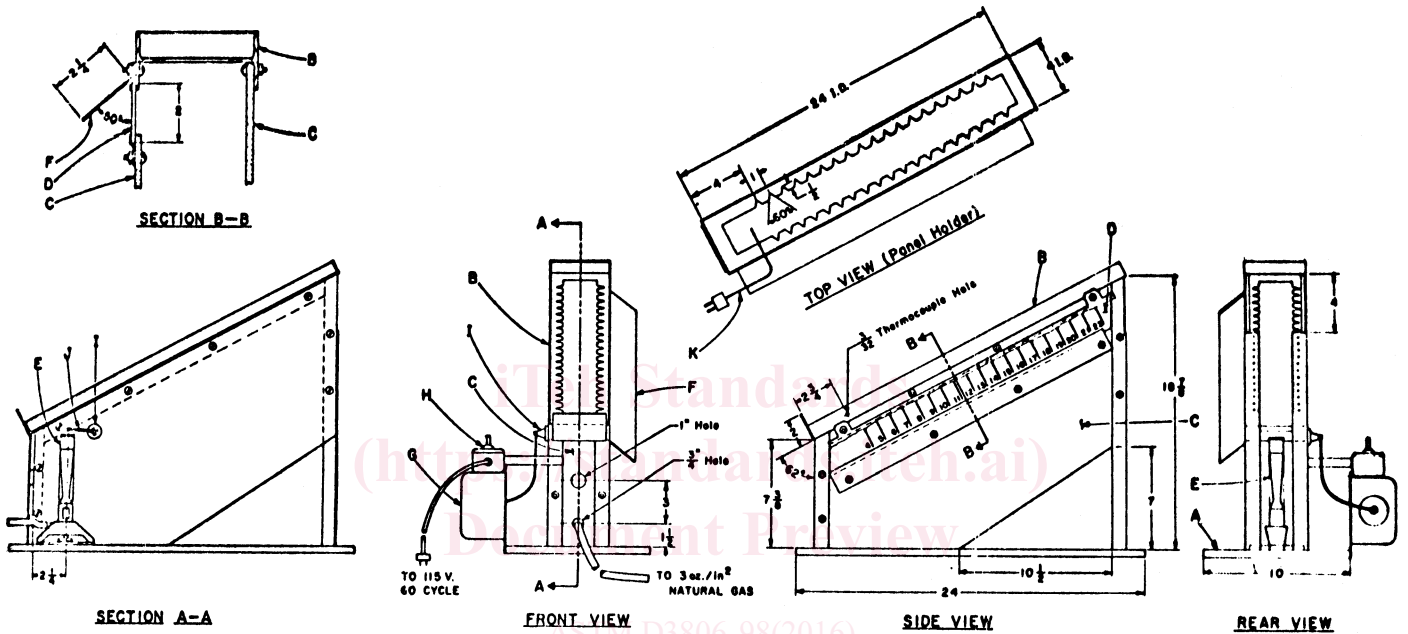

METRIC EQUIVALENTS

in.	mm	in.	mm
1/16	1.6	3	76
3/32	2.4	4	102
1/8	3.2	7	178
1/4	6.4	7 3/8	187
1/2	12.7	10	254
1	25.4	10 1/2	267
1 1/2	38	18 3/8	480
2 1/4	57	22	560
2 3/4	70	24	610

FIG. 1 Flame Tunnel