



Designation: D8079 – 16

Standard Practice for Preparation of Compacted Slab Asphalt Mix Samples Using a Segmented Rolling Compactor¹

This standard is issued under the fixed designation D8079; the number immediately following the designation indicates the year of original adoption or, in the case of revision, the year of last revision. A number in parentheses indicates the year of last reapproval. A superscript epsilon (ϵ) indicates an editorial change since the last revision or reapproval.

1. Scope

1.1 This practice covers the fabrication of slabs of asphalt mix using an automated laboratory rolling compactor (RC). Compacted specimens are suitable for volumetric and physical property testing. This practice should not be used for acceptance or rejection of a material or for purchasing purposes.

1.2 Units—The values stated in SI units are to be regarded as standard. No other units of measurement are included in this standard.

1.3 The text of this standard references notes and footnotes which provide explanatory material. These notes and footnotes (excluding those in tables and figures) shall not be considered as requirements of the standard.

1.4 *This standard does not purport to address all of the safety concerns, if any, associated with its use. It is the responsibility of the user of this standard to establish appropriate safety and health practices and determine the applicability of regulatory limitations prior to use.*

2. Referenced Documents

- 2.1 *ASTM Standards:*²
- D979/D979M Practice for Sampling Bituminous Paving Mixtures
 - D1188 Test Method for Bulk Specific Gravity and Density of Compacted Bituminous Mixtures Using Coated Samples
 - D2041 Test Method for Theoretical Maximum Specific Gravity and Density of Bituminous Paving Mixtures
 - D2726 Test Method for Bulk Specific Gravity and Density of Non-Absorptive Compacted Bituminous Mixtures
 - D3666 Specification for Minimum Requirements for Agencies Testing and Inspecting Road and Paving Materials
 - D6752 Test Method for Bulk Specific Gravity and Density

¹ This practice is under the jurisdiction of ASTM Committee D04 on Road and Paving Materials and is the direct responsibility of Subcommittee D04.20 on Mechanical Tests of Asphalt Mixtures.

Current edition approved Dec. 1, 2016. Published December 2016. DOI: 10.1520/D8079-16.

² For referenced ASTM standards, visit the ASTM website, www.astm.org, or contact ASTM Customer Service at service@astm.org. For *Annual Book of ASTM Standards* volume information, refer to the standard's Document Summary page on the ASTM website.

- of Compacted Bituminous Mixtures Using Automatic Vacuum Sealing Method
- D6857 Test Method for Maximum Specific Gravity and Density of Bituminous Paving Mixtures Using Automatic Vacuum Sealing Method
- D7460 Test Method for Determining Fatigue Failure of Compacted Asphalt Concrete Subjected to Repeated Flexural Bending
- E644 Test Methods for Testing Industrial Resistance Thermometers
- 2.2 *AASHTO Standards:*³
 - AASHTO T 321 Method of Test for Determining the Fatigue Life of Compacted Asphalt Mixtures Subjected to Repeated Flexural Bending
 - AASHTO T 324 Method of Test for Hamburg Wheel-Track Testing of Compacted Hot Mix Asphalt (HMA)
 - AASHTO M 323 Specification for Superpave Volumetric Mix Design
- 2.3 *Additional Resources:*⁴
 - Asphalt Institute MS-2 Asphalt Mix Design Methods

3. Terminology

3.1 Definitions:

3.1.1 *rolling compactor*—a device that uses a segment or arc of a circle composed of metal to compact asphalt mixture into a slab.

3.1.2 *rolling compactor foot*—the portion of the device that consists of the segment or arc of a circle composed of metal attached to the loading frame that rotates across the surface of the asphalt mixture.

3.1.3 *rolling compactor tray*—the portion of the device that the mold rests on during compaction. The tray can be stationary or can move horizontally to facilitate compaction.

3.2 Definitions of Terms Specific to This Standard:

3.2.1 *lab mix lab compacted (LMLC) asphalt mix*—asphalt mix samples that are prepared in the laboratory by weighing

³ Available from American Association of State Highway and Transportation Officials (AASHTO), 444 N. Capitol St., NW, Suite 249, Washington, DC 20001, <http://www.transportation.org>.

⁴ Available from Asphalt Institute at: <http://bookstore.asphaltinstitute.org/catalog/book/ms-2-asphalt-mix-design-methods>.

and blending each constituent and then compacting the blended mix using a laboratory compaction apparatus.

3.2.1.1 *Discussion*—LMLC typically occurs during the asphalt mix design phase.

3.2.2 *plant mix laboratory compacted (PMLC) asphalt mix*—asphalt mix samples that are manufactured in a production plant, sampled prior to compaction, then immediately compacted using a laboratory compaction apparatus.

3.2.2.1 *Discussion*—PMLC specimens are often used for quality control testing. Asphalt mix is not permitted to cool substantially and it may be necessary to place the mix in a laboratory oven to equilibrate the mix to the compaction temperature before molding.

3.2.3 *reheated plant mix lab compacted (RPMLC) asphalt mix*—asphalt mix samples that are manufactured in a production plant, sampled prior to compaction, allowed to cool to room temperature, then reheated in a laboratory oven and compacted using a laboratory compaction apparatus.

3.2.3.1 *Discussion*—RPMLCs are often used for quality acceptance and verification testing. The reheating time should be as short as possible to obtain uniform temperature to avoid artificially aging the specimens. Asphalt mix conditioning, reheat temperature, and time should be defined in the applicable specification.

4. Summary of Practice

4.1 A sample of loose asphalt mix is compacted in an automatic apparatus by the combination of vertical displacements of a segmented rolling compactor foot and horizontal movements of a rolling compactor foot relative to the compactor tray to produce a slab of compacted asphalt with a target theoretical density (that is, based on the geometric volume of the specimen).

5. Significance and Use

5.1 Asphalt slabs compacted with the rolling compactor can be used to obtain specimens for further testing, including bulk specific gravity following Test Methods D1188, D2726, and D6752, fatigue performance characteristics following Test Method D7460 or AASHTO T 321, and Hamburg wheel-track testing following AASHTO T 324.

5.2 Specimens to perform other standard tests could also be obtained, as long as their volume is contained within the volume of a slab.

NOTE 1—The quality of the results produced by this standard are dependent on the competence of the personnel performing the procedure and the capability, calibration, and maintenance of the equipment used. Agencies that meet the criteria of Specification D3666 are generally considered capable of competent and objective testing, sampling, inspection, etc. Users of this practice are cautioned that compliance with Specification D3666 alone does not completely ensure reliable results. Reliable results depend on many factors following the suggestions of Specification D3666 or some similar acceptable guideline that provides a means of evaluating and controlling some of those factors.

6. Apparatus

6.1 *Segmented Rolling Compactor*—A compactor capable of fabricating asphalt slabs comprised of the following system

components: (1) reaction frame, (2) fully integrated loading system, including loading rams, controller, and data acquisition to record loads applied, height measurements, and number of cycles, and (3) segmented rolling compactor foot and mold. The compactor must comply with the following specifications:

6.1.1 Vertical load divided by the width of the mold perpendicular to the rolling direction is adjustable by the user up to at least 75 kg/cm.

NOTE 2—The vertical load should be measured and controlled to an accuracy of $\pm 5\%$ of the applied load. The loading system used to achieve the required load can be electromechanical, pneumatic, or hydraulic.

6.1.2 The capability to perform at least four load cycles every minute.

6.1.3 The compactor must be capable of producing compacted slabs with minimum dimensions of 300 ± 5 mm long, 260 ± 5 mm wide, and with a minimum height measured at the center of the slab of 38 mm.

6.1.4 The controller must also be capable of automatically terminating the compaction run after meeting one of three termination criteria: sample height, number of loading cycles, or target density. The controller shall state that the compaction is finished and the termination criterion (height, cycles, or theoretical density) shall be recorded.

NOTE 3—Since the dimensions of the mold and the mass of the mixture are known, the theoretical density can be calculated.

6.1.5 The reaction frame shall be rigid and capable of sustaining the maximum forces generated during the compaction process. It shall also be able to sustain the reaction forces being applied to the mold.

6.1.6 The loading system (see Fig. 1) shall consist of a

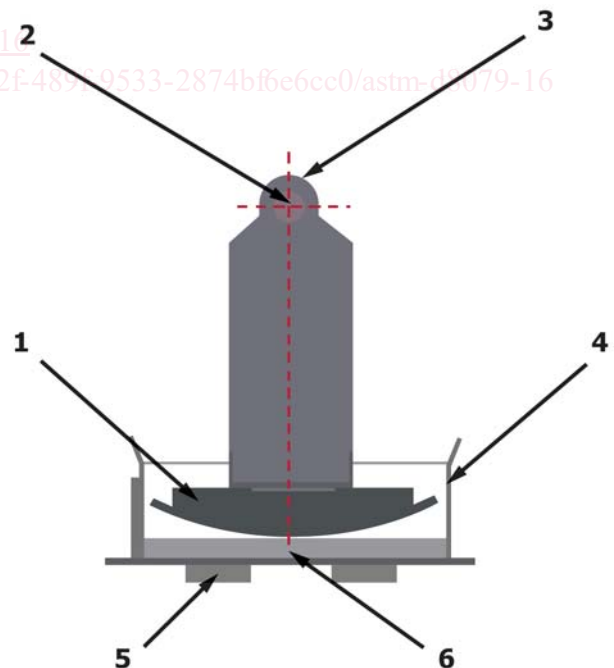

- | | |
|---------------------------|---------------------------|
| 1. Rolling compactor foot | 4. Mold |
| 2. Pivot | 5. Rolling compactor tray |
| 3. Linear loading point | 6. Sample |

FIG. 1 Example Schematic of a Rolling Compactor