



Designation: D6914/D6914M – 16

Standard Practice for Sonic Drilling for Site Characterization and the Installation of Subsurface Monitoring Devices¹

This standard is issued under the fixed designation D6914/D6914M; the number immediately following the designation indicates the year of original adoption or, in the case of revision, the year of last revision. A number in parentheses indicates the year of last reapproval. A superscript epsilon (ϵ) indicates an editorial change since the last revision or reapproval.

1. Scope*

1.1 This practice covers procedures for using sonic drilling methods in the conducting of subsurface exploration for site characterization and in the installation of subsurface monitoring devices.

1.2 The use of the sonic drilling method for exploration and monitoring-device installation may often involve preliminary site research and safety planning, administration, and documentation.

1.3 Soil or Rock samples collected by sonic methods are classed as group A or group B in accordance with Practices D4220. Other sampling methods (Guide D6169) may be used in conjunction with the sonic method to collect samples classed as group C and Group D. Other drilling methods are summarized in Guide D6286.

1.4 *Units*—The values stated in either inch-pound units or SI units [presented in brackets] are to be regarded separately as standard. The values stated in each system may not be exact equivalents; therefore, each system shall be used independently of the other. Combining values from the two systems may result in non-conformance with the standard. Reporting of test results in units other than in-pound shall not be regarded as nonconformance with this practice.

1.5 All observed and calculated values shall conform to the guidelines for significant digits and rounding established in Practice D6026, unless superseded by this standard.

1.6 This practice offers a set of instructions for performing one or more specific operations. It is a description of the present state-of-the-art practice of sonic drilling. It does not recommend this method as a specific course of action. This document cannot replace education or experience and should be used in conjunction with professional judgment. Not all aspects of this practice may be applicable in all circumstances. This ASTM standard is not intended to represent or replace the

standard of care by which the adequacy of a given professional service must be judged, nor should this document be applied without consideration of a project's many unique aspects. The word "Standard" in the title of this document means only that the document has been approved through the ASTM consensus process.

1.6.1 This practice does not purport to comprehensively address all the methods and the issues associated with drilling practices. Users should seek qualified professionals for decisions as to the proper equipment and methods that would be most successful for their site investigation. Other methods may be available for drilling and sampling of soil, and qualified professionals should have the flexibility to exercise judgment as to possible alternatives not covered in this practice. This practice is current at the time of issue, but new alternative methods may become available prior to revisions, therefore, users should consult manufacturers or sonic drilling services providers prior to specifying program requirements.

1.7 *This practice does not purport to address all the safety concerns, if any, associated with its use and may involve use of hazardous materials, equipment, and operations. It is the responsibility of the user of this standard to establish appropriate safety and health practices and determine the applicability of regulatory requirements prior to use.* For good safety practice, consult applicable OSHA regulations and drilling safety guides.^{2,3,4}

2. Referenced Documents⁵

- 2.1 *ASTM Standards—Soil Classification:*
D653 Terminology Relating to Soil, Rock, and Contained Fluids
D2113 Practice for Rock Core Drilling and Sampling of Rock for Site Exploration

² "Drilling Safety Guide," National Drilling Association.

³ "Drillers Handbook," Thomas C. Ruda and Peter Bosscher, National Drilling Association.

⁴ "Innovative Technology Summary Report," April 1995, U.S. Department of Energy.

⁵ For referenced ASTM standards, visit the ASTM website, www.astm.org, or contact ASTM Customer Service at service@astm.org. For *Annual Book of ASTM Standards* volume information, refer to the standard's Document Summary page on the ASTM website.

¹ This practice is under the jurisdiction of ASTM Committee D18 on Soil and Rock and is the direct responsibility of Subcommittee D18.21 on Groundwater and Vadose Zone Investigations.

Current edition approved Nov. 15, 2016. Published December 2016. Originally approved in 2004. Last previous edition approved in 2010 as D6914–04(2010). DOI: 10.1520/D6914_D6914M-16.

*A Summary of Changes section appears at the end of this standard

D2488 Practice for Description and Identification of Soils (Visual-Manual Procedures)

D5434 Guide for Field Logging of Subsurface Explorations of Soil and Rock (Withdrawn 2021)⁶

2.2 *ASTM Standards—Drilling Methods and Installation Methods:*

D1452 Practice for Soil Exploration and Sampling by Auger Borings

D5088 Practice for Decontamination of Field Equipment Used at Waste Sites

D5299 Guide for Decommissioning of Groundwater Wells, Vadose Zone Monitoring Devices, Boreholes, and Other Devices for Environmental Activities

D5791 Guide for Using Probability Sampling Methods in Studies of Indoor Air Quality in Buildings

D5782 Guide for Use of Direct Air-Rotary Drilling for Geoenvironmental Exploration and the Installation of Subsurface Water-Quality Monitoring Devices

D5783 Guide for Use of Direct Rotary Drilling with Water-Based Drilling Fluid for Geoenvironmental Exploration and the Installation of Subsurface Water-Quality Monitoring Devices

D5784 Guide for Use of Hollow-Stem Augers for Geoenvironmental Exploration and the Installation of Subsurface Water Quality Monitoring Devices

D6286 Guide for Selection of Drilling and Direct Push Methods for Geotechnical and Environmental Subsurface Site Characterization

2.3 *ASTM Standards—Soil Sampling:*

D1586 Test Method for Standard Penetration Test (SPT) and Split-Barrel Sampling of Soils

D1587 Practice for Thin-Walled Tube Sampling of Fine-Grained Soils for Geotechnical Purposes

D3550 Practice for Thick Wall, Ring-Lined, Split Barrel, Drive Sampling of Soils

D4220 Practices for Preserving and Transporting Soil Samples

D4700 Guide for Soil Sampling from the Vadose Zone

D6169 Guide for Selection of Soil and Rock Sampling Devices Used With Drill Rigs for Environmental Investigations

D6640 Practice for Collection and Handling of Soils Obtained in Core Barrel Samplers for Environmental Investigations

2.4 *ASTM Standards—Aquifer Testing:*

D4044 Test Method for (Field Procedure) for Instantaneous Change in Head (Slug) Tests for Determining Hydraulic Properties of Aquifers

D4050 Test Method for (Field Procedure) for Withdrawal and Injection Well Testing for Determining Hydraulic Properties of Aquifer Systems

D5092 Practice for Design and Installation of Groundwater Monitoring Wells

2.5 *ASTM Standards—Other:*

D3740 Practice for Minimum Requirements for Agencies Engaged in Testing and/or Inspection of Soil and Rock as

Used in Engineering Design and Construction

D6026 Practice for Using Significant Digits in Geotechnical Data

3. Terminology

3.1 *Definitions:*

3.1.1 For common definitions of technical terms in this standard refer to Terminology **D653**.

3.2 *Definitions of Terms Specific to This Standard:*

3.2.1 *hydraulic extraction, n*—the removal of the sample specimen from the solid sampling barrel by the application of fluid.

3.2.2 *natural frequency, n*—the frequency or frequencies at which an object tends to vibrate when disturbed.

3.2.3 *resonance, n*—when one object (sine generator) vibrating at the natural frequency of a second object (drill pipe or casing) forces the second object into vibrational motion.

3.2.4 *sine wave generator, n*—a drill head that imparts forces in wave forms corresponding to single-frequency periodic oscillations to create resonance of the drill rods and casings to advance the drill hole.

3.2.4.1 *Discussion*—This drill head is referred to as a sonic drill head, or resonant sonic drill head throughout this standard. This drill head is attached to the drill rods and casings and can be used to lift rods for sample extrusion.

3.2.5 *sonic drilling, n*—the practice of using high frequency vibration as the primary force to advance drill tools through subsurface formations.

3.2.5.1 *Discussion*—While vibration is the primary force for drilling, the drilling process also requires rotation of the drill rods with applied downforce reaction from the drill

4. Summary of Practice

4.1 Sonic drilling is the utilization of high frequency vibration aided by down pressure and rotation to advance drilling tools through various subsurface formations. All objects have a natural frequency or set of frequencies at which they will vibrate when disturbed. The natural frequency is dependent upon the properties of the material the object is made of and the length of the object. The sonic drill head provides the disturbance to the drilling tools causing them to vibrate. To achieve penetration of the formation the strata is fractured, sheared, or displaced. The high frequency vibration can cause the soil in contact with the drill bit and drilling casing string to liquefy and flow away allowing the casing to pass through with reduced friction. Rotation of the drill string is primarily for even distribution of the applied energy, to control bit wear, and to help maintain borehole alignment. The use of vibratory technology reduces the amount of drill cuttings, provides rapid formation penetration, and the recovery of a continuous core sample of formation specimens for field analysis and laboratory testing. Boreholes generated by sonic drilling can be fitted with various subsurface condition monitoring devices. Numerous sampling techniques can also be used with this system including thin walled tubes, split barrel samplers, and *in-situ* groundwater sampling devices. **Fig. 1** demonstrates the general principle of sonic drilling.

⁶ The last approved version of this historical standard is referenced on www.astm.org.

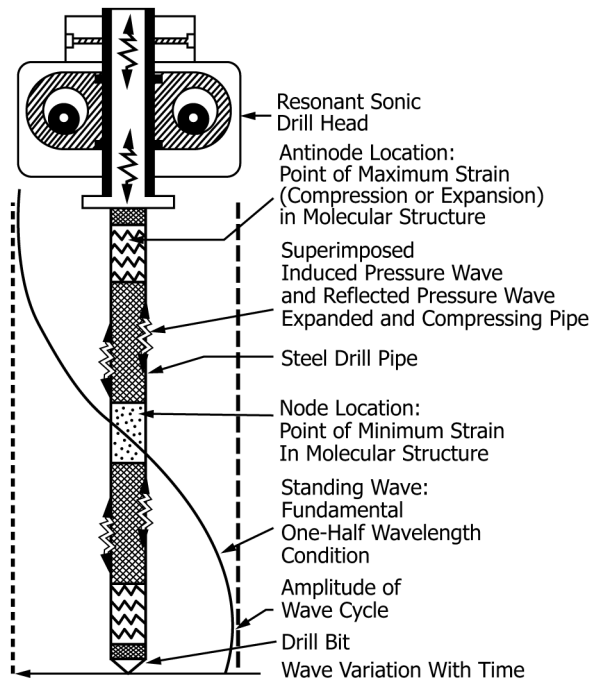

FIG. 1 General Principle of Sonic Drilling

5. Significance and Use

5.1 Sonic drilling is a rapid, primarily dry drilling method (see 5.2), used both in geotechnical applications to avoid hydraulic fracturing, and in environmental site exploration. Geotechnical applications include exploration for tunnels, underground excavations, and installation of instrumentation or structural elements. Sonic drilling methods are used in rocky soils with large diameter casing to obtain continuous samples in materials that are difficult to sample using other methods. It is well suited for projects of a production-orientated nature with a drilling rate faster than most all other drilling methods (Guide D6286). Sonic drilling is used for environmental explorations because sonic drilling offers the benefit of significantly reduced drill cuttings, a major cost element, and reduced drill fluid use and production. Sonic drilling offers rapid formation penetration thereby increasing production. It can reduce fieldwork time generating overall project cost reductions. The continuous core sample recovered provides a representative lithological column for review and analysis. Sonic drilling readily lends itself to environmental instrumentation installation and to *in-situ* testing. The advantage of a clean cased hole without the use of drilling fluids provides for increased efficiency in instrumentation installation. The ability to cause vibration to the casing string eliminates the complication of monitoring well backfill bridging common to other drilling methods and reduces the risk of casing lockup allowing for easy casing withdrawal during grouting. The clean borehole reduces well development time. Pumping tests can be performed as needed prior to well screen placement to allow for proper screen location. The sonic method is readily utilized in multiple cased well applications which are required to prevent aquifer cross contamination. The installation of inclinometers,

vibrating wire piezometers, settlement gauges, and the like can be accomplished efficiently with the sonic method.

5.2 The cutting action, as the sonic drilling bit passes through the formation, may cause disturbance to the soil structure along the borehole wall. The vibratory action of directing the sample into the sample barrel and then vibrating it back out can cause distortion of the specimen. Core samples can be hydraulically extracted from the sample barrel to reduce distortion. The use of split barrels, with or without liners, may improve the sample condition but may not completely remove the vibratory effect. When penetrating rock formations, the vibration may create mechanical fractures that can affect structural analysis for permeability and thereby not reflect the true *in-situ* condition. Sonic drilling in rock will require the use of air or fluid to remove drill cuttings from the face of the bit, as they generally cannot be forced into the formation. Samples collected by the dry sonic coring method from dense, dry, consolidated or cemented formations may be subjected to drilling induced heat, which could be a concern if core sampling for volatile organic compounds using Practice D6640. Heat is generated in these dry formations by the impact of the bit on the formation and the friction created when the core barrel is forced into the formation. The sampling barrel is advanced without drilling fluid whenever possible. Therefore, in very dense formations, drilling fluids may have to be used to remove drill cuttings from the bit face and to control drilling generated heat. In dry, dense formations precautions to control drilling generated heat may be necessary to avoid affecting contaminant presence. The effects of drilling generated heat can be mitigated by shortening sampling runs, changing vibration level and rotation speed, using cooled sampling barrels, collecting larger diameter samples to reduce effect on

the interior of the sample, and using fluid coring methods or by using alternate sampling methods such as the standard penetration test type samplers at specific intervals. Heat generated while casing the borehole through dense formations after the core sample has been extracted can be alleviated by potable water injection and/or by using crowd-in casing bits that shear the formation with minimal resistance. Should borehole wall densification be a concern it can be alleviated by potable water injection, by borehole wall scraping with the casing bit, by using a crowd-in style bit, or by injecting natural clay break-down compounds.

5.3 Other uses for the sonic drilling method include mineral investigations. Bulk samples can be collected continuously, quite rapidly, in known quantities to assess mineral content. Aggregate deposits can be accurately defined by using large diameter continuous core samplers that gather representative samples. A limited amount of rock can be effectively penetrated and crushability determined. In construction, projects include freeze tube installations for deep tunnel shafts, piezometers, small diameter piles, dewatering wells, foundation anchors with grouting, and foundation movement monitoring instrumentation. Sonic drills can be used to set potable water production wells. However, production may not equal more conventional potable well drilling techniques because of the need to transport drill cuttings to the surface in short increments. Sonic drill units presently in use are in various sizes and most are truck mounted. Sonic drills can be skid or all-terrain vehicle mounted to access difficult areas.

5.4 Sonic drills can be adapted to such other drill methods as conventional rotary (Guide D1583, Guide D5782), down hole air hammer work (Guide D5782), diamond bit rock coring; conventional and wireline (Practice D2113), direct push probing (Guide D6001, Guide D6286), thin wall tube sampling (Practice D1587), and standard penetration test split barrel sampling (Practice D1586). The sonic drilling equipment offers more adaptability than most existing drilling systems. However, it is important to keep in mind that the technique the machine is designed for is the one at which it will be the most efficient. Long term use of sonic drills for other drilling methods may not be cost effective.

NOTE 1—The quality of the result produced by this standard is dependent on the competence of the personnel performing it, and the suitability of the equipment and facilities used. Agencies that meet the criteria of Practice D3740 are generally considered capable of competent and objective testing/sampling/inspection/etc. Users of this standard are cautioned that compliance with Practice D3740 does not in itself assure reliable results. Reliable results depend on many factors; Practice D3740 provides a means of evaluating some of those factors. Practice D3740 was developed for agencies engaged in the testing and/or inspection of soils and rock. As such, it is not totally applicable to agencies performing this practice. However, user of this practice should recognize that the framework of Practice D3740 is appropriate for evaluating the quality of an agency performing this practice. Currently there is no known qualifying national authority that inspects agencies that perform this practice.

6. Criteria for Selection

6.1 Important criteria to consider when selecting the sonic drilling method include the following:

6.1.1 Diameter of borehole,

6.1.2 Sample quality (Class A, B) for laboratory physical testing (Refer to Practices D4220),

6.1.3 Sample handling requirements such as containers, preservation requirements,

6.1.4 Subsurface conditions anticipated: soil type or rock type/hardness,

6.1.5 Groundwater depth anticipated,

6.1.6 Boring depth,

6.1.7 Instrumentation requirements,

6.1.8 Chemical composition of soil and contained pore fluids,

6.1.9 Available funds,

6.1.10 Estimated cost,

6.1.11 Time constraints,

6.1.12 History of method performance under anticipated conditions (consult experienced users and manufacturers),

6.1.13 Site accessibility,

6.1.14 Decontamination requirements,

6.1.15 Grouting requirements, local regulations, and

6.1.16 Amount of and disposal costs for generated drill cuttings and drilling wastes.

7. Apparatus

7.1 *Sonic Drill Head*—The sonic drill head contains a sine wave generator, sine generator drive mechanism, lubrication system to reduce friction and control heat in the head, vibration isolation device, drill string rotating mechanism, and a connection to the drill string. The sine wave generator must be capable of producing sufficient energy to force movement in the drill string to accomplish the fracturing, shearing or displacement necessary for the borehole to be advanced as shown in Fig. 1.

7.1.1 *Sine Wave Generator*—The sine wave generator uses eccentric, counter rotating balance weights that are timed to direct 100 percent of the vibration at 0 degrees and at 180 degrees (Figs. 2 and 3). The sine wave generator is powered hydraulically and generally operates at frequencies between 0 and 185 Hz delivering a full range of energy outputs for advancement of up to 12 in. [300 mm] drill casing.

7.1.2 *Lubrication System*—The lubrication system is fitted with oil coolers of sufficient capacity to keep the hydraulic fluid at an allowable operating range as recommended by the oil supplier.

7.1.3 *Vibration Isolation System*—In order to transmit the maximum vibratory energy to the drill string and not damage the drilling rig the vibration applied to the drill tools must be isolated from the drill rig as shown in Figs. 2 and 3. This can be accomplished by using air charged springs, manual disk springs, or such other methods as will meet that goal.

7.2 *Drilling Tools*—A significant variety of tooling is necessary to accomplish the sonic drilling program. The tools consist of drill rods, drill casing, sampler barrels, sampler bits, casing bits, direct push sampling probes, borehole water sample collection systems, etc. Individual drillers and companies have in-house tooling designed for specific purposes and projects. If these specialized tools provide high quality sampling and efficient drilling processes they are acceptable to the practice.

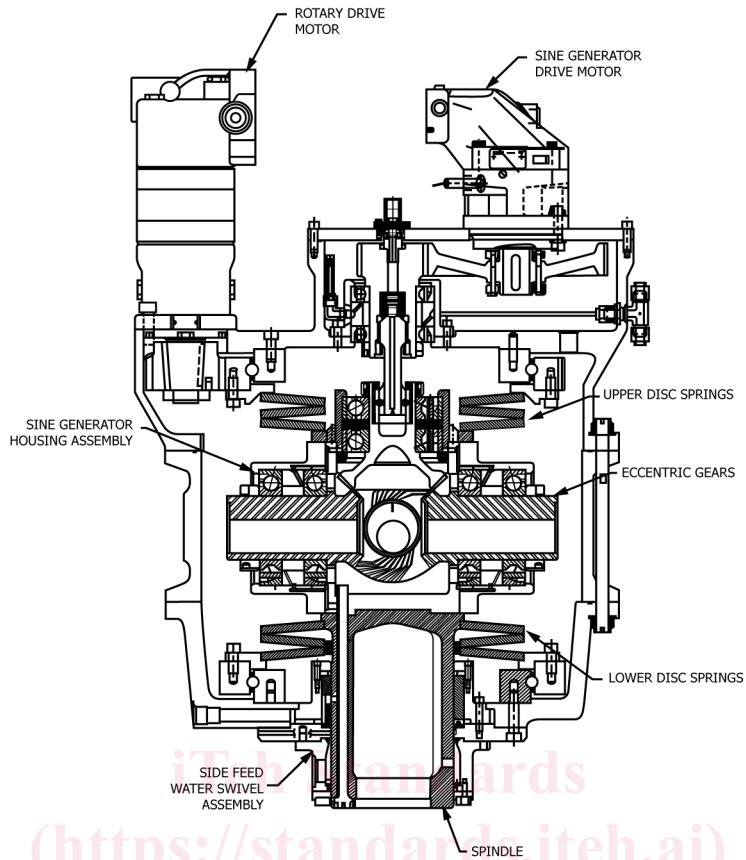

FIG. 2 Typical Sonic Drill Head with Disk Spring Form of Isolation System

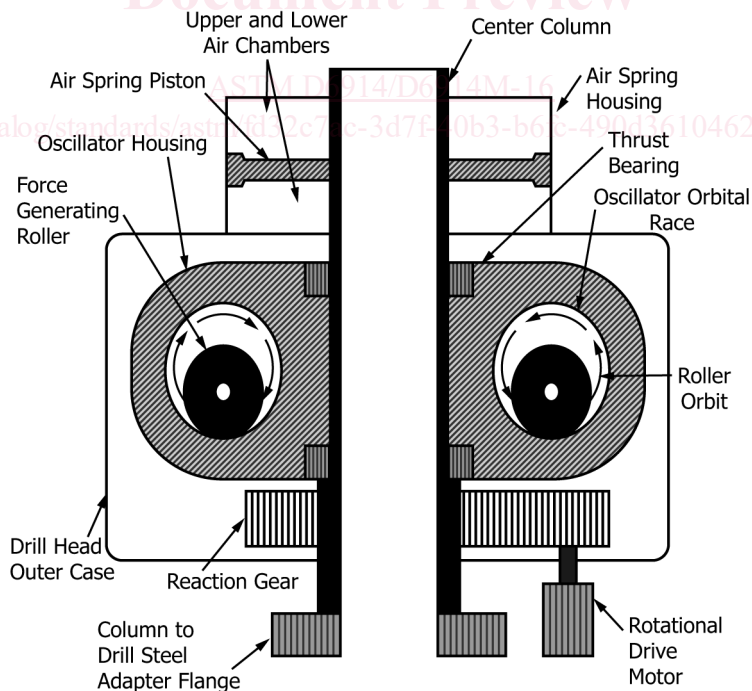

FIG. 3 Typical Sonic Drill Head with Air Spring Form of Isolation System

7.2.1 *Drilling Rods and Casing*—Drilling rods are used to propel and recover the sampling barrels. Drill rods are the most handled tools. The common sizes are 2 in. [50 mm] to 4 in.

[100 mm] diameter by 2 ft [0.5 m], 5 ft [1.5 m], 10 ft [3 m], and 20 ft [5 m] lengths. Annular space between casing and rod is not critical allowing the same sized drill rod to be used with

various sized sampling barrels. Current sonic drilling technology can be used to set drill casing in various sizes from 4 in. [100 mm] up to 12 in. [300 mm] nominal outside diameter depending on project requirements.

7.2.2 Sampler Barrel—Sampler barrels (a.k.a. core barrels) are used to recover formation specimens and to clean the inside of the drill casing. Sampler barrels are either solid tubes or split barrels of various diameters and lengths. The sampling barrels are generally sized to match the inside diameter of the various sizes of drill casing and to fulfill project requirements. The barrel is fitted with a drill bit/cutting shoe that holds the borehole alignment as it passes through the outer casing into the formation.

7.2.2.1 Solid Barrels—Solid sampler barrels are a solid length of tubing with thread sections on each end. They are available in various sizes and lengths. Typical sampling runs are 10 to 20 ft [3 to 5 m] in length. Sampling run length can be adjusted to provide the most optimum sample recovery. Sampler barrels can be joined to increase the length of sampling increment. In some formations there is a tendency to lose recovery with longer core run lengths while in others longer core runs may improve recovery. Samples of loose unconsolidated granular formations can be consolidated by the vibratory action. In loose or soft formations the inability of the soil structure to support the force necessary to move the material into the barrel can cause that material to be forced into the formation.

7.2.2.2 Split Barrel Samplers—Split barrel samplers are tubes that are split lengthwise with thread sections on both ends. The split sections utilize a tongue & groove feature that interlocks to prevent lateral movement between the two halves of the tube. Split barrel samplers are available in various diameters and lengths. While split barrel samplers provide a better format to view the specimen and may subject it to less disturbance, they do receive vibratory action during penetration. Depending on the method of construction, split barrels have a tendency to spread open in hard formations. They are quite heavy when fully loaded and may require special handling techniques. Liners, clear butyl or polyethylene based plastic, or stainless steel are available for use with split barrel and solid barrel samplers.

7.2.2.3 Standard formation sampling devices can be used in conjunction with the sonic drill rig for geotechnical applications. The standard penetration test **D1586** can be performed if the unit is equipped with a cathead or an automatic-hammer 140 lb [63.523 kg]. The hydraulically activated, D6519, as well as manual, fixed piston, thin wall tube samplers **D1587** can be

used if the unit is equipped with a fluid pump of sufficient capacity. Sonic drills are generally equipped with winch lines for using sampling tools in geotechnical drilling programs.

7.2.3 Casing Drill Bits—Drill bits are attached to the leading section of drill casing. Their function is to provide a cutting edge to assist in moving the casing through the various formations encountered and to direct the movement of formation materials during the making of the boring. The face of the drill bit follows one of three basic directional designs: (1) “Crowd-in” move most of the material encountered at the drill face into the borehole or casing as it is advanced. This style of bit face provides the best service in dense, dry, or cohesive formations as it helps reduce formation compaction and friction; (2) “Crowd-out” moves most of the material encountered at the drill face into the borehole wall. This design works better in softer and more granular, sands, gravels, and silt formations; and (3) “Neutral” allows the bit face material to choose the path of least resistance. Different bit face configurations are used to effectively penetrate different formations. The general-purpose bit face is fitted with carbide buttons spaced equally across and around the bit face. **Fig. 4** shows a typical carbide button faced bit. The carbide buttoned bit works well in most formations and is considered a general-purpose bit. Carbide buttons are well suited for the impact action that occurs in sonic drilling. Other configurations include welded carbide chips and blocks in a matrix, saw tooth shapes both hard surfaced and plain, and tearing shoe designs with large irregular carbides for working in construction debris and penetrating refuse in landfills. Each of these designs has a useful purpose and can be quite effective at penetrating their respective formations.

7.2.4 Sample Barrel Bit—The sample barrel bit is designed to both penetrate the formation and to shape the sample so it will pass through the bit into the sample barrel with the least amount of friction or compression. The bit may be constructed with serrated, carbide buttoned, or some other form of roughened inside diameter surface, or with a machined space for a retainer basket to assist in the retention of the sample. The interior of the sampler bit should have a minimum inside diameter $\frac{1}{8}$ in. [3 mm] less than the inside diameter of the sampling barrel to allow the passage of the sample into the core barrel with the least amount of resistance so as to not impede recovery or create unnecessary disturbance to the sample. The cutting face of the bit used should be the design best suited to the formation being penetrated. For dense formations with cobbles and boulders a bit face with carbide buttons may be used. For soft formations a serrated face, sharpened to force the

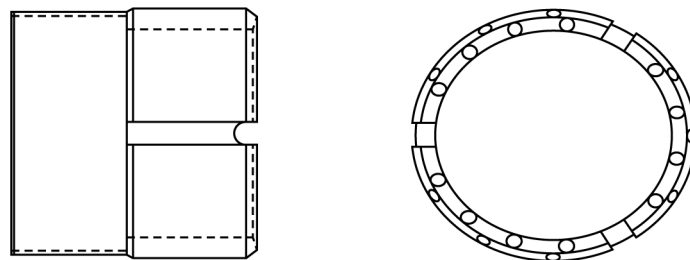

FIG. 4 Sonic Casing Bit