



Designation: D4828 – 94 (Reapproved 2016)

Standard Test Methods for Practical Washability of Organic Coatings¹

This standard is issued under the fixed designation D4828; the number immediately following the designation indicates the year of original adoption or, in the case of revision, the year of last revision. A number in parentheses indicates the year of last reapproval. A superscript epsilon (ϵ) indicates an editorial change since the last revision or reapproval.

1. Scope

1.1 These test methods cover the determination of the relative ease of removal of common soil and stains from interior coatings by manual or mechanical washing with a sponge and a liquid or powder cleanser.

1.2 The values stated in SI units are to be regarded as the standard. The values given in parentheses are for information only.

1.3 *This standard does not purport to address all of the safety concerns, if any, associated with its use. It is the responsibility of the user of this standard to establish appropriate safety and health practices and determine the applicability of regulatory limitations prior to use.*

2. Referenced Documents

2.1 *ASTM Standards:*²

D1193 Specification for Reagent Water

D3450 Test Method for Washability Properties of Interior Architectural Coatings

D3924 Specification for Environment for Conditioning and Testing Paint, Varnish, Lacquer, and Related Materials (Withdrawn 2016)³

3. Summary of Test Method

3.1 The test material is applied to a plastic panel and allowed to dry for 7 days or as mutually agreed. Soilants or stains, or both, are applied to the film. The film is washed for up to 100 cycles using a sponge and a liquid or powder cleanser. After rinsing and drying, the panel is evaluated for the degree of soil or stain removal, erosion, and any change in gloss/sheen or color between the washed and unwashed area.

¹ These test methods are under the jurisdiction of ASTM Committee D01 on Paint and Related Coatings, Materials, and Applications and are the direct responsibility of Subcommittee D01.42 on Architectural Coatings.

Current edition approved Dec. 1, 2016. Published December 2016. Originally approved in 1988. Last previous edition approved in 2012 as D4828 – 94 (2012) ^{ϵ 1}. DOI: 10.1520/D4828-94R16.

² For referenced ASTM standards, visit the ASTM website, www.astm.org, or contact ASTM Customer Service at service@astm.org. For *Annual Book of ASTM Standards* volume information, refer to the standard's Document Summary page on the ASTM website.

³ The last approved version of this historical standard is referenced on www.astm.org.

4. Significance and Use

4.1 Interior architectural paints are subjected in use to soiling by dirt or other stains. This test method provides a way to assess relative ease of soil or stain removal from a paint film using materials common to households. This test method includes a way to evaluate the film for washability properties and changes in appearance. Thus, a formulator may evaluate the effects of composition on the washability properties of a paint. Users may also compare the ease of soil removal from different paints that are tested, preferably at the same time.

5. Apparatus

5.1 *Sponge and Holder.*

5.2 *Soil and Stain Applicator* (see Fig. 1).

5.3 *Weight*, 100 g.

5.4 *Balance*, weighing accurately to 0.1 g.

5.5 *Wet Film Applicator*, capable of applying a wet film of 0.9 mm (3.5 mil) thick by 150 mm (6 in.) film width.

5.6 *Glass Plate*, 455 by 165 mm by 6.3 mm (17½ by 6½ by ¼ in.).

5.7 *Washability Machine.*

5.8 *Black Plastic Panels.*

5.9 *Masking Tape.*

5.10 *Straightedge*, approximately 430 mm (17 in.) in length.

5.11 *Cotton Tipped Swabs.*

5.12 *Medicine Droppers.*

5.13 *Suction Plate*, for drawdowns.

6. Reagents and Materials

6.1 *Purity of Water*—Unless otherwise indicated, references to water shall be understood to mean reagent water as defined by Type IV of Specification D1193.

6.2 *Soil and Staining Medium*—Examples found acceptable for use with this test method include, but are not limited to pencil, crayon, mercurochrome, ball-point pen, waterborne felt-tip markers, lipstick and mineral-oil-borne soilant as outlined in Test Method D3450.

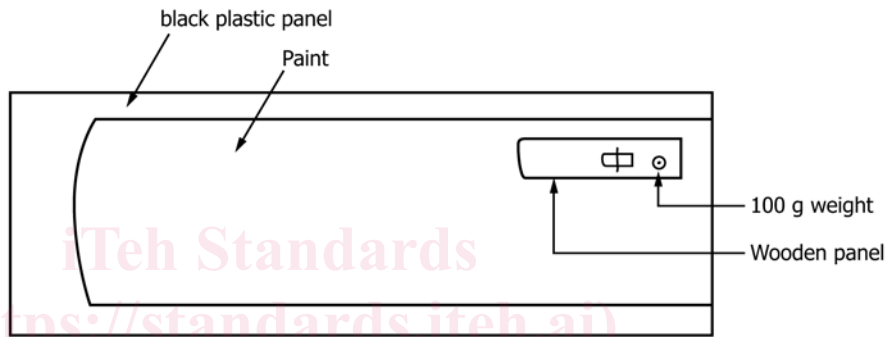
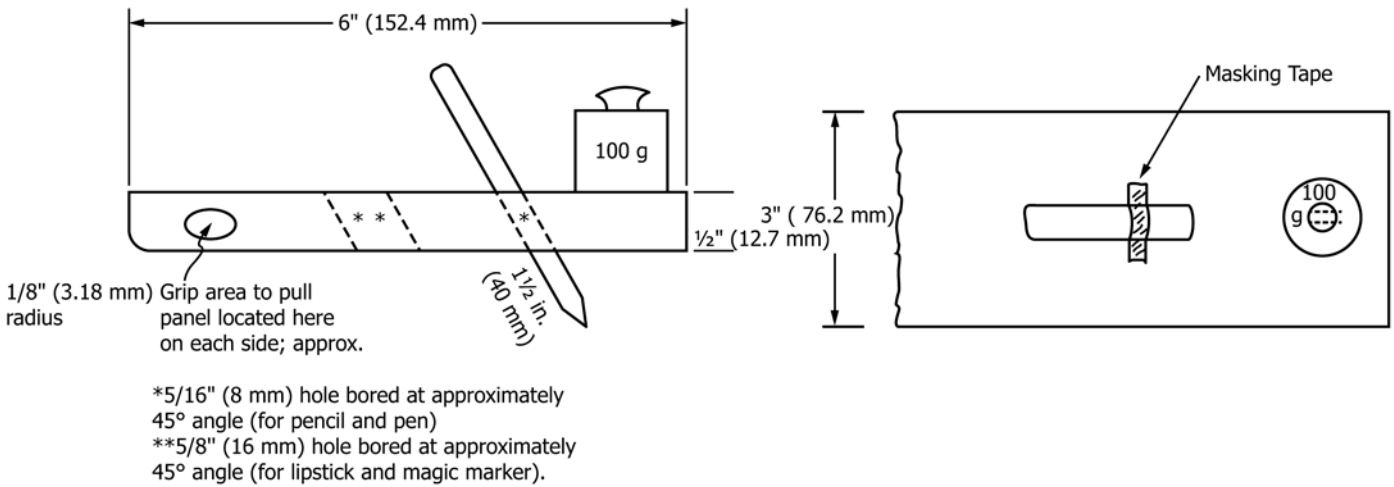

FIG. 1 Solid Soil and Stain Application

6.3 *Cleaning Media*—Examples found acceptable for use with this test method include, but are not limited to, commercial liquid cleansers, laboratory-standardized liquid cleaners as outlined in Test Method D3450, and powder cleansers. Powder cleansers containing chlorine may affect the color of the washed portion of the test panel.

7. Preparation of Apparatus

7.1 *Washability Machine*—Level the apparatus before use and operate at 37 ± 1 cpm. (A cycle consists of a complete forward and reverse stroke.)

7.2 *Sponge and Holder*—Add sufficient weight to the holder in the form of metal sheets or other flat weights to give a combined weight of 1000 g, including the dry sponge.

NOTE 1—Check the compression of the damp sponge under the 1000-g weight to ensure that the holder does not drag along the panel and tear the film.

8. Procedure

8.1 Clean the top of the glass plate and both sides of the black plastic panel to be sure they are free of specks. Place the black panel on the glass plate and tape one end to the plate. Smooth the panel along the plate to ensure a close fit.

8.2 Stir the material thoroughly and strain, if necessary, to remove all skins and particles. Draw down the coating on the panel. Apply the coating in 3 to 4 s from end to end to prevent pin holes or holidays in the film. Prepare enough panels with

each paint for all the projected tests. Air dry all panels in a horizontal position for 7 days in a room maintained at $23 \pm 2^\circ\text{C}$ ($73 \pm 3.5^\circ\text{F}$) and $50 \pm 5\%$ relative humidity as described in Specification D3924, or under conditions specifically applicable to the material under test.

NOTE 2—If desired, an extra panel of each paint may be prepared to serve as its unwashed control.

8.3 Application of Soilants and Stains:

8.3.1 At the completion of the drying period, tape the coated panel to the glass plate, as directed in 8.1, to ensure uniform application of the soilants and stains. Apply the selected soilants or stains, or both, to the coating film in straight pairs of lines parallel to the length of the panel for the manual method of cleaning, or perpendicular to the length of the panel for the mechanical method of cleaning.

8.3.2 Apply solid soilants or stains using the apparatus shown in Fig. 1. Insert pencil, crayon, pen, or similar items into the appropriately sized hole and secure its position so it extends 40 mm (1½ in.) beyond the panel (see Fig. 1(a)). Secure the medium in position with a piece of masking tape (see Fig. 1(b)). Put the applicator at one end of the coated plastic panel and place the 100-g weight on the top face of the wooden panel at the end nearest to the marking device, as shown in Fig. 1(b), securing it with a piece of tape. Allow the nonweighted end of the applicator to rest on the surface of the film, then hold it by the outer edges and pull it along the entire length of the film (see Fig. 1(c)).