



Designation: **D4828 – 94 (Reapproved 2012)^{ε1} D4828 – 94 (Reapproved 2016)**

Standard Test Methods for Practical Washability of Organic Coatings¹

This standard is issued under the fixed designation D4828; the number immediately following the designation indicates the year of original adoption or, in the case of revision, the year of last revision. A number in parentheses indicates the year of last reapproval. A superscript epsilon (ϵ) indicates an editorial change since the last revision or reapproval.

^{ε1} NOTE—Section 5.5 was editorially corrected in July 2012.

1. Scope

1.1 These test methods cover the determination of the relative ease of removal of common soil and stains from interior coatings by manual or mechanical washing with a sponge and a liquid or powder cleanser.

1.2 The values stated in SI units are to be regarded as the standard. The values given in parentheses are for information only.

1.3 *This standard does not purport to address all of the safety concerns, if any, associated with its use. It is the responsibility of the user of this standard to establish appropriate safety and health practices and determine the applicability of regulatory limitations prior to use.*

2. Referenced Documents

2.1 *ASTM Standards:*²

[D1193 Specification for Reagent Water](#)

[D3450 Test Method for Washability Properties of Interior Architectural Coatings](#)

[D3924 Specification for Environment for Conditioning and Testing Paint, Varnish, Lacquer, and Related Materials](#) (Withdrawn 2016)³

3. Summary of Test Method

3.1 The test material is applied to a plastic panel and allowed to dry for 7 days or as mutually agreed. Soilants or stains, or both, are applied to the film. The film is washed for up to 100 cycles using a sponge and a liquid or powder cleanser. After rinsing and drying, the panel is evaluated for the degree of soil or stain removal, erosion, and any change in gloss/sheen or color between the washed and unwashed area.

4. Significance and Use

4.1 Interior architectural paints are subjected in use to soiling by dirt or other stains. This test method provides a way to assess relative ease of soil or stain removal from a paint film using materials common to households. This test method includes a way to evaluate the film for washability properties and changes in appearance. Thus, a formulator may evaluate the effects of composition on the washability properties of a paint. Users may also compare the ease of soil removal from different paints that are tested, preferably at the same time.

5. Apparatus

5.1 *Sponge and Holder.*

5.2 *Soil and Stain Applicator* (see [Fig. 1](#)).

5.3 *Weight*, 100 g.

5.4 *Balance*, weighing accurately to 0.1 g.

5.5 *Wet Film Applicator*, capable of applying a wet film of 0.9 mm (3.5 mil) thick by 150 mm (6 in.) film width.

¹ These test methods are under the jurisdiction of ASTM Committee [D01](#) on Paint and Related Coatings, Materials, and Applications and are the direct responsibility of Subcommittee [D01.42](#) on Architectural Coatings.

Current edition approved July 1, 2012Dec. 1, 2016. Published August 2012December 2016. Originally approved in 1988. Last previous edition approved in 20082012 as D4828 – 94 (2008) (2012)^{ε1}. DOI: [10.1520/D4828-94R12E01](#); [10.1520/D4828-94R16](#).

² For referenced ASTM standards, visit the ASTM website, [www.astm.org](#), or contact ASTM Customer Service at [service@astm.org](#). For *Annual Book of ASTM Standards* volume information, refer to the standard's Document Summary page on the ASTM website.

³ The last approved version of this historical standard is referenced on [www.astm.org](#).

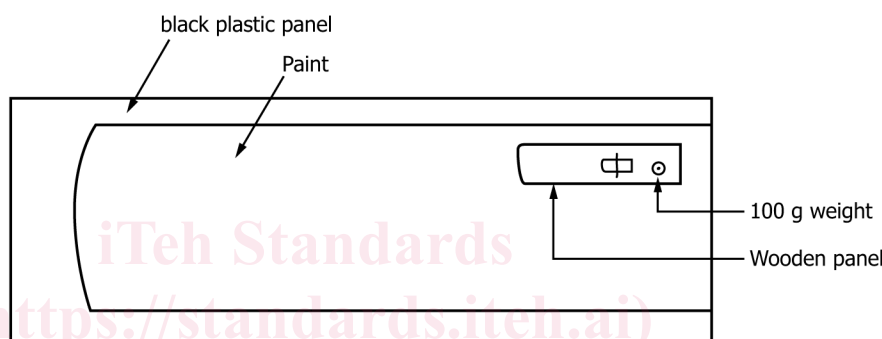
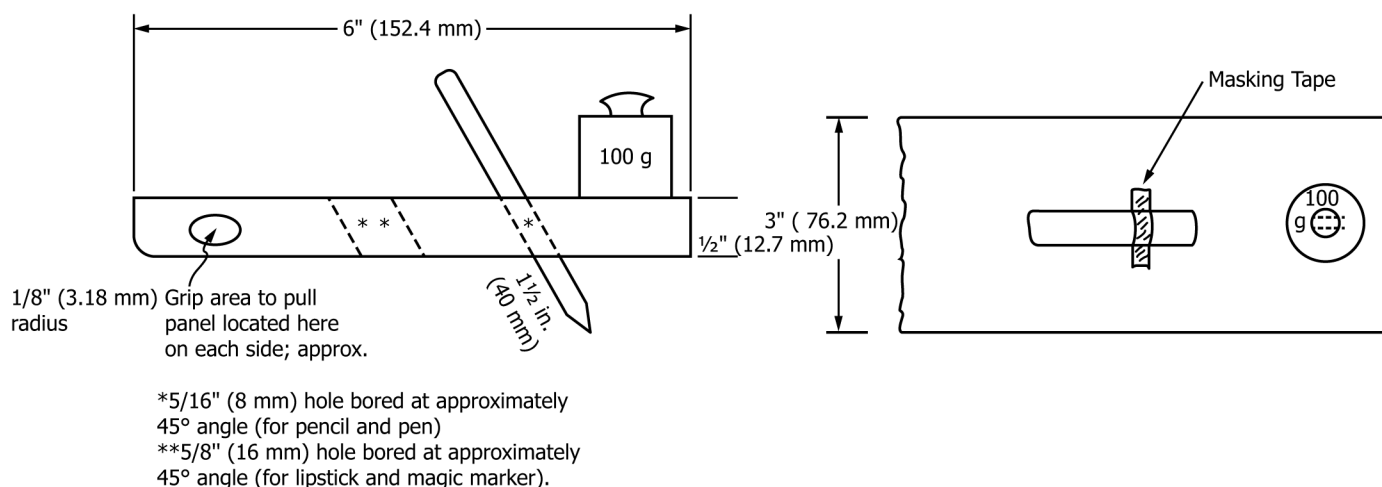

FIG. 1 Solid Soil and Stain Application

5.6 Glass Plate, 455 by 165 mm by 6.3 mm (17½ by 6½ by ¼ in.).

5.7 Washability Machine.

5.8 Black Plastic Panels.

5.9 Masking Tape.

5.10 Straightedge, approximately 430 mm (17 in.) in length.

5.11 Cotton Tipped Swabs.

5.12 Medicine Droppers.

5.13 Suction Plate, for drawdowns.

6. Reagents and Materials

6.1 *Purity of Water*—Unless otherwise indicated, references to water shall be understood to mean reagent water as defined by Type IV of Specification [D1193](#).

6.2 *Soil and Staining Medium*—Examples found acceptable for use with this test method include, but are not limited to pencil, crayon, mercurochrome, ball-point pen, waterborne felt-tip markers, lipstick and mineral-oil-borne soilant as outlined in Test Method [D3450](#).

6.3 *Cleaning Media*—Examples found acceptable for use with this test method include, but are not limited to, commercial liquid cleansers, laboratory-standardized liquid cleaners as outlined in Test Method [D3450](#), and powder cleansers. Powder cleansers containing chlorine may affect the color of the washed portion of the test panel.

7. Preparation of Apparatus

7.1 *Washability Machine*—Level the apparatus before use and operate at 37 ± 1 cpm. (A cycle consists of a complete forward and reverse stroke.)

7.2 *Sponge and Holder*—Add sufficient weight to the holder in the form of metal sheets or other flat weights to give a combined weight of 1000 g, including the dry sponge.