



# Standard Test Methods for Fire Tests of Fire-Resistive Barrier Systems for Electrical System Components<sup>1</sup>

This standard is issued under the fixed designation E1725; the number immediately following the designation indicates the year of original adoption or, in the case of revision, the year of last revision. A number in parentheses indicates the year of last reapproval. A superscript epsilon ( $\epsilon$ ) indicates an editorial change since the last revision or reapproval.

---

---

$\epsilon^1$  NOTE—Sections were rearranged editorially in December 2016.

---

---

## 1. Scope\*

1.1 These test methods cover fire-test-response.

1.2 These fire-test-response test methods provide information on the temperatures recorded on the electrical system component within a fire-resistive barrier system during the period of exposure.

1.3 *This standard is used to measure and describe the response of materials, products, or assemblies to heat and flame under controlled conditions, but does not by itself incorporate all factors required for fire hazard or fire risk assessment of the materials, products, or assemblies under actual fire conditions.*

1.4 Potentially important factors and fire characteristics not addressed by these test methods include, but are not limited to:

1.4.1 The performance of the fire-resistive barrier system constructed with components other than those tested.

1.4.2 An evaluation of the functionality of the electrical system within the fire-resistive barrier system.

1.4.3 An evaluation of the ampacity of the electrical system within the fire-resistive barrier system.

1.4.4 An evaluation of the smoke, toxic gases, corrosivity, or other products of heating.

1.4.5 A measurement of the flame spread characteristics over the surface of the fire-resistive barrier system.

1.4.6 An evaluation of through-penetration sealing methods.

1.4.7 Combustibility of materials in the fire-resistive barrier system or of the electrical system components.

1.4.8 The need for supports beyond those normally required.

1.4.9 Environmental conditions in the area of service.

1.5 The values stated in inch-pound units are to be regarded as standard. The values given in parentheses are mathematical conversions to SI units that are provided for information only and are not considered standard.

1.6 *This standard does not purport to address all of the safety concerns, if any, associated with its use. It is the responsibility of the user of this standard to establish appropriate safety and health practices and determine the applicability of regulatory limitations prior to use.*

1.7 *Fire testing is inherently hazardous. Adequate safeguards for personnel and property shall be employed in conducting these tests.*

## 2. Referenced Documents

2.1 *ASTM Standards:*<sup>2</sup>

**E119** Test Methods for Fire Tests of Building Construction and Materials

**E1529** Test Methods for Determining Effects of Large Hydrocarbon Pool Fires on Structural Members and Assemblies

## 3. Terminology

3.1 *Definitions:*

3.1.1 *air drop*—lengths of open run conductors or cables supported only at each end.

---

<sup>1</sup> These test methods are under the jurisdiction of ASTM Committee E05 on Fire Standards and are the direct responsibility of Subcommittee E05.11 on Fire Resistance. Current edition approved July 1, 2014. Published August 2014. Originally approved in 1995. Last previous edition approved in 2008 as E1725–08. DOI: 10.1520/E1725-14-10.1520/E1725-14E01.

<sup>2</sup> For referenced ASTM standards, visit the ASTM website, www.astm.org, or contact ASTM Customer Service at service@astm.org. For *Annual Book of ASTM Standards* volume information, refer to the standard's Document Summary page on the ASTM website.

\*A Summary of Changes section appears at the end of this standard

3.1.2 *electrical system components*—cable trays, conduits and other raceways, open run cables and conductors, cables, conductors, cabinets, and other components, as defined or used in the National Electrical Code, and air drops as defined in 3.1.1.

3.1.3 *fire-resistive barrier system*—a specific construction of devices, materials, or coatings installed around, or applied to, the electrical system components.

3.1.4 *specimen*—a construction consisting of electrical system components and a fire-resistive barrier system.

3.1.5 *test assembly*—horizontal or vertical construction on which test specimens are to be mounted together with associated instrumentation.

#### 4. Significance and Use

4.1 These fire-test-response test methods evaluate, under the specified test conditions, the ability of a fire-resistive barrier system to inhibit thermal transmission to the electrical system component within.

4.2 In these procedures, the specimens are subjected to one or more specific sets of laboratory test conditions. If different test conditions are substituted or the end-use conditions are changed, it is not always possible by or from these test methods to predict changes in the fire test response characteristics measured. Therefore, the results are valid only for the fire test exposure conditions described in these procedures.

4.3 These test methods provide a measurement of the transmission of heat to the electrical system components within the barrier system.

4.4 These test methods provide qualification of a fire-resistive barrier system as one element of an electrical system designed to maintain continuous operation of critical functions and processes for a specific fire resistance rating.

4.4.1 In addition to the temperature data provided by these test methods, numerous other factors, such as referenced in 1.4 shall be considered in specifying such a system.

#### 5. Control of Fire Test

##### 5.1 *Fire Test Exposure Conditions:*

5.1.1 *Time-Temperature Curve*—Maintain the fire environment within the furnace in accordance with the standard time-temperature curve shown in Test Method E119 or the rapid temperature rise curve shown in Test Method E1529.

##### 5.2 *Furnace Temperatures:*

5.2.1 The temperature fixed by the curve shall be the average temperature obtained from readings of thermocouples distributed within the test furnace. Disperse the thermocouples as symmetrically as possible within the furnace to measure the temperature near all exterior surfaces of the specimen. Do not place the thermocouples at locations where temperature readings would be effected by drafts within the furnace.

5.2.2 Measure and report the temperatures at intervals not exceeding 1 min.

##### 5.3 *Furnace Thermocouples:*

###### 5.3.1 *Test Method E119*—:

5.3.1.1 Enclose the thermocouples in sealed protection tubes of such materials and dimensions that the time constant of the protected thermocouple assembly lies within the range from 300 to 400 s<sup>3</sup>. The exposed length of the pyrometer tube and thermocouple in the furnace chamber shall be not less than 12 in. (305 mm).

5.3.2 *Test Methods E1529*—: ~~Measure the temperature of the gases adjacent to and impinging on the test specimens using factory manufactured 0.25-in. (6-mm) outside diameter (OD), Inconel<sup>4</sup>-sheathed, Type K, chromel-alumel<sup>4</sup> thermocouples. The time constant, in air, of the thermocouple assemblies shall be less than 60 s. Use standard calibration thermocouples with an accuracy of  $\pm 0.75\%$ . A minimum length of 20 diameters (125 mm) of the sheathed junction end of the thermocouple shall be mounted parallel to the surface of the test specimen.~~

5.3.2.1 Measure the temperature of the gases adjacent to and impinging on the test specimens using factory manufactured 0.25-in. (6-mm) outside diameter (OD), Inconel-sheathed, Type K, chromel-alumel thermocouples. The time constant, in air, of the thermocouple assemblies shall be less than 60 s. Use standard calibration thermocouples with an accuracy of  $\pm 0.75\%$ . A minimum length of 20 diameters (125 mm) of the sheathed junction end of the thermocouple shall be mounted parallel to the surface of the test specimen.

<sup>3</sup> A typical thermocouple meeting these time-constant requirements may be fabricated by fusion-welding the twisted ends of No. 18 B&S gage, 0.040 in. (1.02 mm), chromel-alumel wires, mounting the leads in porcelain insulators and inserting the assembly so the thermocouple bead is 0.50 in. (13 mm) from the sealed end of a standard weight, nominal ½ in. iron, steel, or Inconel (a registered trademark of INCO Alloys Inc., 3800 Riverside Dr., P.O. Box 1958, Huntingdon, WV 25720) pipe. The time constant for this and for several other thermocouple assemblies was measured in 1976. The time constant may also be calculated from knowledge of its physical and thermal properties. See Research Report RR:E05-1001, available from ASTM Headquarters.

<sup>4</sup> Buchanan Splice Caps No. 2006S, crimped with a Buchanan C-24 pres-SURE-tool have been found suitable for this purpose (Buchanan Construction Products, Inc., Hackettstown, NJ 07840). The cylindrical splice caps are constructed of thin copper and result in a very secure and robust attachment with the addition of a minimal thermal mass.

5.4 *Furnace Thermocouple Locations*—Position the furnace control thermocouples before the start of the fire exposure test. It shall be permitted to move the thermocouple to avoid touching the specimen as a result of its deflection during the test.

5.4.1 Place the junction of each thermocouple  $12 \pm 1$  in. ( $305 \pm 25$  mm) from the surface of horizontal constructions or  $12 \pm 1$  in. from the surface of specimens mounted in horizontal constructions.

5.4.2 Place the junction of each thermocouple  $6 \pm 1$  in. ( $152 \pm 25$  mm) from the surface of vertical constructions or  $6 \pm 1$  in. from the surface of specimens mounted in vertical constructions.

5.4.3 Use a minimum of three thermocouples.

5.4.3.1 For specimens mounted in horizontal constructions, there shall be no less than five thermocouples per  $100 \text{ ft}^2$  ( $9 \text{ m}^2$ ) of exposed area. Calculate the exposed area to be the sum of the exterior surface area of the fire-resistive barrier system plus the area of the horizontal construction exposed to the furnace fire.

5.4.3.2 For specimens mounted in vertical constructions, there shall be no less than nine thermocouples per  $100 \text{ ft}^2$  ( $9 \text{ m}^2$ ) of exposed area. Calculate the exposed area to be the sum of the exterior surface area of the fire resistive barrier system plus the area of the vertical construction exposed to the furnace fire.

#### 5.5 *Furnace Control:*

##### 5.5.1 *Test Method E119 Time-Temperature Curve:*

5.5.1.1 The control of the furnace control shall be such that the area under the time-temperature curve, obtained by averaging the results from the furnace thermocouple readings, is within 10 % of the corresponding area under the standard time-temperature curve for fire tests of 1 h or less duration, within 7.5 % for those over 1 h and not more than 2 h, and within 5 % for tests exceeding 2 h in duration.

##### 5.5.2 *Test Method E1529 Time-Temperature Curve—Curve:*

5.5.2.1 The control of the furnace shall be such that the area under the time-temperature curve of the average of the gas temperature measurements is within 10 % of the corresponding curve developed in the furnace calibration for tests of 30 min or less duration, within 7.5 % of those over 30 min and not more than 1 h, and within 5 % for tests exceeding 1 h.

5.5.3 If the indicated rating for the protection system is 60 min or more, it shall be increased or decreased by the following correction to compensate for significant variation of the measured furnace temperature from the standard time-temperature curve. The correction is to be expressed by the following formula:

$$C = 2I \frac{A - A_s}{3(A_s + L)} \quad (1)$$

where:

$C$  = correction in the same units as  $I$ ,

$I$  = indicated fire resistance period,

$A$  = area under the curve of the average furnace temperature for the first three fourths of the indicated period,

$A_s$  = area under the standard time-temperature curve for the first three fourths of the indicated period, and

$L$  = lag correction in the same units as  $A$  and  $A_s$ ,  $54^\circ\text{F}\cdot\text{h}$  or  $30^\circ\text{C}\cdot\text{h}$  ( $3240^\circ\text{F}\cdot\text{min}$  or  $1800^\circ\text{C}\cdot\text{min}$ ).  $L$  is only applicable to thermocouples described in 5.3.1 and becomes zero for thermocouples described in 5.3.2.

5.6 *Furnace Calibration*—Test Method E1529 contains a calibration procedure, that is described in the following sections. Test Method E119 does not contain a calibration procedure.

5.6.1 Expose the test specimen to heat flux and temperature conditions representative of total continuous engulfment in the luminous flame regime of a large free-burning fluid-hydrocarbon-fueled pool fire. Use calibration assemblies to demonstrate that the required heat flux and temperature levels are generated in the fire test facility.

5.6.2 Measure the total heat flux using a circular foil heat flux gage (often called a Gardon gage after the developer).

5.6.3 The test setup will provide an average total cold wall heat flux on all exposed surfaces of the test specimen of  $50\,000 \pm 2500 \text{ Btu/ft}^2\cdot\text{h}$  ( $158 \pm 8 \text{ kW/m}^2$ ). The total cold wall heat flux can be controlled by varying the flow of fuel and air. Attain the cold heat flux of  $50\,000 \text{ Btu/ft}^2\cdot\text{h}$  within the first 5 min of the test exposure; maintain this heat flux for the duration of the test.

5.6.4 The temperature of the environment that generates the heat flux of  $50\,000 \text{ Btu/ft}^2\cdot\text{h}$  shall be at least  $1500^\circ\text{F}$  ( $815^\circ\text{C}$ ) after the first 3 min of the test and shall be between  $1850^\circ\text{F}$  ( $1010^\circ\text{C}$ ) and  $2150^\circ\text{F}$  ( $1180^\circ\text{C}$ ) at all times after the first 5 min of the test.

5.6 *Furnace Pressure*—The furnace pressure control described in the sections that follow pertain to tests performed using either of the two time-temperature curves.

5.6.1 Measure the pressure differential between the laboratory ambient air and the interior of the fire test furnace with a minimum of two pressure probes.

5.6.2 Measure the pressure differential between the laboratory ambient air and the interior of the fire test furnace with a minimum of two pressure probes. The pressure measuring probe tips shall be either of the “T” type as shown in Fig. 1 or of the “tube” type as shown in Fig. 2, and shall be manufactured from stainless steel or other suitable material.

5.7.1.1 The pressure measuring probe tips shall be either of the “T” type as shown in Fig. 1, or of the “tube” type as shown in Fig. 2, and shall be manufactured from stainless steel or other suitable material.

##### 5.6.3 *Horizontal Test Assembly—Assembly:*

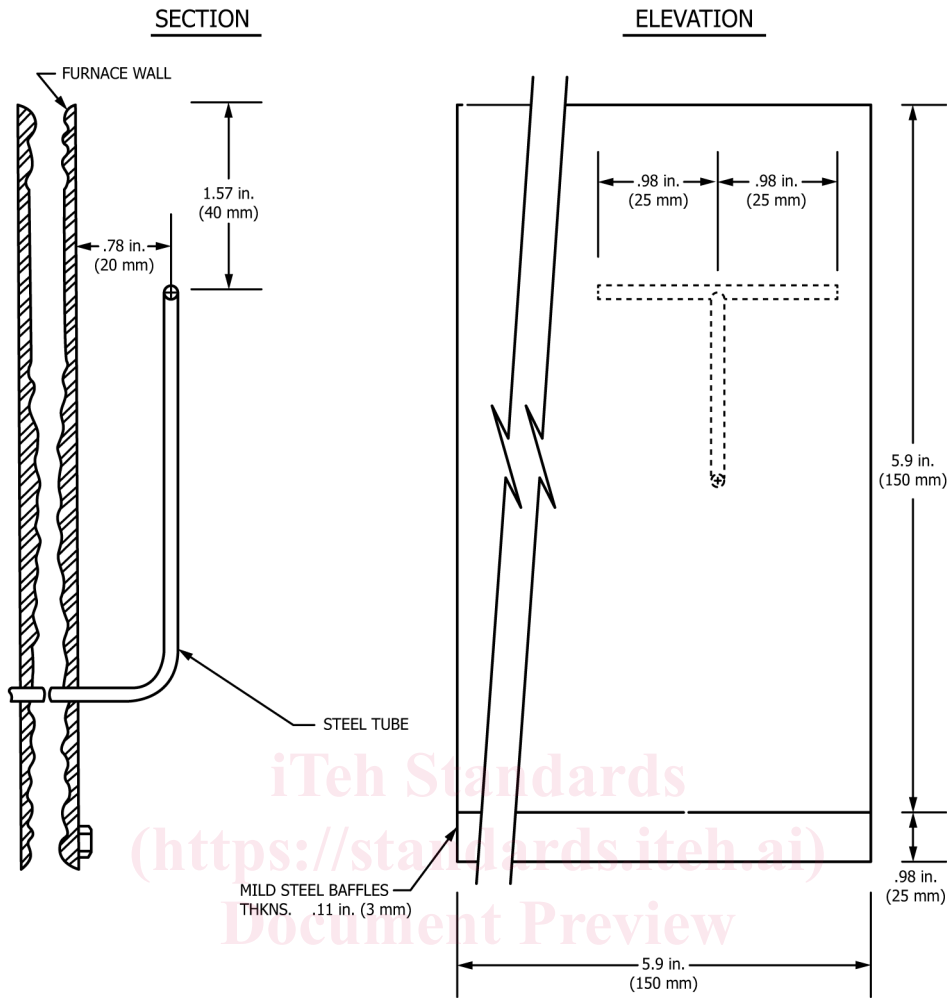

FIG. 1 Furnace Pressure Probe 1

<https://standards.iteh.ai/catalog/standards/sist/abdff1f4-06b8-4d27-9341-4b775e2d4adf/astm-e1725-14e1>

5.6.3.1 Maintain the differential pressure at neutral at a point not less than 12 in. (305 mm) below the exposed surface of the test assembly. No specimen shall be positioned within the heated area of the furnace such that the entire exposed vertical dimension lies below the neutral pressure plane.

5.6.3.2 Locate the pressure measuring probe tips within 6 in. of the vertical centerline of the test specimen. Separate the probes by a minimum of one third of the longest inside dimension of the test furnace. Alternatively, separate the two probes by a minimum of 12 in. (305 mm) vertical distance within the furnace, and the location of the neutral plane calculated as a function of their vertical separation and their pressure difference.

5.6.4 *Vertical Test Assembly—Assembly:*

5.6.4.1 Position specimens within the heated area of the furnace such that at least one half of the vertical dimension lies above the neutral pressure plane.

5.6.4.2 Separate at least two probes by a vertical distance within the furnace equal to one half the furnace height or 12 in. (305 mm), whichever is greatest, and calculate the location of the neutral plane as a function of their vertical separation and their pressure difference.

5.6.5 Measure the pressure by means of a manometer or pressure transducer. The manometer or transducer shall be capable of reading 0.01 in. water (2.5 Pa), with a measurement precision of 0.005 in. water (1.25 Pa).

6. Specimen Construction

6.1 Construct the horizontal or vertical test assembly of materials that offer adequate support for the test specimen during the fire exposure. The designs and installation of the fire-resistive barrier systems and electrical system components shall be representative of actual end use.

6.2 *Electrical System Components*—Test components at their full size and linear dimensions for which evaluation is desired. If the full-size component’s linear dimensions are greater than those specified under each component type in this section, utilize the

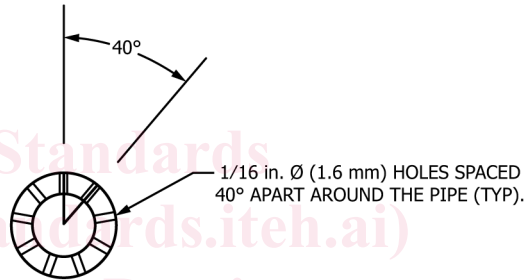
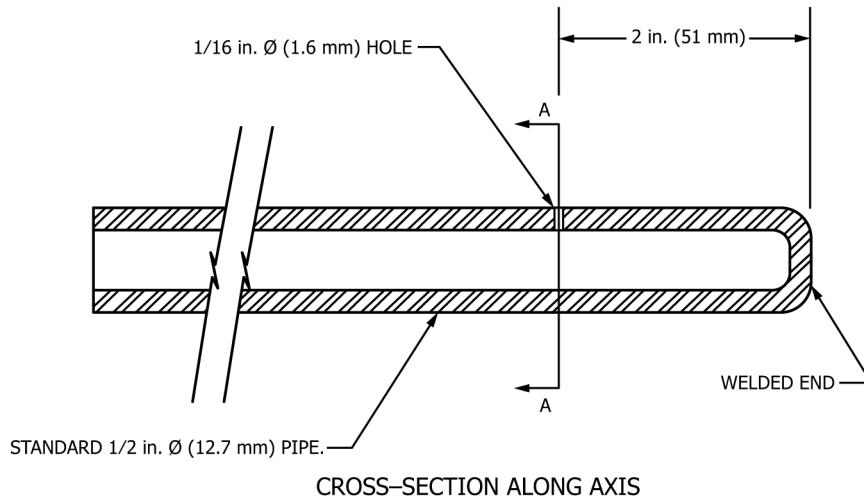

SECTION A-A

FIG. 2 Furnace Pressure Probe 2

ASTM E1725-14e1

<https://standards.iteh.ai/catalog/standards/sist/abdff1f4-06b8-4d27-9341-4b775e2d4adf/astm-e1725-14e1>

dimensions shown, unless data is required for a unique design. Cable trays, conduits, and other raceways are tested without conductors, unless the test is for a unique design. Suggested arrangements are shown in Figs. 3 and 4.

6.2.1 *Cable Trays, Raceways, and Open-Run Cables—Horizontal Assemblies—Cables:*

6.2.1.1 *Horizontal Assemblies:*

6.2.1.2 The exposed vertical depth of the test specimen shall not be less than 36 in. (914 mm).

6.2.1.3 The exposed horizontal length between the inside surfaces of the vertical sections shall not be less than 60 in. (1524 mm).

6.2.2 *Cable Trays, Raceways, and Open-Run Cables—Vertical-Vertical Assemblies:*

6.2.2.1 The exposed vertical height of the test specimen shall not be less than 60 in. (1524 mm).

6.2.2.2 The exposed horizontal depth between the vertical test assembly and the closest surface of the vertical specimen shall not be less than 36 in. (914 mm).

6.2.3 *Airdrop:*

6.2.3.1 To evaluate an airdrop in the vertical configuration only, the exposed vertical length of the test specimen shall not be less than 24 in. (610 mm) (see Fig. 5).

6.2.3.2 To evaluate an airdrop in the horizontal configuration only, the exposed horizontal length shall not be less than 24 in. (610 mm).

6.2.3.3 To evaluate an airdrop for both vertical and horizontal with a bend, the exposed vertical length shall not be less than 24 in. (610 mm) and the exposed horizontal length shall not be less than 24 in. (see Fig. 6).

6.2.4 *Cabinets (Junction and Pull Boxes)—Boxes:* Test these items at their full dimensions for which evaluation is desired.

6.2.4.1 Test these items at their full dimensions for which evaluation is desired.

6.3 Provide assembly with through-penetration fire stops and internal specimen seals. Construct these using materials and techniques capable of withstanding the fire exposure test. Internal seals in cable trays and raceways shall be required in order to eliminate convective cooling of the test specimen.

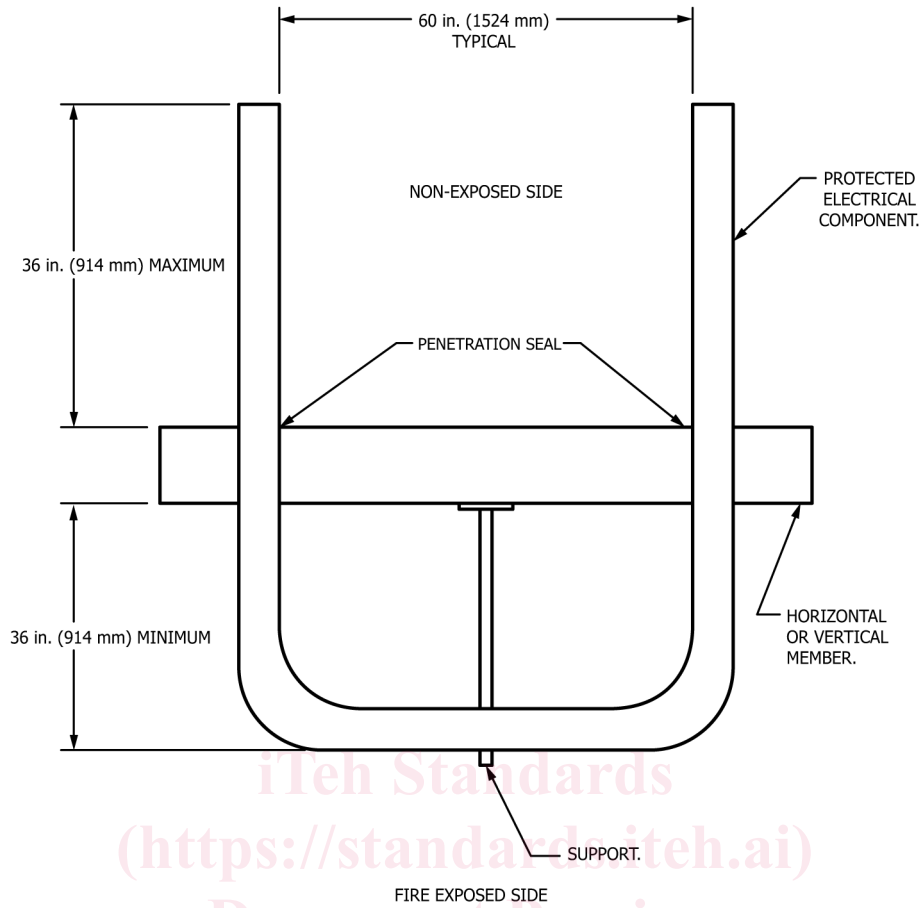

**FIG. 3 Standard Electrical Component Assembly**

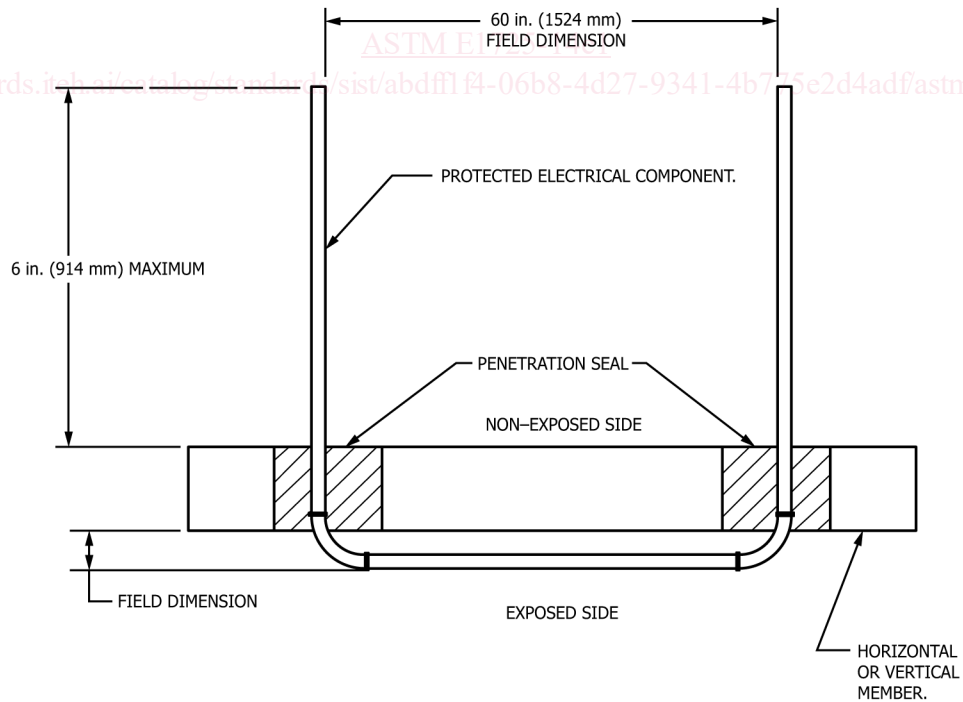

**FIG. 4 Unique Electrical Component Assembly**