



Designation: D6926 – 16

Standard Practice for Preparation of Asphalt Mixture Specimens Using Marshall Apparatus¹

This standard is issued under the fixed designation D6926; the number immediately following the designation indicates the year of original adoption or, in the case of revision, the year of last revision. A number in parentheses indicates the year of last reapproval. A superscript epsilon (ϵ) indicates an editorial change since the last revision or reapproval.

1. Scope

1.1 This practice covers preparation and compaction of 4 in. (101.6 mm) diameter by nominal 2.5 in. (63.5 mm) high cylindrical asphalt paving mixture specimens. This practice is intended for use with laboratory and plant-produced asphalt mixtures with aggregate up to 1 in. (25.4 mm) maximum size and for recompaction of asphalt paving mixture samples.

1.2 There are three types of Marshall compaction apparatus in use. The following types of hammer arrangements are included in this practice:

1.2.1 Manually held hammer handle is attached to a flat compaction foot through a spring-loaded swivel and is hand operated (original standard developed by the United States Army Corps of Engineers).

1.2.2 Hammer handle restrained laterally (fixed) but not vertically, attached to a flat compaction foot through a spring-loaded swivel and is either mechanically or hand operated. There may or may not be a constant surcharge on top of the hammer handle. Mechanical hammers are available that operate at (1) nominal 55 blows per minute or (2) equal to or greater than 75 blows per minute.

1.2.3 Hammer handle restrained laterally (fixed) with constant surcharge on top of hammer, is attached to a slanted compaction foot on a rotating mold base, and is mechanically operated. This method must be used as a referee method.

1.3 Although the mass and height of mass drop for each apparatus are the same, density achieved in compacted specimens with the same number of blows will be different. It is up to the owner or specifier to establish the specific required number of blows to be used for compaction of the specimen in relation to the field.

1.4 *Units*—The values stated in inch-pound units are to be regarded as standard. The values given in parentheses are mathematical conversions to SI units that are provided for information only and are not considered standard.

¹ This practice is under the jurisdiction of ASTM Committee D04 on Road and Paving Materials and is the direct responsibility of Subcommittee D04.20 on Mechanical Tests of Asphalt Mixtures.

Current edition approved Dec. 15, 2016. Published January 2017. Originally approved in 2004. Last previous edition approved in 2010 as D6926 – 10. DOI: 10.1520/D6926-16.

1.5 The text of this standard references notes and footnotes which provide explanatory material. These notes and footnotes (excluding those in tables and figures) shall not be considered as requirements of the standard.

2. Referenced Documents

2.1 *ASTM Standards*:²

D8 Terminology Relating to Materials for Roads and Pavements

D3666 Specification for Minimum Requirements for Agencies Testing and Inspecting Road and Paving Materials

D4402 Test Method for Viscosity Determination of Asphalt at Elevated Temperatures Using a Rotational Viscometer

D6927 Test Method for Marshall Stability and Flow of Asphalt Mixtures

E1 Specification for ASTM Liquid-in-Glass Thermometers

E11 Specification for Woven Wire Test Sieve Cloth and Test Sieves

E77 Test Method for Inspection and Verification of Thermometers

E2251 Specification for Liquid-in-Glass ASTM Thermometers with Low-Hazard Precision Liquids

3. Terminology

3.1 *Definitions*:

3.1.1 For definitions of terms used in this practice, refer to Terminology D8.

3.2 *Definitions of Terms Specific to This Standard*:

3.2.1 *lab mix lab compacted (LMLC) asphalt mixture, n*—asphalt mix samples that are prepared in the laboratory by weighing and blending each constituent then compacting the blended mixture after two hours of curing in the compaction temperature or curing time specified by the owner, using a laboratory compaction apparatus.

3.2.1.1 *Discussion*—LMLC typically occurs during the asphalt mixture design phase.

² For referenced ASTM standards, visit the ASTM website, www.astm.org, or contact ASTM Customer Service at service@astm.org. For *Annual Book of ASTM Standards* volume information, refer to the standard's Document Summary page on the ASTM website.

3.2.2 *plant mix laboratory compacted (PMLC) asphalt mixture, n*—asphalt mix samples that are manufactured in a production plant, sampled prior to compaction, then immediately compacted using a laboratory compaction apparatus.

3.2.2.1 *Discussion*—PMLC specimens are often used for quality control testing. This designation is limited to specimens that have not been permitted to cool substantially, but PMLC samples may be placed in a laboratory oven to equilibrate the mix to the compaction temperature before molding.

3.2.3 *reheated plant mix lab compacted (RPMLC) asphalt mixture, n*—asphalt mix samples that are manufactured in a production plant, sampled prior to compaction, allowed to cool to room temperature, then reheated in a laboratory oven and compacted using a laboratory compaction apparatus.

3.2.3.1 *Discussion*—RPMLCs are often used for quality acceptance and verification testing. The reheating is as brief as possible to obtain uniform temperature while avoiding artificial aging of the specimens. Asphalt mix conditioning, reheat temperature, and reheat time should be defined in the applicable specification.

4. Significance and Use

4.1 Compacted asphalt mixture specimens molded by this procedure are used for various physical tests such as stability, flow, indirect tensile strength, fatigue, creep, and modulus. Density and void analysis are also conducted on specimens for mixture design and evaluation of field compaction.

NOTE 1—Uncompacted mixtures are used for determination of theoretical maximum specific gravity.

NOTE 2—The quality of the results produced by this practice are dependent on the competence of the personnel performing the procedure and the capability, calibration, and maintenance of the equipment used. Agencies that meet the criteria of Specification D3666 are generally considered capable of competent and objective testing, sampling, inspection, etc. Users of this practice are cautioned that compliance with Specification D3666 alone does not completely ensure reliable results. Reliable results depend on many factors; following the suggestions of Specification D3666 or some similar acceptable guideline provides a means of evaluating and controlling some of those factors.

5. Apparatus

5.1 *Specimen Mold Assembly*—Mold cylinders, base plates, and extension collars shall conform to the details shown in Fig. 1 (Compaction Mold).

5.2 *Specimen Extractor*—The specimen extractor shall have a steel disk that will enter the mold without binding and not be less than 3.95 in. (100.3 mm) in diameter and 0.5 in. (12.7 mm) thick. The steel disk is used for extracting compacted specimens from molds with the use of the mold collar. Any suitable extraction device such as a hydraulic jack apparatus or a lever arm device may be used, provided the specimens are not deformed during the extraction process.

5.3 Compaction Hammers:

5.3.1 *Compaction Hammers with a Manually Held (Type 1) or Fixed (Type 2) Handle*, either mechanically or hand operated as generally shown in Figs. 2 and 3, shall have a flat, circular compaction foot with spring-loaded swivel and a 10 ± 0.02 lb (4.545 ± 0.009 kg) sliding mass with a free fall of 18 ± 0.06 in. (457.2 ± 1.5 mm) (see Fig. 2 for hammer tolerances).

A typical manual compaction hammer is shown in Fig. 2. A typical mechanical hammer is shown in Fig. 3.

NOTE 3—Manual compaction hammers should be equipped with a finger safety guard.

5.3.2 *Compaction Hammers with a Fixed Hammer Handle*, surcharge on top of handle, constantly rotating base, and mechanically operated (Type 3), shall have a slanted, circular tamping face and a 10 ± 0.02 lb (4.536 ± 0.009 kg) sliding weight with a free fall of 18 ± 0.06 in. (457.2 ± 1.5 mm). See Fig. 4 (Hammer Bevel Detail) for hammer and tamping face bevel angle and tolerances, respectively. A rotating mechanism is incorporated in the base. The base rotation rate and hammer blow rate shall be 18 to 30 rpm and 64 ± 4 blows per minute, respectively.

NOTE 4—Multiple hammer operation may affect the density of the samples.

5.4 *Compaction Pedestal*—The compaction pedestal shall consist of a 7.5 in. by 8.0 in. (191.0 mm by 203.2 mm) wooden post approximately 18 in. (457.2 mm) long, capped with a steel plate approximately 12 by 12 in. (304.8 by 304.8 mm) and 1 in. (25.4 mm) thick. The wooden post shall be oak, yellow pine, or other wood having an average dry density of 42 to 48 lb/ft³ (674.2 to 770.5 kg/m³). The wooden post shall be secured by bolts through four angle brackets to a solid concrete slab. The steel cap shall be firmly fastened to the post. The pedestal assembly shall be installed so that the post is plumb and the cap is level.

5.5 *Specimen Mold Holder*—With single-hammer compactors, the holder shall be mounted on the compaction pedestal so as to center the compaction mold over the center of the post. The holders shall hold the compaction mold, collar, and base plate securely in position during compaction of the specimen.

5.6 *Ovens, Heating Pots or Hot Plates*—Circulating air ovens or thermostatically controlled heating pots and hot plates shall be provided for heating aggregates, asphalt material, specimen molds, compaction hammers, and other equipment to within 5 °F (3 °C) of the required mixing and compaction temperatures. Suitable shields, baffle plates, or sand baths shall be used on the surfaces of the hot plates to minimize localized overheating.

5.7 *Mixing Apparatus*—Mechanical mixing is recommended, but also can be mixed manually. Any type of mechanical mixer may be used provided the mix can be maintained at the required temperature and mixing will produce a well-coated, homogeneous mixture of the required amount in the allowable time, and further provided that essentially all of the batch can be recovered. A metal pan or bowl of sufficient capacity for hand mixing may also be used.

5.8 Miscellaneous Equipment:

5.8.1 *Containers for Heating Aggregates*, flat-bottom metal pans, or other suitable containers.

5.8.2 *Covered Containers for Heating Asphalt Binder*, either gill-type tins, beakers, pouring pots, or saucepans may be used.

5.8.3 *Mixing Tools*, shall consist of a steel trowel (mason's pointing trowel with point rounded), spoon or spatula, for spading and hand mixing.

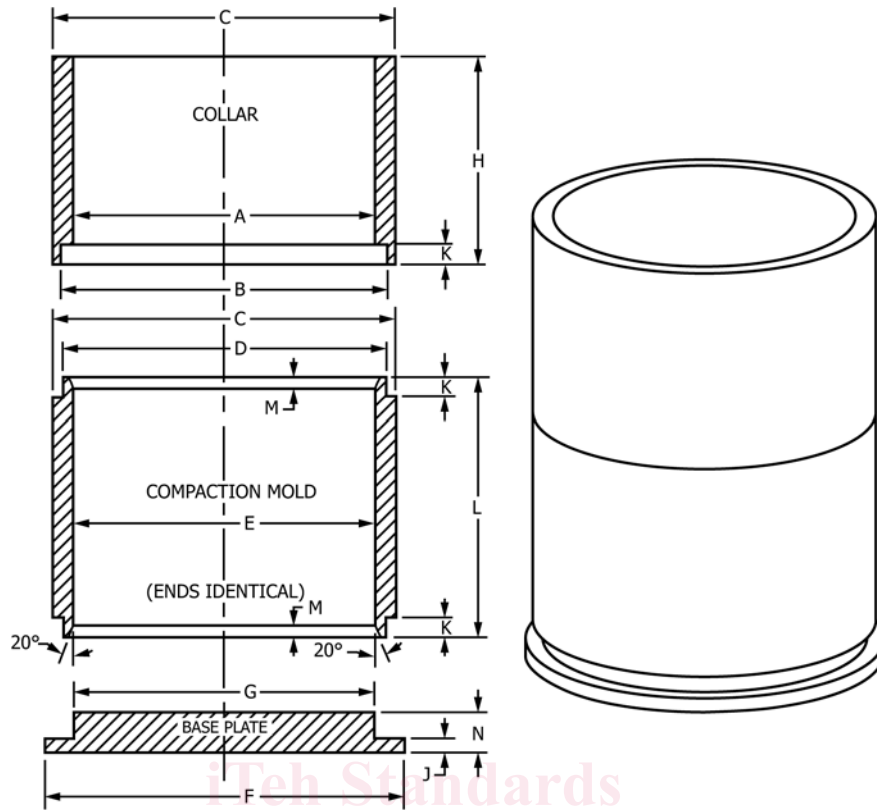

| | in. | (mm) |
|---|----------------|------------------|
| A | 4.100 to 4.150 | (104.1 to 105.4) |
| B | 4.295 to 4.339 | (109.1 to 110.2) |
| C | 4.490 to 4.560 | (114.0 to 115.8) |
| D | 4.211 to 4.320 | (107.0 to 109.7) |
| E | 3.990 to 4.005 | (101.3 to 101.7) |
| F | 4.720 to 4.780 | (119.9 to 121.4) |
| G | 3.980 to 3.990 | (101.1 to 101.3) |
| H | 2.730 to 2.770 | (69.3 to 70.4) |
| J | 0.120 to 0.285 | (3.0 to 7.2) |
| K | 0.235 to 0.295 | (6.0 to 7.5) |
| L | 3.420 to 3.460 | (86.9 to 87.9) |
| M | 0.120 to 0.190 | (3.0 to 4.8) |
| N | 0.485 to 0.585 | (12.3 to 14.9) |

FIG. 1 Compaction Mold

5.8.4 *Thermometer*—the thermometer shall be one of the following:

5.8.4.1 A liquid-in-glass thermometer of suitable range with subdivisions and maximum scale error of 1.0 °F (0.5 °C) which conforms to the requirements of Specification E1. Calibrate the thermometer in accordance with one of the methods in Test Method E77.

5.8.4.2 A liquid-in-glass partial immersion thermometer of suitable range with subdivisions and maximum scale error of 1.0 °F (0.5 °C) which conforms to the requirements of Specification E2251. Calibrate the thermometer in accordance with one of the methods in Test Method E77.

5.8.4.3 Electronic thermometers may be used, for example thermocouples, thermistors, or PRTs, with a readability of 1.0 °F (0.5 °C) that has been calibrated as a system (probe and meter).

5.8.5 *Sieves*—The sieve cloth and standard sieves, given in Specification E11, shall be mounted on substantial frames constructed in a manner that will prevent loss of material during sieving.

NOTE 5—It is recommended that sieves mounted in frames larger than standard 8-in. (203.2-mm) diameter be used for testing coarse aggregates to reduce the possibility of overloading the sieves.

5.8.6 *Balance*, readable to at least 0.1 g for batching mixtures.

5.8.7 *Gloves*, for handling hot equipment.

5.8.8 *Markers*, for identifying specimens.

5.8.9 *Scoop*, flat bottom, for batching aggregates.

5.8.10 *Spoon*, large, for placing the mixture in the specimen molds.