



Designation: **D4971 – 08 D4971 – 16**

Standard Test Method for Determining In Situ Modulus of Deformation of Rock Using Diametrically Loaded 76-mm (3-in.) Borehole Jack¹

This standard is issued under the fixed designation D4971; the number immediately following the designation indicates the year of original adoption or, in the case of revision, the year of last revision. A number in parentheses indicates the year of last reapproval. A superscript epsilon (ϵ) indicates an editorial change since the last revision or reapproval.

1. Scope*

1.1 This test method covers the estimation of in situ modulus of a rock mass at various depths and orientations. Information on time-dependent deformation may also be obtained.

1.2 This test method covers testing in an N size drill hole and is more relevant to a borehole jack device designed for “hard rock” than for soft rock.

1.3 All observed and calculated values shall conform to the guidelines for significant digits and rounding established in Practice **D6026**.

1.3.1 The method used to specify how data are collected, calculated, or recorded in this standard is not directly related to the accuracy to which the data can be applied in design or other uses, or both. How one applies the results obtained using this standard is beyond its scope.

1.4 The values stated in SI units are to be regarded as the standard. The values given in parentheses are mathematical conversions to inch-pound units that are provided for information only and are not considered standard.

1.5 *This standard does not purport to address all of the safety concerns, if any, associated with its use. It is the responsibility of the user of this standard to establish appropriate safety and health practices and determine the applicability of regulatory limitations prior to use.*

2. Referenced Documents

2.1 *ASTM Standards:*²

D653 Terminology Relating to Soil, Rock, and Contained Fluids

D3740 Practice for Minimum Requirements for Agencies Engaged in Testing and/or Inspection of Soil and Rock as Used in Engineering Design and Construction

D6026 Practice for Using Significant Digits in Geotechnical Data

D6032 Test Method for Determining Rock Quality Designation (RQD) of Rock Core

3. Terminology

3.1 See Terminology **D653** for general definitions.

3.1 *Definitions:*

3.1.1 For definitions of common technical terms in this standard, refer to Terminology **D653**.

3.2 *Definitions of Terms Specific to This Standard:*

3.2.1 *deformation—deformation, n*—change in shape or size, (see Terminology **D653**). In this test method deformation is the change in the diameter of the borehole.

3.2.2 *modulus of deformation—deformation, n*—ratio of stress to strain for a material under given loading conditions; numerically equal to the slope of the tangent or the secant of the stress-strain curve. ~~The use of the term modulus of elasticity is recommended for materials that deform in accordance with Hooke’s law, and the term modulus of deformation is recommended for materials that deform otherwise, (see Terminology **D653**).~~ In this test method, the modulus of deformation is calculated from the applied fluid pressure, the relative change in hole diameter, a function of Poisson’s ratio, and a constant.

¹ This test method is under the jurisdiction of ASTM Committee **D18** on Soil and Rock and is the direct responsibility of Subcommittee **D18.12** on Rock Mechanics. Current edition approved July 1, 2008; Dec. 1, 2016. Published July 2008; January 2017. Originally approved in 1989. Last previous edition approved in 2006 as **D4971 – 02 D4971 – 08**. (2006). DOI: 10.1520/D4971-08.10.1520/D4971-16.

² For referenced ASTM standards, visit the ASTM website, www.astm.org, or contact ASTM Customer Service at service@astm.org. For *Annual Book of ASTM Standards* volume information, refer to the standard’s Document Summary page on the ASTM website.

*A Summary of Changes section appears at the end of this standard

3.2.2.1 Discussion—

The use of the term modulus of elasticity is recommended for materials that deform in accordance with Hooke’s law, and the term modulus of deformation is recommended for materials that deform otherwise, (see Terminology D653). In this test method, the modulus of deformation is calculated from the applied fluid pressure, the relative change in hole diameter, a function of Poisson’s ratio, and a constant.

3.2.3 jack efficiency—*efficiency, n*—ratio of the jack plate pressure to the applied hydraulic pressure.

3.2.4 hard rock borehole jack, *n*—this refers to a specific borehole jack by the manufacture that has platens designed for harder rocks, goes to higher pressures than a soft rock borehole jack and whose displacement range is not exceeded at the maximum allowable pressure for the borehole jack.

4. Summary of Test Method

4.1 The drill logs for a drill hole hole to be tested are examined. Specific depths and orientations in the drill hole are selected based upon the objectives of the test program.

4.2 The 76 mm (3.0 in.) borehole jack in the fully retracted position is positioned at each location selected in the drill hole for the test program. The 76 mm (3 in.) jacks, (see Fig. 1 and Fig. 2), induce unidirectional pressure to the walls of a borehole by means of two opposed curved steel platens each covering a 90° sector, over a length of 20.3 cm (8 in.); 20 cm (8 in.) and pressure

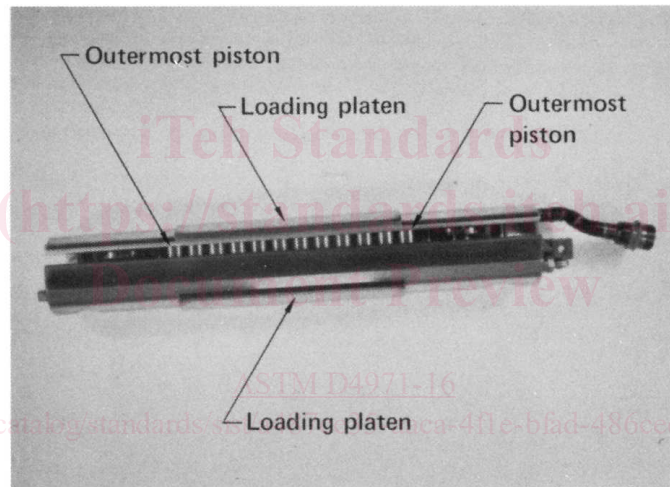

a) Assembled

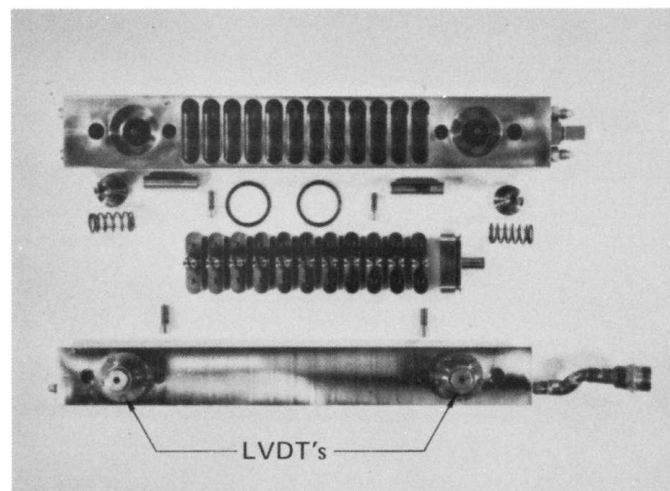

b) Disassembled

FIG. 1 The 76-mm (3-in.) Borehole Jack: Assemble (a) and Disassembled (b)

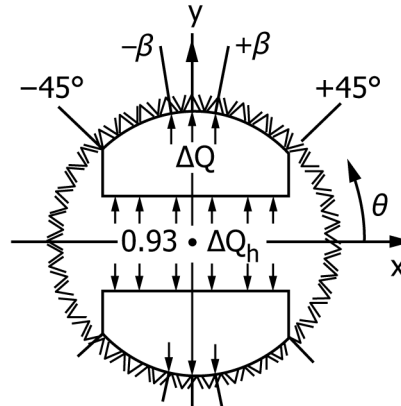

FIG. 2 Schematic of Diametrical Loading of the Borehole JackWall by the Borehole Jack Platens

versus deformation data is collected. Testing is usually done from the deepest test zone in the drill hole and then tested at subsequent shallower test intervals to minimize risks to the borehole jack.

4.3 Raw data from a test consist of hydraulic-line pressure, Q_h , versus readout from linear variable differential transformers (LVDT's) measuring platen movement. Knowing the displacement calibration of the LVDT's, the raw data can be transformed to a test record of hydraulic pressure versus hole diameter, D . For each increment of pressure, ΔQ_h , and hole deformation, ΔD , theoretical data analysis (1),³ assuming rigid jack plates and full 90° contact, give the theoretical rock mass modulus, E ($E_{\text{theoretical}}$) as a function $E = f(\Delta Q_h \cdot \Delta D \cdot T^*)$, where T^* is a coefficient dependent upon Poisson's ratio. If E is measured on a linear segment of the loading curve, common terminology is modulus of deformation. If E is measured on an unloading linear segment, it is referred to as the recovery modulus.

5. Significance and Use

5.1 Results of this test method are used to predict displacements in rock mass caused by loads from a structure or from underground construction. construction. It is one of several tests that should be performed.

5.2 Because the jack can apply directed loads, this test method can be performed to provide an estimate of anisotropy.

5.3 In theory, the analysis of test data is straight forward; the modulus estimate requires a record of applied hydraulic pressure versus borehole diameter change, and a knowledge of the rock's Poisson's ratio. In practice, the above procedure, using the original theoretical formula, frequently has resulted in computing a material modulus that was demonstrably too low.

5.4 For analyzing the test data it is assumed that the rock mass is linearly elastic, isotropic, and homogeneous. Within these assumptions, this test method can provide useful data for rock masses for which equivalent continuous properties ~~can not~~ cannot be found or estimated.

NOTE 1—Notwithstanding the statements on precision and bias contained in this test method; the precision of this test method is dependent on the competence of the personnel performing it, and the suitability of the equipment and facilities used. Agencies that meet the criteria of Practice D3740 are generally considered capable of competent and objective testing. Users of this test method are cautioned that compliance with Practice D3740 does not in itself assure reliable testing. Reliable testing depends on many factors; Practice D3740 provides a means of evaluating some of those factors.

6. Interferences

6.1 It is assumed that the tensile and compressive moduli of the rock are equal and there is no tensile cracking induced in the rock mass because of jack loading. If tensile cracks are created at 90° to the loading direction, it has been shown (1) that the calculated modulus values can decrease by up to 29 %. Therefore, tensile cracking would result in a decrease in the slope of the loading curve and test data in the region of decreased slope should not be used.

6.2 The volume of rock mass involved in the 76 mm (3.0 in.) diameter jack test has been estimated (2) to be about 0.15 m³ (5 ft³). This volume may not include enough discontinuities to be representative of the rock mass on a larger scale.

6.3 Two aspects of jack behavior, discussed in 6.3.1 and 6.3.2, require careful consideration in the analysis of test data and can be compensated for by the procedure outlined in this test method and detailed by Heuze and Amadei (3).

6.3.1 The platen/rock contact may not cover 90° of the borehole circumference, as assumed, because of radius mismatch between the jack platens and the interior wall of the drill hole (4, 5).

³ The boldface numbers in parentheses refer to a list of references at the end of the standard.

6.3.2 In rock with modulus of deformation greater than about 7 GPa (10^6 psi), there is a longitudinal concave outward bending of the jack platens that requires correction. This correction is necessary because the bending gives higher displacements at the ends than at the center of the loading platens and LVDT the displacement gauges are located near the ends of the platens.

6.4 Any effects on the data from the in situ stress field around the borehole wall may need to be considered.

7. Apparatus

7.1 *Borehole Jack*—The borehole jack (Fig. 1) for which equations and corrections are presented in Section 12 is the so-called “hard rock” jack, that is currently manufactured under patent—a patent. A hydraulic hose and electrical cable extending from the borehole jack up the borehole to the surface and is connected to a readout unit or units for reading displacement and to hydraulic pressure system that is used to apply and measure the hydraulic pressure applied to the jack. The manufacturer’s specifications are: range of travel is ± 310 mm (0.5 in.) from closed at 70 mm (2.75 in.) to fully open at 8380 mm (3.25 in.), maximum pressure on borehole wall is 64 MPa (9300 psi), and deformation resolution is 0.025 mm (0.001 in.). The maximum jack pressure is achieved with a hydraulic system pressure of 69 MPa (10 000 psi). Deformation is measured by an LVDT at each end of the loading platens. These are referred to as the near and far LVDT respectively.

7.2 *Pressure Gauge*—A hydraulic gauge or electronic transducer may be used to measure the hydraulic system pressure: pressure to the platens. The gauge or transducer shall have an accuracy of at least 280 kPa (40 psi), including errors introduced by the readout equipment, and a resolution of at least 140 kPa (20 psi) and a range of at least 69 MPa (10 000 psi).

7.3 *Displacement Recorder*—An electronic readout box is used to record the displacement measured by each LVDT associated with the platens. The readout boxes used shall have an accuracy of at least 0.025 mm (0.001 in.) and able to read a range of travel of 10 mm (0.5 in.) from closed at 70 mm (2.75 in.) to full open at 80 mm (3.25 in.).

NOTE 2—A more sophisticated data acquisition system may be used than what is discussed in 7.2 and 7.3. The data acquisition equipment mentioned is sufficient and is usually more robust in the field; especially in more hostile and remote field conditions than it high be for a more sophisticated system.

7.4 *Casing Alignment System*—The borehole jack is attached to 73 mm (2.875 in.) BX drill casing and placed into position in the borehole. To determine the orientation of the jack, an orientation mark is transferred to successive sections of casing as they are added. To avoid introducing a systematic and progressive error into orientation, an alignment device shall be used to transfer the mark from one casing section to another. In vertical boreholes, a plumb line may be sufficient. In inclined or horizontal boreholes, a marking guide such as the one shown on Fig. 3 has been found satisfactory (6).

8. Sampling, Test Specimens, and Test Units

8.1 *Number and Orientation of Boreholes*—The number, spacing, and orientation of boreholes depend on the geometry of the project and the geology of the site.

8.2 Rock Sampling:

8.2.1 Each type of rock should be tested. In addition, areas of low modulus of deformation, such as fracture or alteration zones within a rock mass, are of particular interest and should be tested.

8.2.2 Tests should be conducted at different orientations to sample the anisotropy of the rock mass, for example, parallel and perpendicular to the long axes of the columns in a basalt flow. Boreholes should generally be orthogonal to each other and either parallel or perpendicular to the structure of the rock formation. At least ten tests in each rock material are recommended.

8.3 *Boreholes Reamed*—It is recommended that a reaming shell with a nominal outside diameter of 76 mm (3 in.) be used. It is further recommended that a bit fabricated to reaming shell gauge 76 mm (3 in.) also be used. This will minimize the radius mismatch between the borehole and the jack. Accurate measurement of the diameter of the borehole is important.

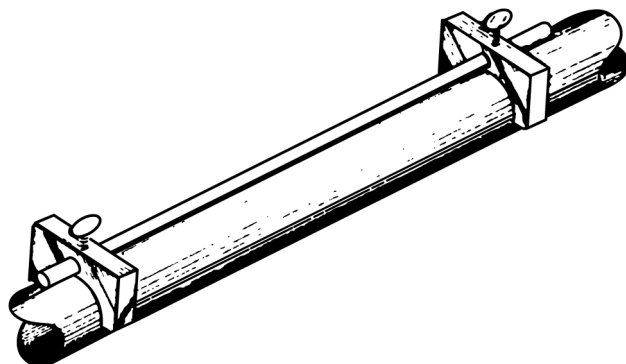

FIG. 3 Marking Guide on Section of Casing

8.4 *Boreholes Cored*—The boreholes shall be drilled using diamond core techniques; continuous core should be obtained. Oriented cores are desirable but not mandatory.

8.5 *Core Logged*—The recovered core should be completely logged, with emphasis on fractures and other mechanical inhomogeneities and water pressure. Rock quality designation (RQD) should be calculated for each 1.5 m (5 ft) of hole cored or core run, in accordance with Test Method [D6032](#).

8.6 *Test Location*—Within each borehole, locations for each test should be selected based on the core logs. In some cases observation of the borehole with a borescope or borehole camera (film or television) may be useful.

9. Personnel and Equipment Requirements

9.1 *Personnel*—All personnel involved in performing the test, including technicians and test supervisors, should be under the guidance of someone thoroughly familiar with the use of the jack. Sometimes the personnel may be required to be formally pre-qualified under a quality assurance (QA) procedures established as part of the overall testing program.

9.2 *Equipment Performance Verification*—The compliance of all equipment and apparatus with performance specifications of this procedure shall be verified. Performance verification is generally done by calibrating the equipment and measurement systems according to established procedures.

10. Calibration

10.1 The borehole jack shall be calibrated before and at the completion of the program according to manufacturer's or equivalent directions ([7](#)). In addition, the jack shall be calibrated during the test program if the program consists of many tests or if the deformation readings become suspect. This is particularly likely if the difference in the readings of near and far LVDT's exceeds the manufacturer's recommendation of 0.5 mm (0.02 in.), indicating excessive misalignment of the platens.

10.2 Calibration of the boreholes jack must be documented. Personnel calibrating the equipment must be qualified in advance.

11. Procedure

11.1 Test each distinctive rock material in a borehole.

11.2 It is recommended that the first test be conducted at the deepest location, and the following tests be at successively shallower depths to prevent possible borehole damage in a given test from interfering with subsequent testing.

11.3 *Testing Discontinuities*—Locate tests in both intact zones and fractured zones to evaluate the effects of discontinuities. If the two LVDT's give significantly different displacement (≥ 0.5 mm or 0.02 in.), discard the data and relocate the jack.

11.4 *Boreholes*—Boreholes shall be free from dirt and drill cuttings. Wash the borehole with clean water if necessary.

11.5 *Initial Seating Pressure*—When the jack is at the test location and in the desired orientation, raise the hydraulic pressure to 350 kPa (50 psi) to seat the platens against the borehole wall. Use this pressure as the “zero” pressure throughout the remainder of the test.

11.6 *Pressure Level*—Test the rock to a pressure in excess of that required for full platen contact, but not exceeding the pressure or displacement capacity of the jack. Failure of the rock may be recognized by an increase in the rate of deformation without corresponding increase in the rate of pressure.

11.7 *Pressure Cycles*—In at least 25 % of the tests in each rock material, conduct multiple-pressure cycling to progressively higher loads to evaluate permanent deformation and the effects of cycling on modulus. The peak pressure shall be approximately 30, 60, and 100 % of the maximum. During each cycle, vary the pressure in at least five equal increments and five decrements. At the end of each cycle, return the pressure to the initial seating pressure.

11.8 *Test at Various Orientations*—If tests are desired in different orientations, it is preferable to move the jack at least 30.5 cm (12 in.) below or above the previous test location so as to provide an undisturbed site for testing. It is suggested that successive orientations be perpendicular to each other. ~~It is recommended that the first test be conducted at the deepest location, and the following tests be at successively shallower depths to prevent possible borehole damage in a given test from interfering with subsequent testing.~~

11.9 *Indications of Time-Dependent Effects*—Determine time dependent deformation characteristics during the test by maintaining the maximum test pressure for 15 min and recording deformation at 5 min intervals. When the pressure is reduced to the initial seating pressure, take deformation readings again at 5 min intervals for 15 min. If at least three such determinations are made in a given rock material, and the deformation indicated by either LVDT changing by more than 5 % of the total accumulated deformation up to that stress level over the 15 min intervals in any of the tests, assume that the material exhibits time-dependent behavior at that stress level, and, follow by further investigation.

11.10 *Data Recording Requirements*—Record the data shown on Test Data Sheet Form 1, (see [Fig. 4](#)) as minimum for the test, (although not necessarily in this format).

TEST DATA SHEET - FORM 1

Project _____	Test No. _____
Date _____	Depth _____
Borehole _____	Orientation _____
Orientation: Bearing _____	Rock Type _____
Inclination _____	Initial Borehole diameter _____
Tested by _____	Readout Magnification Factor _____
<u>Serial Nos. of Calibrated Devices</u> (Jack, pressure gage, etc...)	<u>Date of Last Calibration</u>
_____	_____
_____	_____
_____	_____

Time	Pressure Reading	Near LVDT	Far LVDT
_____	_____	_____	_____
_____	_____	_____	_____
_____	_____	_____	_____
_____	_____	_____	_____
_____	_____	_____	_____
_____	_____	_____	_____
_____	_____	_____	_____
_____	_____	_____	_____
_____	_____	_____	_____

Remarks:

Test Supervisor _____	Date _____
Quality Assurance _____	Date _____
Project Engineer _____	Date _____

FIG. 4 Example of Borehole Jack Test Data Sheet—Form 1

12. Calculation

12.1 *Estimates:* <http://standards.iteh.ai/catalog/standards/sist/a487ce35-aaca-4f1e-bfad-486ccc0b414b/astm-d4971-16>

12.1.1 Obtain a rough estimate of the theoretical in situ mass modulus, $E_{\text{theoretical}}$ by reducing core modulus values from laboratory tests by a factor of 2.5 (2).

12.1.2 *Estimate of Poisson’s Ratio*—Use measured laboratory test values or use $\nu = 0.25$ if no other estimate is available. From the above information, estimate the minimum hydraulic pressure, $Q_{h \text{ min}}$, required for full platen/rock contact (8).⁴ The $Q_{h \text{ min}}/\alpha$ values for $\nu = 0.25$ are shown in Table 1 as a function of true rock modulus for oversize and undersize holes. For more accuracy, the equations in Table 1 may be used. However, $Q_{h \text{ min}}$ is not very sensitive to ν and from a practical standpoint, $\nu = 0.25$ can be used. (As an alternative to these first steps, it may be assumed that there is full jack to borehole contact if the loading curve is linear.

12.2 *Equations and Corrections:*

12.2.1 Measure the radius of the hole at the test location to determine the initial radius mismatch between the jack and the hole (undersize or oversize hole). This is commonly done by an LVDT at 350 kPa (50 psi), “zero” pressure. The radius mismatch, α is defined by $2\alpha = \text{hole diameter} - 76 \text{ mm}$ (3 in.).

12.2.2 In the full contact portion of the record, calculate the apparent modulus, E_{calc} , from:

$$E_{\text{calc}} = (0.86 \times JE \times \Delta Q_h T^*) / (\Delta D / D) \tag{1}$$

where:

- JE = jack efficiency, ratio
- D = hole diameter,
- ΔD = change in hole diameter,
- ΔQ_h = increment of hydraulic-line pressure, and

⁴ It has been suggested (8) that the procedure set forth above to meet the criterion of full-platen seating may result in rejections of too many data with consequent degradation of the quality of the corpus of data. Reports on the experience of users of this test method are needed to evaluate the merits of both the criterion and the procedure itself.