



Designation: D5707 – 16

# Standard Test Method for Measuring Friction and Wear Properties of Lubricating Grease Using a High-Frequency, Linear-Oscillation (SRV) Test Machine<sup>1</sup>

This standard is issued under the fixed designation D5707; the number immediately following the designation indicates the year of original adoption or, in the case of revision, the year of last revision. A number in parentheses indicates the year of last reapproval. A superscript epsilon ( $\epsilon$ ) indicates an editorial change since the last revision or reapproval.

## 1. Scope\*

1.1 This test method covers a procedure for determining a lubricating grease's coefficient of friction and its ability to protect against wear when subjected to high-frequency, linear-oscillation motion using an SRV test machine at a test load of 200 N, frequency of 50 Hz, stroke amplitude of 1.00 mm, duration of 2 h, and temperature within the range of the test machine, specifically, ambient to 280 °C. Other test loads (10 N to 1200 N for SRVI-model, 10 N to 1400 N for SRVII-model, and 10 N to 2000 N for SRVIII-model), frequencies (5 Hz to 500 Hz) and stroke amplitudes (0.1 mm up to 4.0 mm) can be used, if specified. The precision of this test method is based on the stated parameters and test temperatures of 50 °C and 80 °C. Average wear scar dimensions on ball and coefficient of friction are determined and reported.

NOTE 1—Optimol Instruments supplies an upgrade kit to allow SRVI/II-machines to operate with 1600 N, if needed.

1.2 This test method can also be used for determining a fluid lubricant's ability to protect against wear and its coefficient of friction under similar test conditions.

1.3 The values stated in SI units are to be regarded as standard. No other units of measurement are included in this standard.

1.4 *This standard does not purport to address all of the safety concerns, if any, associated with its use. It is the responsibility of the user of this standard to establish appropriate safety and health practices and determine the applicability of regulatory limitations prior to use.*

## 2. Referenced Documents

### 2.1 ASTM Standards:<sup>2</sup>

<sup>1</sup> This test method is under the jurisdiction of ASTM Committee D02 on Petroleum Products, Liquid Fuels, and Lubricants and is the direct responsibility of Subcommittee D02.G0.04 on Functional Tests - Tribology.

Current edition approved Oct. 1, 2016. Published January 2017. Originally approved in 1995. Last previous edition approved in 2011 as D5707 – 11. DOI: 10.1520/D5707-16.

<sup>2</sup> For referenced ASTM standards, visit the ASTM website, www.astm.org, or contact ASTM Customer Service at service@astm.org. For *Annual Book of ASTM Standards* volume information, refer to the standard's Document Summary page on the ASTM website.

[A295/A295M Specification for High-Carbon Anti-Friction Bearing Steel](#)

[D217 Test Methods for Cone Penetration of Lubricating Grease](#)

[D4175 Terminology Relating to Petroleum Products, Liquid Fuels, and Lubricants](#)

[D5706 Test Method for Determining Extreme Pressure Properties of Lubricating Greases Using a High-Frequency, Linear-Oscillation \(SRV\) Test Machine](#)

[D6425 Test Method for Measuring Friction and Wear Properties of Extreme Pressure \(EP\) Lubricating Oils Using SRV Test Machine](#)

[D7755 Practice for Determining the Wear Volume on Standard Test Pieces Used by High-Frequency, Linear-Oscillation \(SRV\) Test Machine](#)

[E45 Test Methods for Determining the Inclusion Content of Steel](#)

[G40 Terminology Relating to Wear and Erosion](#)

### 2.2 Other Standards:<sup>3</sup>

[DIN EN ISO 683-17 Heat-treated Steels, alloy steels and free-cutting steels—Part 17 : Ball and roller bearing steels](#)

[DIN 51834-3 Testing of lubricants—Tribological test in translatory oscillation apparatus—Part 3: Determination of tribological behaviour of materials in cooperation with lubricants](#)

[DIN EN ISO 13565-2:1998 Geometrical Product Specifications \(GPS\)—Surface texture: Profile method; Surfaces having stratified functional properties —Part 2: Height characterization using linear material ratio curve \[Replaces DIN 4776:1990: Measurement of surface roughness; parameters  \$R\_K\$ ,  \$R\_{PK}\$ ,  \$R\_{VK}\$ ,  \$M\_{r1}\$ ,  \$M\_{r2}\$  for the description of the material portion\]](#)

## 3. Terminology

### 3.1 Definitions:

3.1.1 *break-in, n—in tribology*, an initial transition process occurring in newly established wearing contacts, often accompanied by transients in coefficient of friction or wear rate, or

<sup>3</sup> Available from Deutsches Institut für Normung e.V.(DIN), Burggrafenstrasse 6, 10787 Berlin, Germany, <http://www.din.de>.

\*A Summary of Changes section appears at the end of this standard

both, which are uncharacteristic of the given tribological system's long-term behavior. **G40**

3.1.2 *coefficient of friction, n*—in tribology, the dimensionless ratio of the friction force ( $F$ ) between two bodies to the normal force ( $N$ ) pressing these bodies together. **G40**

3.1.3 *Hertzian contact area, n*—the apparent area of contact between two nonconforming solid bodies pressed against each other, as calculated from Hertz's equations of elastic deformation. **G40**

3.1.4 *Hertzian contact pressure, n*—magnitude of the pressure at any specified location in a Hertzian contact area, as calculated from Hertz's equations of elastic deformation. The Hertzian contact pressure can also be calculated and reported as maximum value  $P_{\max}$  in the centre of the contact or as  $P_{\text{average}}$  as average over the total contact area. **G40**

3.1.5 *lubricant, n*—any material interposed between two surfaces that reduces the friction or wear between them. **D4175**

3.1.6 *lubricating grease, n*—a semifluid to solid product of a dispersion of a thickener in a liquid lubricant.

3.1.6.1 *Discussion*—The dispersion of the thickener forms a two-phase system and immobilizes the liquid lubricant by surface tension and other physical forces. Other ingredients are commonly included to impart special properties. **D217**

3.1.7 *Ra (C.L.A.), n*—measuring surface finish, the arithmetic average of the absolute distances of all profile points from the mean line for a given distance.<sup>4</sup>

3.1.7.1 *Discussion*—C.L.A. means center line average, and it is a synonym for Ra.

3.1.8 *Rpk, n*—reduced peak height according to DIN EN ISO 13565-2:1998. Rpk is the mean height of the peak sticking out above the core profile section.

3.1.9 *Rvk, n*—reduced valley height according to DIN EN ISO 13565-2:1998. Rvk is the mean depth of the valley reaching into the material below the core profile section.

3.1.10 *Rz (DIN), n*—in measuring surface finish, the average of all  $R_y$  values (peak to valley heights) in the assessment length.<sup>5</sup>

3.1.11 *thickener, n*—in lubricating grease, a substance composed of finely divided particles dispersed in a liquid lubricant to form the product's structure.

3.1.11.1 *Discussion*—The thickener can be fibers (such as various metallic soaps) or plates or spheres (such as certain non-soap thickeners) which are insoluble or, at most, only very slightly soluble in the liquid lubricant. The general requirements are that the solid particles be extremely small, uniformly dispersed, and capable of forming a relatively stable, gel-like structure with the liquid lubricant. **D217**

3.1.12 *wear, n*—damage to a solid surface, generally involving progressive loss of material, due to the relative motion between that surface and a contacting substance or substances. **G40**

3.1.13 *Wv, n*—Wear volume is the loss of volume to the ball after a test. **D6425**

3.2 *Definitions of Terms Specific to This Standard:*

3.2.1 *seizure, n*—localized fusion of metal between the rubbing surfaces of the test pieces.

3.2.1.1 *Discussion*—Seizure is usually indicated by a sharp increase in coefficient of friction, wear, or unusual noise and vibration. In this test method, increase in coefficient of friction is displayed on the chart recorder as a permanent rise in the coefficient of friction from a steady state value.

3.3 *Abbreviations:*

3.3.1 *SRV, n*—Schwingung, Reibung, Verschleiss, (German); oscillating, friction, wear, (English translation). **D5706**

## 4. Summary of Test Method

4.1 This test method is performed on an SRV test machine using a test ball oscillated under constant load against a test disk.

NOTE 2—The frequency of oscillation, stroke length, test temperature, test load, and test ball and disk material can be varied from those specified in this test method. The test ball yields Hertzian point contact geometry. To obtain line or area contact, test pieces of differing configurations can be substituted for the test ball.

4.2 The wear scar on the test ball and coefficient of friction are measured. If a profilometer is available, a trace of the wear scar on the test disk can also be used to obtain additional wear information in order to calculate the wear volumes of ball and disk by using Practice **D7755** or DIN 51834, part 3.

## 5. Significance and Use

5.1 This test method can be used to determine wear properties and coefficient of friction of lubricating greases at selected temperatures and loads specified for use in applications where high-speed vibrational or start-stop motions are present for extended periods of time under initial high Hertzian point contact pressures. This test method has found application in qualifying lubricating greases used in constant velocity joints of front-wheel-drive automobiles and for lubricating greases used in roller bearings. Users of this test method should determine whether results correlate with field performance or other applications.

## 6. Apparatus

6.1 *SRV Test Machine*,<sup>6</sup> illustrated in Figs. 1-4.

6.2 *Microscope*, equipped with a filar eyepiece graduated in 0.005 mm division or equipped with a micrometer stage readable to 0.005 mm. Magnification should be sufficient to allow for ease of measurement. One to 10 $\times$  magnification has been found acceptable.

<sup>6</sup> The sole source of supply of the apparatus known to the committee at this time is Optimol Instruments Prüftechnik GmbH, Westendstrasse 125, D-80339, Munich, Germany, <http://www.optimol-instruments.de>. If you are aware of alternative suppliers, please provide this information to ASTM International Headquarters. Your comments will receive careful consideration at a meeting of the responsible technical committee,<sup>1</sup> which you may attend.

<sup>4</sup> Amstutz, Hu, "Surface Texture: The Parameters," Bulletin MI-TP-003-0785, Sheffield Measurement Division, Warner and Swasey, 1985, p. 21.

<sup>5</sup> Amstutz, Hu, "Surface Texture: The Parameters," Bulletin MI-TP-003-0785, Sheffield Measurement Division, Warner and Swasey, 1985, pp. 29, 31.



FIG. 1 SRV Test Machine (Model III)

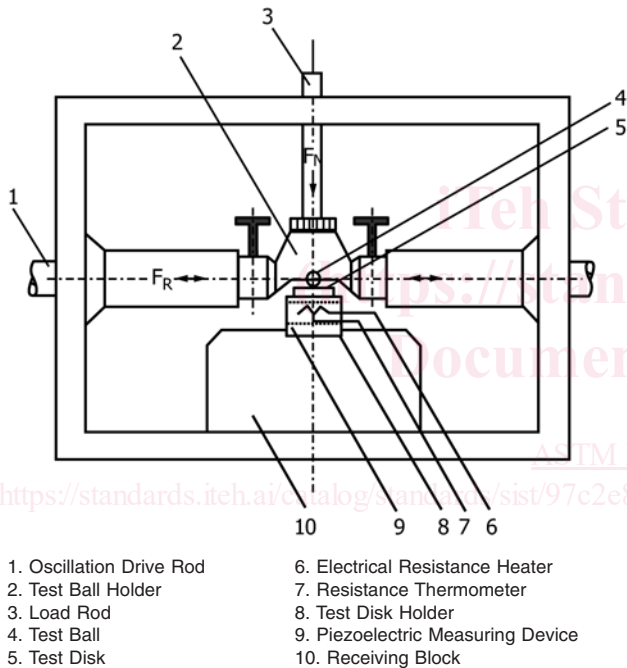

FIG. 2 Test Chamber Elements of SRV III



FIG. 3 SRV Test Machine (Model IV)

## 7. Reagents and Materials

7.1 *Test Balls*<sup>6</sup>, 52100 steel, Rockwell hardness number of  $60 \pm 2$  on Rockwell C scale (HRC),  $0.025 \mu\text{m} \pm 0.005 \mu\text{m}$  *Ra* surface finish, 10 mm diameter.

7.2 *Lower Test Disk*,<sup>6</sup> vacuum arc remelted (VAR) AISI 52100 steel with an inclusion rating using Method D, Type A, as severity level number of 0.5 according to Test Methods E45 and Specification A295/A295M or an inclusion sum value  $K1 \leq 10$  according to DIN EN ISO 683-17 and spheroidized annealed to obtain globular carbide, Rockwell hardness number of  $60 \pm 2$  on Rockwell C scale (HRC), the surfaces of the disk being lapped and free of lapping raw materials. The topography of the disk will be determined by four values, 24 mm diameter by 7.85 mm thick:

$0.5 \mu\text{m} < R_z \text{ (DIN)} < 0.650 \mu\text{m}$   
 $0.035 \mu\text{m} < R_a \text{ (C.L.A.)} < 0.050 \mu\text{m}$   
 $0.020 \mu\text{m} < R_{pk} < 0.035 \mu\text{m}$   
 $0.050 \mu\text{m} < R_{vk} < 0.075 \mu\text{m}$

NOTE 3—The DIN 17230-1980 was replaced by DIN EN ISO 683-17.

7.3 *n-Heptane*, reagent grade. (**Warning**—Flammable. Health hazard.)

7.4 *Isopropanol*, reagent grade. (**Warning**—Flammable. Health hazard.)

7.5 *Toluene*, reagent grade. (**Warning**—Flammable. Health hazard.)

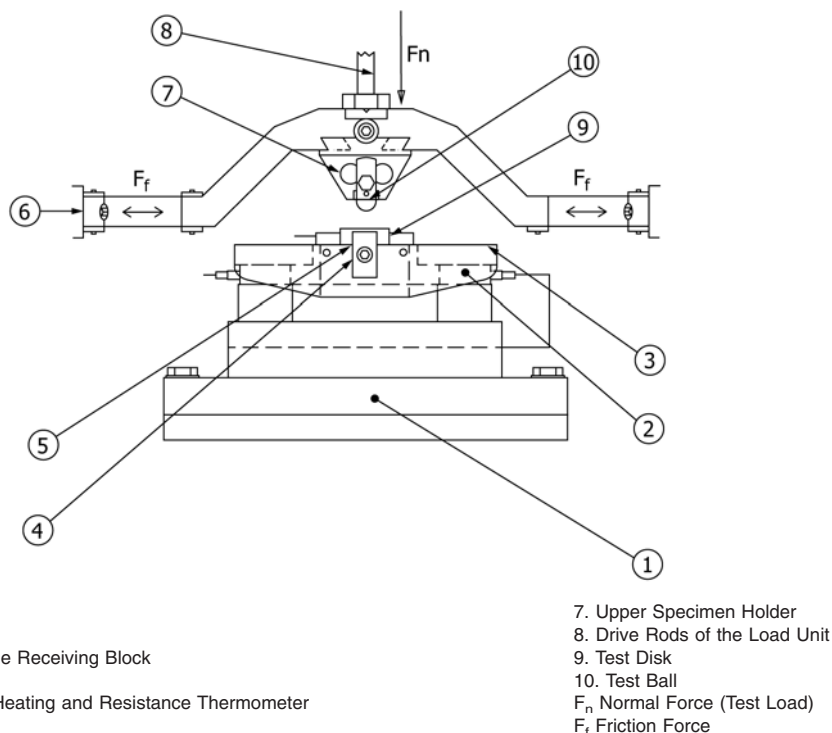

FIG. 4 Test Chamber Elements of SRV Models IV and SRV V

7.6 *Cleaning Solvent*, the test disks have to be cleaned by a liquid solvent (non-chlorinated, non-forming).

NOTE 4—It is recommended to use a mixture of equal volumes of *n*-heptane, isopropanol, and toluene, all as reagent grades. (**Warning**—Flammable. Health hazard.)

## 8. Preparation of Apparatus

### Preparation of SRV I and II Models

8.1 Turn on the test machine and chart recorder and allow to warm up for 15 min prior to running tests.

8.2 Select the friction data to be presented in the crest peak value position on the test apparatus in accordance with the manufacturer's directions.

NOTE 5—In most cases, this is accomplished by positioning the sliding switch on electronic card No. 291.35.20E (front side of electronics behind the front panel) and the sliding switch located on the back panel of the control unit.

8.3 Turn the amplitude knob to ZERO.

8.4 Switch the stroke adjustment to AUTO position.

8.5 Set the frequency to 50 Hz and duration to 2 h, 00 min, 30 s, in accordance with the manufacturer's instructions.

8.6 Set the desired span and calibrate the chart recorder in accordance with the manufacturer's instructions. Select the desired chart speed.

### Preparation of the SRV III, IV, and V Models

8.7 When using SRV III, SRV IV, and SRV V models, clean and install the specimens as specified under 9.1 to 9.7. Turn on

the test machine and the PC and allow to warm up for 15 min prior to running tests.

8.8 Create a set point profile in the SRV control software with the following parameters:

NOTE 6—Depending on the software version, names and availability of the parameters can vary.

#### 8.8.1 Start conditions (thermostatic stabilization):

Temperature: for example, 50 °C ± 1 K or 80 °C ± 1 K or 120 °C ± 1 K  
 Test load: 50 N ± 1 N  
 Start delay: 300 s (is displayed by all versions of the SRV software).

#### 8.8.2 Cut-off criteria for friction, if occurs:

Coefficient of friction, *f* (cut-off value for permanent increase of level):  
 0.3 during  $t > 20$  s  
 Coefficient of friction, *f* (cut-off value for one-off increase of level): 0.35

#### 8.8.3 Test parameters:

Frequency: 50 Hz  
 Stroke: 1.00 mm for procedure  
 Temperature: for example, 50 °C, 80 °C, or 120 °C  
 Pre-load: 50 N for 30 s  
 Test load: running-in under 50 N for 30 s, then steps of 200 N

#### 8.8.4 Sample rates for result-relevant measurement channels:

Coefficient of friction, *f*: ≤32 ms.  
 Stroke: ≤2 s  
 Test load: ≤2 s  
 Frequency: ≤2 s  
 Temperature: ≤2 s  
 After that, apply a load increment of 100 N every 2 min

NOTE 7—For SRV V models, it is recommended to do one sampling per period (that is, 20 ms) for coefficient of friction and stroke.