



Designation: **F3022 – 15 F3022 – 16**

Standard Test Method for Evaluating the Universal Design of Fitness Equipment for Inclusive Use by Persons with Functional Limitations and Impairments¹

This standard is issued under the fixed designation F3022; the number immediately following the designation indicates the year of original adoption or, in the case of revision, the year of last revision. A number in parentheses indicates the year of last reapproval. A superscript epsilon (ϵ) indicates an editorial change since the last revision or reapproval.

INTRODUCTION

The goal of this test method is to provide reliable and repeatable methods for the evaluation of universally designed fitness equipment.

The equipment user must recognize, however, that the standard alone will not necessarily prevent injuries. Like other physical activities, exercise involving fitness equipment involves the risk of injury, particularly if the equipment is used improperly or not properly maintained. In addition, users with physical limitations should seek medical advice and instruction from the fitness facility prior to using this equipment. Certain physical conditions or limitations may preclude some persons from using the equipment properly and without increasing the risk of serious injury.

1. Scope

1.1 This test method² specifies procedures and equipment used for testing and evaluating the accessibility of fitness equipment for compliance to Specification **F3021** design parameters. Where possible and applicable, accepted test methods from other recognized bodies will be used and referenced. In case of a conflict between this document and Specification **F3021**, Specification **F3021** takes precedence.

1.2 This test method is to be used in conjunction with Specification **F3021**.

1.3 This standard is to be used as additional requirements to address the accessibility of the equipment for persons with disabilities.

NOTE 1—Additional test methods applicable to specific pieces of equipment, such as treadmills, bicycles, ellipticals, and strength equipment are currently under development.

1.4 The values stated in SI units are to be regarded as the standard. The values given in parentheses are for information only.

1.5 *This standard does not purport to address all of the safety concerns, if any, associated with its use. It is the responsibility of the user of this standard to establish appropriate safety and health practices and determine the applicability of regulatory limitations prior to use.*

2. Referenced Documents

2.1 *ASTM Standards:*³

E177 Practice for Use of the Terms Precision and Bias in ASTM Test Methods

E691 Practice for Conducting an Interlaboratory Study to Determine the Precision of a Test Method

F2571 Test Methods for Evaluating Design and Performance Characteristics of Fitness Equipment

F3021 Specification for Universal Design of Fitness Equipment for Inclusive Use by Persons with Functional Limitations and Impairments

¹ This test method is under the jurisdiction of ASTM Committee **F08** on Sports Equipment, Playing Surfaces, and Facilities and is the direct responsibility of Subcommittee **F08.30** on Fitness Products.

Current edition approved April 1, 2015/Oct. 1, 2016. Published May 2015/January 2017. Originally approved in 2013. Last previous edition approved in 2014/2015 as **F3022 – 14/F3022 – 15**. DOI: 10.1520/F3022-15.10.1520/F3022-16.

² This work was funded, in part, by the Rehabilitation Engineering Research Center on RecTech through the National Institute on Disability-Disability, Independent Living, and Rehabilitation Research under the US Department of Education grant #H133E070029 and H133E120005 grant #90RE5009-01-00.

³ For referenced ASTM standards, visit the ASTM website, www.astm.org, or contact ASTM Customer Service at service@astm.org. For *Annual Book of ASTM Standards* volume information, refer to the standard's Document Summary page on the ASTM website.

3. Terminology

3.1 *Definitions*—For definitions applicable to this standard see Specification **F3021**.

4. Certification

4.1 ~~These test methods permit self-certification. It is recommended that each manufacturer employ an independent laboratory to evaluate and validate that their designs and test procedures conform and comply with these test methods and Specification **F3021**.~~

~~NOTE 2—The test methods and procedures described in Section 7 should be supported by conducting user testing using subjects across a range of disabilities, impairments, and ages and those without disability on the sample equipment.~~

4. Sample Preparation

4.1 Assemble and adjust the fitness equipment apparatus on a horizontal surface according to the manufacturer's instructions. Verify that assembled units are done so according to the manufacturer's instructions. Unless otherwise stated, the fitness equipment apparatus must pass the following tests without adjustment from this initial condition.

4.2 Any equipment with a removable/movable seat shall be set up with the seat in the non-moved position.

4.3 The individual test methods will describe any variations or modifications that are required to the test sample.

6. Report

~~6.1 *Record of Tests*—Maintain complete test records and test summary reports for all testing, whether performed by the manufacturer or an independent laboratory. The records can be stored on paper, electronically, or on photographs, or a combination thereof. A copy of the test summary must be kept by the laboratory that performed the test for a minimum of five years from the date of the test and by the manufacturer for a minimum of five years past the end of production of the model tested. The summary shall include the signature of the person(s) performing the tests and a management representative of the laboratory performing the test. The test summary shall include the following information:~~

~~6.1.1 Manufacturer's name and location;~~

~~6.1.2 Information provided by the manufacturer to accurately identify the configuration of, and specific unit provided to, the testing agency;~~

~~6.1.3 Dates over which the tests were conducted;~~

~~6.1.4 Name and location of the testing laboratory, if different from the manufacturer, and~~

~~6.1.5 Summary and results of each test performed including method and apparatus used. This shall include what the desired requirement was and whether the test sample met that parameter or failed. If the test requires a specific number of cycles to be met, then the report must include the number of cycles actually conducted. If the apparatus fails to meet a parameter, then that failure must be noted in clear and accurate terms to enable a reader of the report to understand at a later date what transpired.~~

5. Test Methods and Procedures

5.1 *General Requirements:*

5.1.1 *Access and Set Up:*

5.1.1.1 *Access, Egress, and Transfer*—This test is a visual inspection of the sample to ensure that all access paths to the piece of equipment, set in the start position, are not obstructed by the frame or other structural parts of the equipment.

Apparatus and Set Up—The sample shall be set up as described in Section **54**.

Calibration—No calibration required. Visual inspection only.

Procedure—Inspect all access paths to verify that the path is clear of any obstruction by the frame or other structural parts.

Pass/Fail Criteria—The access path shall conform to the clear space requirements of subsection 5.1.1.1 of Specification **F3021**.

Precision and Bias—No information is presented about either the precision or bias of test ~~7.1.1~~**5.1.1.1** for evaluating access since the test result is non-quantitative.

~~NOTE 2—Performance tests to get on/off the equipment from the perspective of a broad range of people with disabilities, including people using wheelchairs or those who have functional limitations, sensory deficits, cognitive impairments, visual, or hearing impairments, or a combination thereof, is suggested. One possible method would be to use testers with disabilities.~~

5.1.1.2 *Maximum Approach Positions*—This test is a visual inspection of the sample to ensure that access paths to the piece of equipment, set in the start position, are available from as many positions as possible (that is, front, rear, left, and right).

Apparatus and Set Up—The sample shall be set up as described in Section **54**.

Calibration—No calibration required. Visual inspection only.

Procedure—Inspect access paths from the front, rear, left, and right of the equipment to verify that the path is clear of any obstruction by the frame or other structural parts from as many points of access as possible.

Pass/Fail Criteria—Equipment must be accessible and shall avoid left/right bias as specified in the requirements of subsection 5.1.1.2 of Specification **F3021**. There is no pass/fail criteria.

Precision and Bias—Equipment must be accessible and shall avoid left/right bias as specified in the requirements of subsection 5.1.1.2 of Specification F3021. There is no pass/fail criteria.

5.1.1.3 *Step-On Height*—This test is a dimensional inspection of the sample to ensure the dimensional compliance of the step-on height.

Apparatus and Set Up—The sample shall be set up as described in Section 54 in the neutral position with 0%–0 % grade/zero incline.

Calibration—Verify that the distance measuring equipment is calibrated and accurate to within 1 mm (0.040 in.).

Procedure—Measure the height from the floor to the top of the highest portion of the step-on surface/frame or top of the transfer surface (see Fig. 1).

Pass/Fail Criteria—The dimensions of the step-on height shall conform to dimensional requirements of subsection 5.1.1.3 of Specification F3021.

Precision and Bias—No information is presented about either the precision or bias of test 7-1-1-35.1.1.3 for measuring step-on height dimensions since the test result is non-quantitative.

5.1.1.4 *Step-Over Height*—This test is a dimensional inspection of the sample to ensure the dimensional compliance of the step-over height.

Apparatus and Set Up—The sample shall be set up as described in Section 54.

Calibration—Verify that the distance measuring equipment is calibrated and accurate to within 1 mm (0.040 in.).

Procedure—Locate the part of the structure that must be stepped over in order to use the equipment. Measure the distance from the floor to the top of the highest step-over point of the frame (see Fig. 2).

Pass/Fail Criteria—The dimensions of the step-over height shall conform to dimensional requirements of subsection 5.1.1.4 of Specification F3021.

Precision and Bias—No information is presented about either the precision or bias of test 7-1-1-45.1.1.4 for measuring step-over height dimensions since the test result is non-quantitative.

5.1.1.5 *Integral Surface/Separate Step Height*—This test is a dimensional inspection of the sample to ensure the dimensional compliance of the step-on/step-over height, with the addition of an integral surface or separate step.

Apparatus and Set Up—The sample shall be set up as described in Section 54 with an integral surface or separate step intact.

Calibration—Verify that the distance measuring equipment is calibrated and accurate to within 1 mm (0.040 in.).

Procedure—Locate the part of the structure that must be stepped on/over in order to use the equipment. Measure the distance from the surface of the integral surface or separate step to the top of the highest step-over point of the frame (see 7-1-1-45.1.1.4).

Pass/Fail Criteria—The dimensions of the integral surface or separate step height shall conform to dimensional requirements of subsection 5.1.1.5 of Specification F3021.

Precision and Bias—No information is presented about either the precision or bias of test 7-1-1-55.1.1.5 for measuring integral surface or separate step height dimensions since the test result is non-quantitative.

5.1.1.6 *Integral Surface/Separate Step Length/Width/Height*—This test is a dimensional inspection of the sample to ensure the dimensional compliance of the integral surface and separate step length, width, and height.

Apparatus and Set Up—The sample shall be set up as described in Section 54 with an integral surface or separate step intact.

Calibration—Verify that the distance measuring equipment is calibrated and accurate to within 1 mm (0.040 in.).

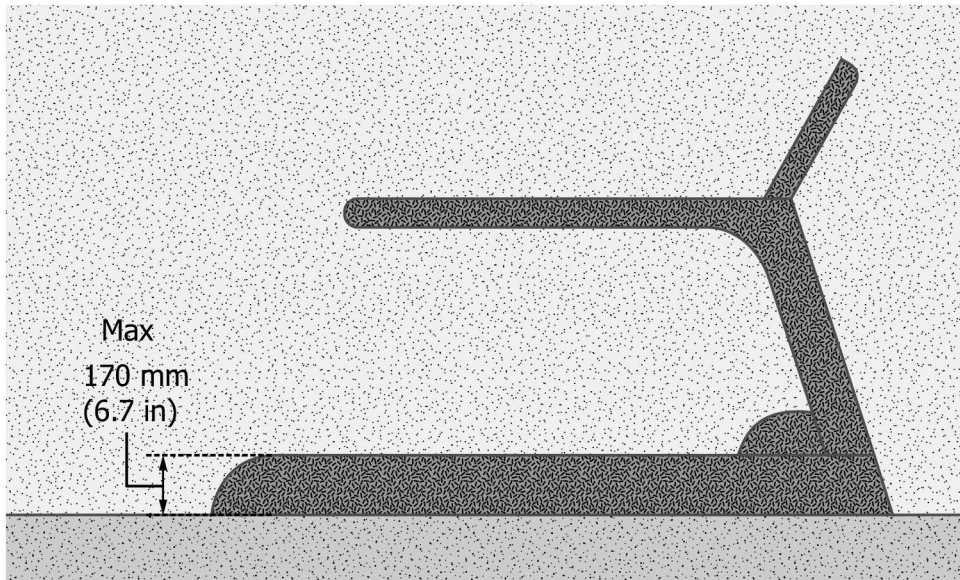

FIG. 1 Maximum Step-on Height Example

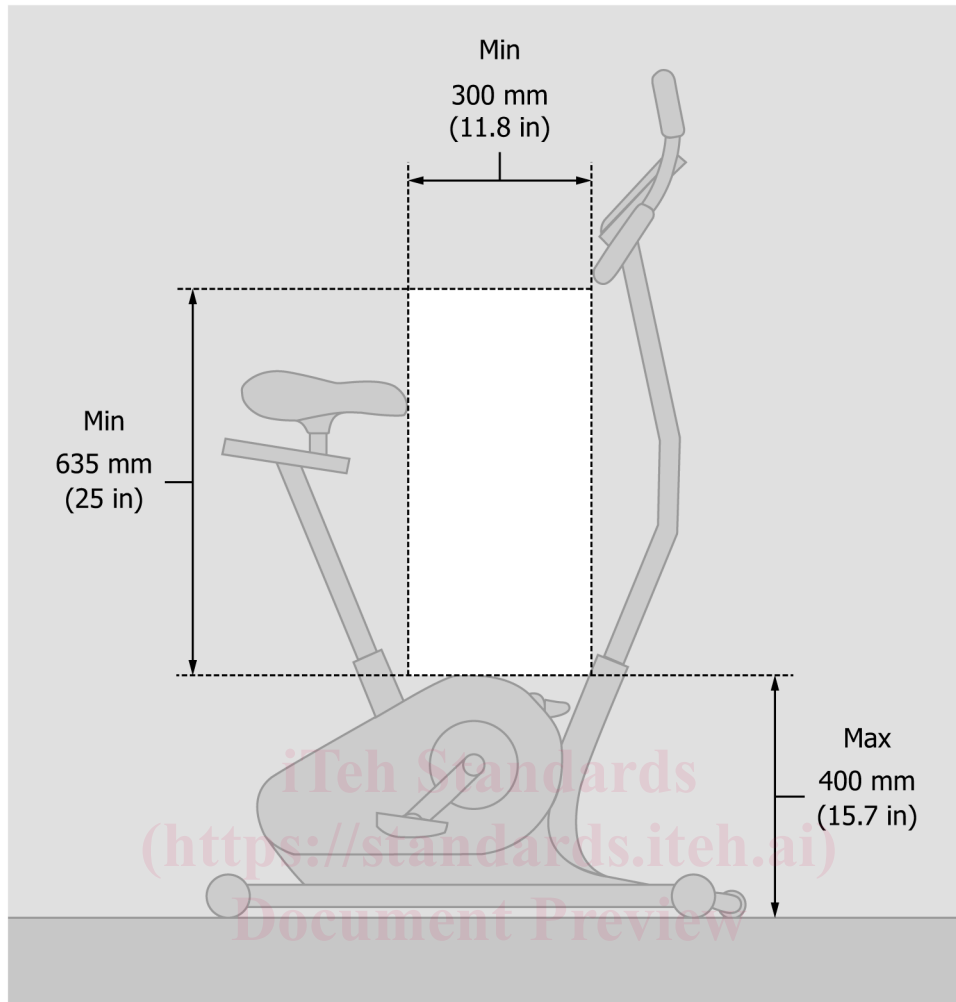

FIG. 2 Maximum Step-over Height Example

<https://standards.iteh.ai/catalog/standards/sist/e3c52535-be66-4987-8382-f923e2e6235a/astm-f3022-16>

Procedure—Measure the height from the floor to the top of the stepping surface of the integral surface or separate step. Measure the length and width from the outer edge of the stepping surface lengthwise and the outer edge of the stepping surface widthwise on the integral surface or separate step.

Pass/Fail Criteria—The dimensions of the integral surface or separate step length/width/height shall conform to dimensional requirements of subsection 5.1.1.6 of Specification F3021.

Precision and Bias—No information is presented about either the precision or bias of test 7.1.1.65.1.1.6 for measuring integral surface and separate step length, width, and height dimensions since the test result is non-quantitative.

5.1.1.7 *Integral Surfaces/Separate Steps—Significant Color Value Contrast*—Perform the color value measurement test in 7.35.3.

5.1.1.8 *Intentional/Unintentional Movement*—This test is a performance and dimensional inspection of the sample to ensure that separate steps do not unintentionally move during use and that they have appropriate mechanisms to facilitate intentional movement.

Apparatus and Set Up—The sample shall be set up as described in Section 54 on carpet for testing the ease of moving the step and on tile or similar flooring for testing for unintentional movement during use.

Calibration—Verify that the force measuring equipment is calibrated and accurate to within 0.5 N (0.1 lbf) over its entire range.

Procedure—Check for skids or wheel lock mechanism. Step on/off the step on tile or similar flooring and visually inspect for unintentional movement during use. Pull the step over carpet flooring and measure the pull force.

Pass/Fail Criteria—The step unintentional/intentional movement shall conform to performance requirements of subsection 5.1.1.8 of Specification F3021.

Precision and Bias—No information is presented about either the precision or bias of test 7.1.1.85.1.1.8 for evaluating and measuring step unintentional/intentional movement since the test result is non-quantitative.

5.1.1.9 *Seated Cardio Back Support*—This test is a visual inspection of the sample to ensure that any seated cardio equipment has an integral back support.

Apparatus and Set Up—The sample shall be set up as described in Section 54.

Calibration—No calibration required. Visual inspection only.

Procedure—Verify that the seated cardio equipment has a back support intact.

Pass/Fail Criteria—The presence of the seated cardio back support shall conform to the requirements of subsection 5.1.1.9 of Specification F3021.

Precision and Bias—No information is presented about either the precision or bias of test 7.1.1.95.1.1.9 for seated cardio back support since the test result is non-quantitative.

5.1.1.10 *Walk Through Structure Clear Area*—This test is a performance inspection of the sample to ensure the dimensional compliance of walk through structure height.

Apparatus and Set Up—The sample shall be set up as described in Section 54.

Calibration—Verify that the distance measuring equipment is calibrated and accurate to within 1 mm (0.040 in.).

Procedure—Step through the walk through area of the equipment. Make sure that there is adequate low structure height to step through without impediment or obstruction. Measure the height from the floor to the highest part of the walk through structure.

Pass/Fail Criteria—The dimensions of the walk through structure area shall conform to dimensional requirements of subsection 5.1.1.95.1.1.10 of Specification F3021.

Precision and Bias—No information is presented about either the precision or bias of test 7.1.1.105.1.1.10 for measuring walk through structure area dimensions since the test result is non-quantitative.

5.1.1.11 *Walk Through Transition Area Box*—This test is a dimensional inspection of the sample to ensure the dimensional compliance of walk through structure area.

Apparatus and Set Up—The sample shall be set up as described in Section 54.

Calibration—Verify that the distance measuring equipment is calibrated and accurate to within 1 mm (0.040 in.).

Procedure—Measure the height and width of the transition area (see Fig. 3).

Pass/Fail Criteria—The dimensions of the transition area box shall conform to dimensional requirements of subsection 5.1.1.105.1.1.11 of Specification F3021.

Precision and Bias—No information is presented about either the precision or bias of test 7.1.1.115.1.1.11 for measuring the transition area box dimension since the test result is non-quantitative.

5.1.1.12 *Recumbent Cardio Seat Forwards/Backwards Range*—This test is a performance and dimensional inspection of the sample to ensure the dimensional compliance of the seat forwards/backwards range.

Apparatus and Set Up—The sample shall be set up as described in Section 54.

Calibration—Verify that the distance measuring equipment is calibrated and accurate to within 1 mm (0.040 in.).

Procedure—Adjust the seat from lowest (forward) to highest (back) position. Set the seat to its lowest position. Measure the horizontal distance of the seat range from a specific point on the seat frame between the lowest (forward) to highest (back) positions (see Fig. 4).

ASTM F3022-16

<https://standards.iteh.ai/catalog/standards/sist/e3c52535-be66-4987-8382-f923e2e6235a/astm-f3022-16>

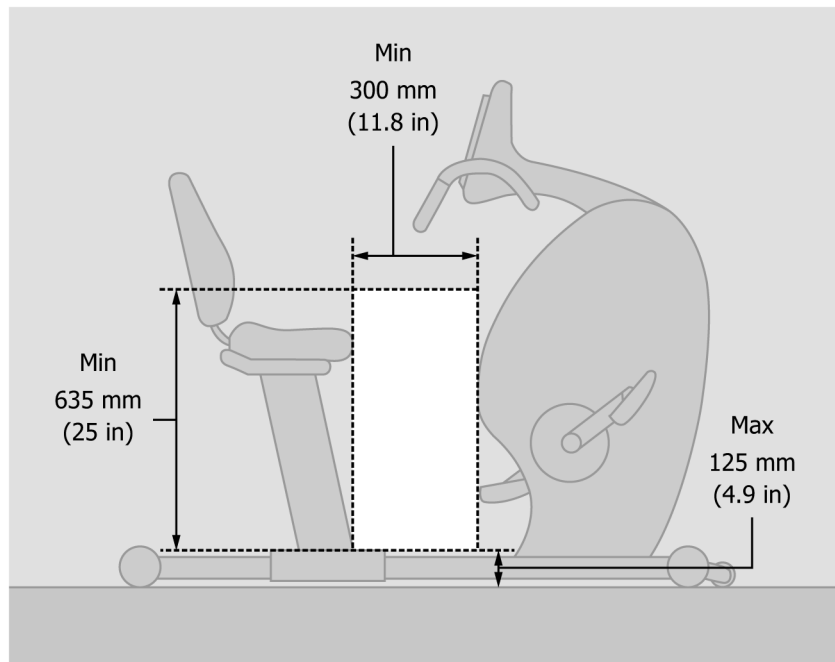

FIG. 3 Minimum Dimensions for Transition Area Box

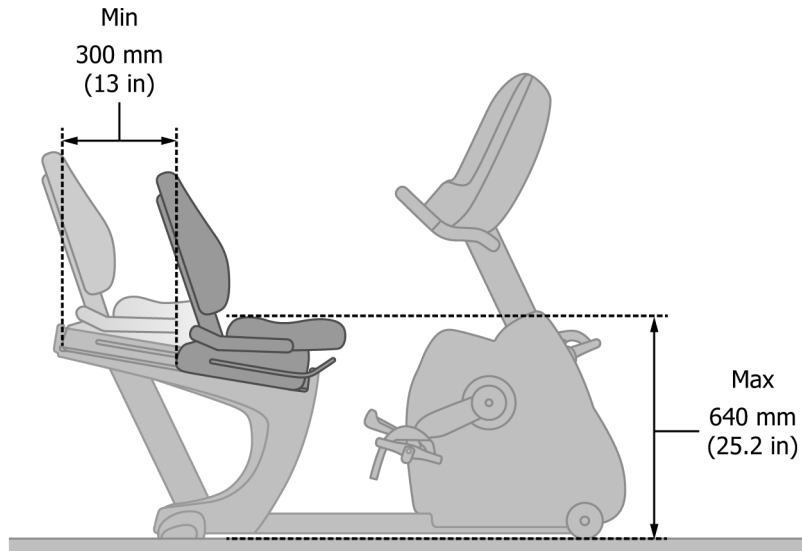

FIG. 4 Recumbent Bicycle Seat Dimensions

Pass/Fail Criteria—The recumbent bicycle seat height forwards/backwards range shall conform to dimensional requirements of subsection 5.1.1.12 of Specification F3021.

Precision and Bias—No information is presented about either the precision or bias of test 7.1.1.125.1.1.12 for measuring recumbent bicycle seat forwards/backwards range since the test result is non-quantitative.

5.1.1.13 *Recumbent Cardio Swivel Seat*—This test is a performance inspection of the sample to ensure the compliance of a swivel seat for cardio equipment which enables both upper limb function/movement.

Apparatus and Set Up—The sample shall be set up as described in Section 54.

Calibration—No calibration required. Performance test only.

Procedure—If cardio equipment enables both upper limb function/movement, verify that the seat swivels to the right and left, in an axis perpendicular to and passing through the center of the primarily horizontal seat pan surface.

Pass/Fail Criteria—The recumbent bicycle swivel seat shall conform to performance requirements of subsection 5.1.1.13 of Specification F3021.

Precision and Bias—No information is presented about either the precision or bias of test 7.1.1.135.1.1.13 for the presence of a swivel seat since the test result is non-quantitative.

(1) *Recumbent Cardio Swivel Seat Lock*—This test is a performance inspection of the sample to ensure the compliance of a swivel seat locking positions.

Apparatus and Set Up—The sample shall be set up as described in Section 54.

Calibration—No calibration required. Performance test only.

Procedure—If cardio equipment has a swivel seat, verify that it locks in the center (primary exercise position), 45° and 90° to the right of center (primary exercise position), and 45° and 90° to the left of center.

Pass/Fail Criteria—The recumbent bicycle swivel seat locking positions shall conform to performance requirements of subsection 5.1.1.13(1) of Specification F3021.

Precision and Bias—No information is presented about either the precision or bias of test 7.1.1.135.1.1.13(1) for the presence of a swivel seat locking positions since the test result is non-quantitative.

5.1.1.14 *Recumbent Cycle Seat Height*—This test is a performance and dimensional inspection of the sample to ensure the dimensional compliance of the seat height.

Apparatus and Set Up—The sample shall be set up as described in Section 54.

Calibration—Verify that the distance measuring equipment is calibrated and accurate to within 1 mm (0.040 in.).

Procedure—Adjust the seat to the lowest (forward) position. Measure the height of the seat from the ground to the top of the sitting surface. If a step is used, then measure the height of the seat from top of the step surface to the top of the sitting surface (see Fig. 4).

Pass/Fail Criteria—The recumbent bicycle seat height shall conform to dimensional requirements of subsection 5.1.1.14 of Specification F3021.

Precision and Bias—No information is presented about either the precision or bias of test 7.1.1.145.1.1.14 for measuring recumbent bicycle seat height dimensions since the test result is non-quantitative.

(1) Any separate or integral step used to meet the saddle height requirement must comply with Test Method F3022, subsections 7.1.1.65.1.1.6 – 7.1.1.85.1.1.8.

5.1.1.15 *Hand/Foot Support Locking Mechanism*—This test is a performance inspection of the sample to ensure that the hand/foot supports lock in place during mounting/dismounting.

Apparatus and Set Up—The sample shall be set up as described in Section 54.

Calibration—No calibration required. Performance test only.

Procedure—Adjust the hand/foot supports for mounting and verify that they are able to be locked in place.

Pass/Fail Criteria—The hand/foot support locking mechanism shall conform to the requirements of subsection 5.1.1.15 of Specification F3021.

Precision and Bias—No information is presented about either the precision or bias of test 7.1.1.15.1.1.15 for evaluating the hand/foot support locking mechanism since the test result is non-quantitative.

5.1.1.16 *Fixed Hand Grips*—This test is a visual inspection of the sample to ensure that fixed hand grips are provided for seated cardio equipment.

Apparatus and Set Up—The sample shall be set up as described in Section 54.

Calibration—No calibration required. Visual test only.

Procedure—If the equipment is seated cardio, verify that there are fixed hand grips available.

Pass/Fail Criteria—The fixed hand grips shall conform to the requirements of subsection 5.1.1.16 of Specification F3021.

Precision and Bias—No information is presented about either the precision or bias of test 7.1.1.16.1.1.16 for evaluating fixed hand grips since the test result is non-quantitative.

5.1.1.17 *Toe Retention*—This test is a visual and dimensional inspection of the sample to ensure that adjustable toe retentions are provided to prevent the foot from slipping off the pedals during exercise.

Apparatus and Set Up—The sample shall be set up as described in Section 54.

Calibration—No calibration required. Visual and performance test only.

Procedure—Verify that there are adjustable toe retentions, for example, straps available on any pedals/foot platforms for use during exercise. Test the toe strap while using the bicycle with a shoe size of a 5 % female and a shoe size of a 95 % male.

Pass/Fail Criteria—The toe retentions shall conform to dimensional requirements of subsection 5.1.1.17 of Specification F3021.

Precision and Bias—No information is presented about either the precision or bias of test 7.1.1.17.1.1.17 for evaluating toe retentions since the test result is non-quantitative.

5.1.1.18 *Foot Support Length/Width*—This test is a dimensional inspection of the sample to ensure the dimensional compliance of the foot support length and width.

Apparatus and Set Up—The sample shall be set up as described in Section 54.

Calibration—Verify that the distance measuring equipment is calibrated and accurate to within 1 mm (0.040 in.).

Procedure—Measure the length of the foot support through the centerline from the front outer guard edge to the rear outer guard edge. Measure the width of the foot support through the centerline from the right outer guard edge to the left outer guard edge.

Pass/Fail Criteria—The foot support length and width shall conform to the dimensional requirements of subsection 5.1.1.18 of Specification F3021.

Precision and Bias—No information is presented about either the precision or bias of test 7.1.1.18.1.1.18 for measuring foot support length and width dimensions since the test result is non-quantitative.

5.1.1.19 *Foot Retention*—This test is a visual and performance inspection of the sample to ensure the presence and dimensional compliance of the foot retention, for example, rear raised guard or strap, height on foot supports.

Apparatus and Set Up—The sample shall be set up as described in Section 54.

Calibration—Verify that the distance measuring equipment is calibrated and accurate to within 1 mm (0.040 in.).

Procedure—Verify that there are foot retentions present around the inside and outside edges of each foot support. Measure the height of the retention of each foot support from the inner top edge to the inner bottom edge. Measure the length of the retention and the foot support; calculate the percentage of foot retention length compared to the foot support length.

Pass/Fail Criteria—The presence and dimensions of the foot retention height shall conform to dimensional requirements of subsection 5.1.1.19 of Specification F3021.

Precision and Bias—No information is presented about either the precision or bias of test 7.1.1.19.1.1.19 for measuring foot retention height dimensions since the test result is non-quantitative.

5.1.1.20 *Heel Retention*—This test is a visual and performance inspection of the sample to ensure the presence and dimensional compliance of the heel retention, for example, rear raised guard or strap, height on foot supports.

Apparatus and Set Up—The sample shall be set up as described in Section 54.

Calibration—Verify that the distance measuring equipment is calibrated and accurate to within 1 mm (0.040 in.).

Procedure—Verify that there is heel retention present on the back edge of each foot support. Measure the height of the heel retention of each foot support from the inner top edge to the inner bottom edge.

Pass/Fail Criteria—The presence and dimensions of the heel retention height shall conform to dimensional requirements of subsection 5.1.1.20 of Specification F3021.

Precision and Bias—No information is presented about either the precision or bias of test 7-1-1-205.1.1.20 for measuring heel retention height dimensions since the test result is non-quantitative.

5.1.1.21 *Highlight Potential Trip Hazards—Significant Color Value Contrast*—Perform the color value measurement test in 7-35.3.

5.1.1.22 *Foot Support/Pedal Heel and Toe Retentions—Significant Color Value Contrast*—Perform the color value measurement test in 7-35.3.

5.1.2 *Seats, Sitting Surfaces, and Back Supports:*

5.1.2.1 *Sitting Surface Width/Depth/Back Support Angle*—This test is a dimensional inspection of the sample to ensure the dimensional compliance of the seat/sitting surface width, depth, and back support angle.

Apparatus and Set Up—The sample shall be set up as described in Section 54.

Calibration—Verify that the distance measuring equipment is calibrated and accurate to within 1 mm (0.040 in.) and the angle measuring equipment is calibrated and accurate to within 0.1°.

Procedure—Measure the width across the top of the sitting support surface from the left outer side edge to the right outer side edge at the widest point in the hip/pelvic area. Measure the depth of the top of the sitting support surface from the front edge of the hip/pelvic area to the back edge through the centerline. If the seat/sitting surface has a back support, measure the seat angle in the middle on top of the hip/pelvic support area from the horizontal reference of the floor (see Fig. 5).

Pass/Fail Criteria—The dimensions of the seat/sitting surface width, depth, and back support angle shall conform to dimensional requirements of subsection 5.1.2.1 of Specification F3021.

Precision and Bias—No information is presented about either the precision or bias of test 7-1-2-15.1.2.1 for measuring sitting surface width, depth, and back support angle dimensions since the test result is non-quantitative.

5.1.2.2 *Fixed Seat Height*—This test is a dimensional inspection of the sample to ensure the dimensional compliance of the seat height.

Apparatus and Set Up—The sample shall be set up as described in Section 54.

Calibration—Verify that the distance measuring equipment is calibrated and accurate to within 1 mm (0.040 in.).

Procedure—Measure the height of the seat from the ground to the top of the sitting surface (see Fig. 6).

Pass/Fail Criteria—The dimensions of the seat height shall conform to dimensional requirements of subsection 5.1.2.2 of Specification F3021.

Precision and Bias—No information is presented about either the precision or bias of test 7-1-2-25.1.2.2 for measuring fixed seat height dimensions since the test result is non-quantitative.

5.1.2.3 *Adjustable Seat Height Range*—This test is a dimensional inspection of the sample to ensure that there is a seat height option within the specified range on adjustable seats.

Apparatus and Set Up—The sample shall be set up as described in Section 54.

Calibration—Verify that the distance measuring equipment is calibrated and accurate to within 1 mm (0.040 in.).

Procedure—Measure the height of the seat from the ground to the top of the sitting surface with the seat in the lowest and highest position. Verify that the seat height can be adjusted within the specified range.

Pass/Fail Criteria—The dimensions of the adjustable seat height range shall conform to dimensional requirements of subsection 5.1.2.3 of Specification F3021.

Precision and Bias—No information is presented about either the precision or bias of test 7-1-2-35.1.2.3 for measuring the adjustable seat height range since the test result is non-quantitative.

5.1.2.4 *Seat Height Adjustability*—This test is a performance inspection of the sample to ensure that the seat height is adjustable.

Apparatus and Set Up—The sample shall be set up as described in Section 54.

Calibration—No calibration required. Performance test only.

Procedure—Verify that the seat height is adjustable. Adjust the seat from lowest to highest position.

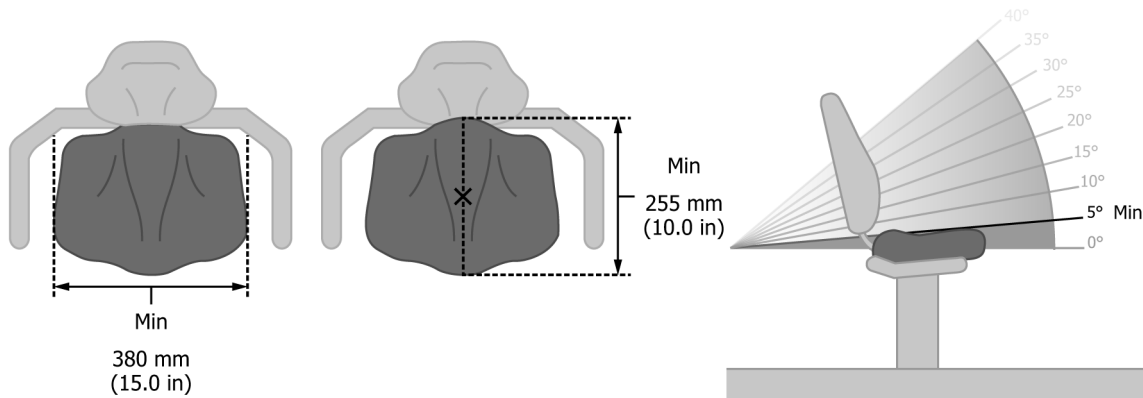

FIG. 5 Minimum Seat Dimensions – Width, Depth, Angle

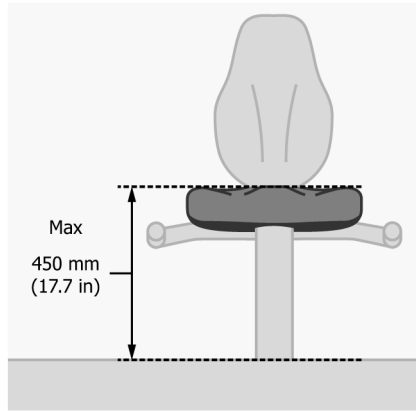

FIG. 6 Maximum Seat Dimensions – Height

Pass/Fail Criteria—The seat height adjustability shall conform to the requirements of subsection 5.1.2.4 of Specification F3021.

Precision and Bias—No information is presented about either the precision or bias of test 7-1-2-45.1.2.4 for measuring the seat height adjustability since the test result is non-quantitative.

5.1.2.5 *Removable/Movable Seat*—This test is a dimensional inspection of the sample to ensure that the clear space and floor area is free of obstacles when a removable/movable seat is removed/moved.

Apparatus and Set Up—The sample shall be set up as described in Section 5.4.

Calibration—Verify that the distance measuring equipment is calibrated and accurate to within 1 mm (0.040 in.).

Procedure—Remove/Move the seat from its active position to its storage position. Measure the length, width, and height of the accessible clear space area. Measure the height of any obstacle(s) that remain in the accessible clear space in the floor area.

Pass/Fail Criteria—The seat shall be capable of being removed/moved into a storage position with an accessible clear space floor area that conforms to the requirements of subsection 5.1.2.5 of Specification F3021.

Precision and Bias—No information is presented about either the precision or bias of test 7-1-2-55.1.2.5 for evaluating and measuring seat removability/movability, clear space, and obstacle height since the test result is non-quantitative.

NOTE 3—Reminder when testing for stability of the equipment, the seat in the removed/moved position would be the most onerous position for testing.

5.1.2.6 *Start Position/Hand Grip(s) Clearance*—This test is a dimensional inspection of the sample to ensure that when removable/movable seats are removed/moved, that there is sufficient distance between the back support and exercise hand grips when a wheelchair is in the exercise position.

Apparatus and Set Up—The sample shall be set up as described in Section 5.4.

Calibration—Verify that the distance measuring equipment is calibrated and accurate to within 1 mm (0.040 in.).

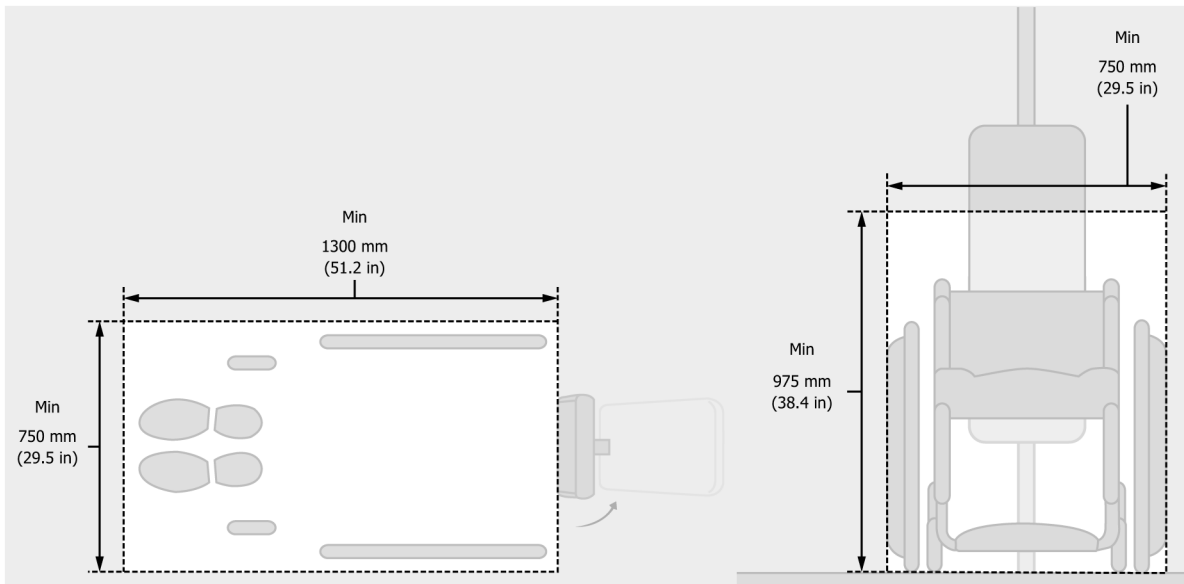

FIG. 7 Removable/Movable Minimum Clear Space Area

Procedure—Remove/Move the seat from its active position to its storage position. Measure the horizontal distance between the closest start position of the hand grips designed for wheelchair use and the back support (see Fig. 8).

Pass/Fail Criteria—The start position and hand grip(s) clearance shall conform to the requirements of subsection 5.1.2.6 of Specification F3021.

Precision and Bias—No information is presented about either the precision or bias of test 7-1-2-65.1.2.6 for evaluating and measuring start position and hand grip(s) clearance since the test result is non-quantitative.

5.1.2.7 *Seats Intentional/Unintentional Movement*—This test is a visual, performance, and dimensional inspection of the sample to ensure that removable/movable seats have appropriate mechanisms, for example, wheels or skids and hand grips or gripping surfaces, to enable the seat to move easily over different floor surfaces and a means of preventing unintentional movement during use.

Apparatus and Set Up—The sample shall be set up as described in Section 54 on carpet for testing the ease of moving the seat and on tile or similar flooring for testing for unintentional movement during use.

Calibration—Verify that the force measuring equipment is calibrated and accurate to within 0.5 N (0.1 lbf) over its entire range.

Procedure—Inspect the sample for skids or wheel lock mechanism. Remove/Move the seat from its active position to its storage position over carpet flooring and measure the pull force. Visually inspect for unintentional movement during use while on tile or similar flooring.

Pass/Fail Criteria—The seat intentional/unintentional movement shall conform to performance requirements of subsection 5.1.2.7 of Specification F3021.

Precision and Bias—No information is presented about either the precision or bias of test 7-1-2-75.1.2.7 for evaluating and measuring seat unintentional/intentional movement since the test result is non-quantitative.

5.1.2.8 *Physical Locating/Locking Mechanism*—This test is a performance inspection of the sample to ensure that seats with a specific exercise position have a physical locating or locking mechanism or a visual reference to indicate the correct seat alignment.

Apparatus and Set Up—The sample shall be set up as described in Section 54 with the seat removed.

Calibration—No calibration required. Performance test only.

Procedure—Verify that there is a physical locating or locking mechanism or a visual reference to indicate the correct seat alignment. Have an untrained tester move the seat into the specific exercise position, verify that the seat is in the correct position.

Pass/Fail Criteria—The seat position shall conform to the requirements of subsection 5.1.2.8 of Specification F3021.

Precision and Bias—No information is presented about either the precision or bias of test 7-1-2-85.1.2.8 for evaluating physical locating/locking mechanism since the test result is non-quantitative.

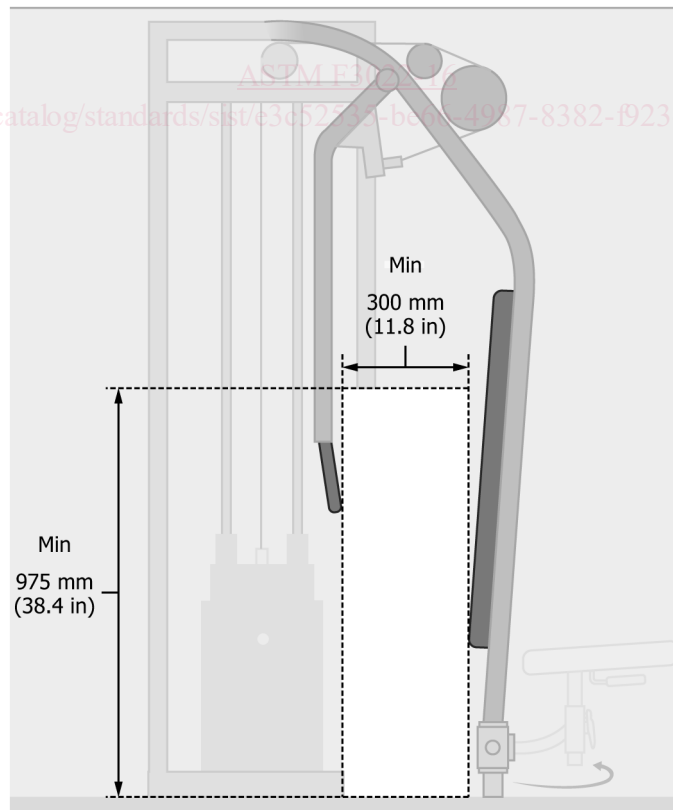

FIG. 8 Minimum Distance from Back Support to Hand Grips with Seat Removed

5.1.2.9 Bench Width and Length—This test is a dimensional inspection of the sample to ensure the dimensional compliance of the bench width and length.

Apparatus and Set Up—The sample shall be set up as described in Section 4.

Calibration—Verify that the distance measuring equipment is calibrated and accurate to within 1 mm (0.040 in.).

Procedure—Measure the width of the bench across the top of the sitting support surface from the left outer side edge to the right outer side edge at the widest point in the hip/pelvic area. Measure the length of the bench from the front edge to the back edge through the centerline.

Pass/Fail Criteria—The dimensions of the bench width and length shall conform to dimensional requirements of subsection 5.1.2.9 of Specification F3021.

Precision and Bias—No information is presented about either the precision or bias of test 5.1.2.9 for measuring bench width and length dimensions since the test result is non-quantitative.

5.1.2.10 Back Support Height and Width—This test is a dimensional inspection of the sample to ensure the dimensional compliance of the back support height and width.

Apparatus and Set Up—The sample shall be set up as described in Section 54.

Calibration—Verify that the distance measuring equipment is calibrated and accurate to within 1 mm (0.040 in.).

Procedure—Determine where the width measured from the left outer edge to the right outer edge on the back support meets minimum width requirements. Measure the height on the back support from this point along the centerline of the back support for which the minimum width requirement is continuously met (see Fig. 9).

Pass/Fail Criteria—The back support height and width shall conform to the requirements of subsection 5.1.2.95.1.2.10 of Specification F3021.

Precision and Bias—No information is presented about either the precision or bias of test 7.1.2.95.1.2.10 for measuring the back support height and width since the test result is non-quantitative.

5.1.2.11 Postural Support/Surface Padding—This test is a dimensional inspection of the sample to ensure that postural support/surfaces are cleanable and padded.

Apparatus and Set Up—The sample shall be set up as described in Section 54.

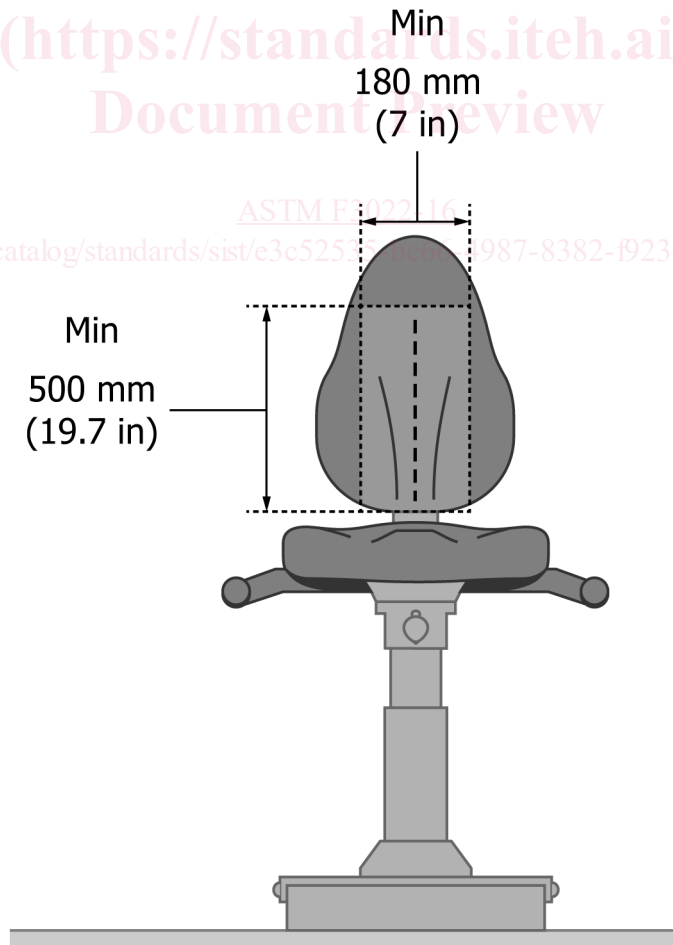

FIG. 9 Back Support Height and Depth

Calibration—Verify that the distance measuring equipment is calibrated and accurate to within 1 mm (0.040 in.).

Procedure—Verify that the postural supports/surfaces can be sanitized from sweat and other bodily fluids. Measure the depth of the foam used in each postural support/surface and verify that the hardness and density meet the specified ISO requirements.

Pass/Fail Criteria—The postural supports/surfaces padding shall conform to the requirements of subsection 5.1.2.95.1.2.11 of Specification F3021.

Precision and Bias—No information is presented about either the precision or bias of test 7.1.2.105.1.2.11 for evaluating and measuring postural support/surface padding since the test result is non-quantitative.

5.1.2.12 *Seats—Significant Color Value Contrast*—Perform the color value measurement test in 7.35.3.

5.1.3 *Adjustment Mechanisms:*

5.1.3.1 *Visible Adjustment Mechanisms*—This test is a visual and performance inspection of the sample to ensure that adjustment mechanisms required for set up are visible in a clear line of sight to the user upon approach to the equipment or from the primary exercise position, or both.

Apparatus and Set Up—The sample shall be set up as described in Section 54 with the seat in place and removed/moved.

Calibration—No calibration required. Visual/performance test only.

Procedure—Verify that the adjustment mechanisms are in a clear line of sight without obstruction from the primary exercise position with the seat in place and removed/moved. Perform set up adjustments from the approach position and the primary exercise position with the seat in place and removed/moved.

Pass/Fail Criteria—The visible adjustment mechanisms shall conform to the requirements of subsection 5.1.3.1 of Specification F3021.

Precision and Bias—No information is presented about either the precision or bias of test 7.1.3.15.1.3.1 for evaluating visible adjustment mechanisms since the test result is non-quantitative.

5.1.3.2 *Left/Right Hand Bias Adjustment Mechanisms*—This test is a performance inspection of the sample to ensure that adjustment mechanisms are not left or right hand biased.

Apparatus and Set Up—The sample shall be set up as described in Section 54 with the seat in place and removed/moved.

Calibration—No calibration required. Performance test only.

Procedure—Make all adjustments using the left hand and then repeat using the right hand with the seat in place and removed/moved.

Pass/Fail Criteria—The left/right hand bias adjustment mechanisms shall conform to the requirements of subsection 5.1.3.2 of Specification F3021.

Precision and Bias—No information is presented about either the precision or bias of test 7.1.3.25.1.3.2 for evaluating left/right hand bias adjustment mechanisms since the test result is non-quantitative.

5.1.3.3 *One Hand Adjustment Mechanisms*—This test is a performance inspection of the sample to ensure that adjustment mechanisms can be performed with one hand.

Apparatus and Set Up—The sample shall be set up as described in Section 54.

Calibration—No calibration required. Performance test only.

Procedure—Make all adjustments, except those requiring a carabiner, using only one hand.

Pass/Fail Criteria—The adjustments shall conform to the requirements of subsection 5.1.3.3 of Specification F3021.

Precision and Bias—No information is presented about either the precision or bias of test 7.1.3.35.1.3.3 for evaluating one hand adjustment mechanisms since the test result is non-quantitative.

5.1.3.4 *Adjustment Mechanism Ease of Use*—This test is a visual and performance inspection of the sample to ensure that adjustment mechanisms required for set up are easy to use.

Apparatus and Set Up—The sample shall be set up as described in Section 54.

Calibration—No calibration required. Visual/performance test only.

Procedure—Verify that the adjustment mechanisms are within reach from the primary exercise position by a 5 % size female (see Table 1). Perform set up adjustments and verify that the adjustment mechanisms can be easily inserted/removed and do not require fine finger control, excessive wrist rotation, tight grasp, or a pinch grip (see Figs. 10 and 11).

Pass/Fail Criteria—The adjustment mechanism ease of use shall conform to the requirements of subsection 5.1.3.4 of Specification F3021.

Precision and Bias—No information is presented about either the precision or bias of test 7.1.3.45.1.3.4 for evaluating adjustment mechanism ease of use since the test result is non-quantitative.

TABLE 1 Dimensions of US Civilian Male and Females^A

Dimension Name	5th Percentile Female (in.)	Mean (Average) Male (in.)	Mean (Average) Female (in.)	Mean (Average) Overall (in.)	95th Percentile Male (in.)
Height	58.9	68.21	63.10	65.66	72.6
Sitting Height, Erect	30.9	35.61	33.34	34.48	38.1

^ASource: Anthropology Research Project Staff, *Anthropometric Source Book, Volume 2. Anthropometry for Designers*, NASA Reference Publication 1024, NASA, Houston, TX, 1978.