



Designation: D7928 – 16<sup>ε1</sup>

## Standard Test Method for Particle-Size Distribution (Gradation) of Fine-Grained Soils Using the Sedimentation (Hydrometer) Analysis<sup>1</sup>

This standard is issued under the fixed designation D7928; the number immediately following the designation indicates the year of original adoption or, in the case of revision, the year of last revision. A number in parentheses indicates the year of last reappraisal. A superscript epsilon ( $\epsilon$ ) indicates an editorial change since the last revision or reappraisal.

<sup>ε1</sup> NOTE—Editorially corrected A1.4.3.1, Fig. X1.5, and Fig. X1.6 in January 2017.

### 1. Scope

1.1 This test method covers the quantitative determination of the distribution of particle sizes of the fine-grained portion of soils. The sedimentation or hydrometer method is used to determine the particle-size distribution (gradation) of the material that is finer than the No. 200 (75- $\mu\text{m}$ ) sieve and larger than about 0.2- $\mu\text{m}$ . The test is performed on material passing the No. 10 (2.0-mm) or finer sieve and the results are presented as the mass percent finer versus the log of the particle diameter.

1.2 This method can be used to evaluate the fine-grained fraction of a soil with a wide range of particle sizes by combining the sedimentation results with a sieve analysis resulting in the complete gradation curve. The method can also be used when there are no coarse-grained particles or when the gradation of the coarse-grained material is not required or not needed.

NOTE 1—The significant digits recorded in this test method preclude obtaining the grain size distribution of materials that do not contain a significant amount of fines. For example, clean sands will not yield detectable amounts of silt and clay sized particles, and therefore should not be tested with this method. The minimum amount of fines in the sedimentation specimen is 15 g.

1.3 When combining the results of the sedimentation and sieve tests, the procedure for obtaining the material for the sedimentation analysis and calculations for combining the results will be provided by the more general test method, such as Test Methods D6913 (Note 2).

NOTE 2—Subcommittee D18.03 is currently developing a new test method “Test Method for Particle-Size Analysis of Soils Combining the Sieve and Sedimentation Techniques.”

1.4 The terms “soil” and “material” are used interchangeably throughout the standard.

1.5 The sedimentation analysis is based on the concept that larger particles will fall through a fluid faster than smaller

particles. Stokes’ Law gives a governing equation used to determine the terminal velocity of a spherical particle falling through a stationary liquid. The terminal velocity is proportional to the square of the particle diameter. Therefore, particles are sorted by size in both time and position when settling in a container of liquid.

1.5.1 Stokes’ Law has several assumptions which are: the particles are spherical and smooth; there is no interference between the particles; there is no difference between the current in the middle of the container and the sides; flow is laminar; and the particles have the same density. These assumptions are applied to soil particles of various shapes and sizes.

1.6 A hydrometer is used to measure the fluid density and determine the quantity of particles in suspension at a specific time and position. The density of the soil-water suspension depends upon the concentration and specific gravity of the soil particles and the amount of dispersant added. Each hydrometer measurement at an elapsed time is used to calculate the percentage of particles finer than the diameter given by Stokes’ Law. The series of readings provide the distribution of material mass as a function of particle size.

1.7 This test method does not cover procurement of the sample or processing of the sample prior to obtaining the reduced sample in any detail. It is assumed that the sample is obtained using appropriate methods and is representative of site materials or conditions. It is also assumed that the sample has been processed such that the reduced sample accurately reflects the particle-size distribution (gradation) of this finer fraction of the material.

1.8 *Material Processing*—Material is tested in the moist or as-received state unless the material is received in an air-dried state. The moist preparation method shall be used to obtain a sedimentation test specimen from the reduced sample. Air-dried preparation is only allowed when the material is received in the air-dried state. The method to be used may be specified by the requesting authority; however, the moist preparation method shall be used for referee testing.

1.9 This test method is **not** applicable for the following soils:

<sup>1</sup> This test method is under the jurisdiction of ASTM Committee D18 on Soil and Rock and is the direct responsibility of Subcommittee D18.03 on Texture, Plasticity and Density Characteristics of Soils.

Current edition approved May 1, 2016. Published May 2016. DOI: 10.1520/D7928-16E01

1.9.1 Soils containing fibrous peat.

1.9.2 Soils containing less than approximately 5 % of fine-grained material (**Note 1**).

1.9.3 Soils containing extraneous matter, such as organic solvents, oil, asphalt, wood fragments, or similar items (**Note 3**).

**NOTE 3**—If extraneous matter, such as wood, can be easily removed by hand, it is permissible to do so. However, there may be cases where the extraneous matter is being evaluated as part of the material and it should not be removed from the material.

1.9.4 Materials that contain cementitious components, such as cement, fly ash, lime, or other stabilization admixtures.

1.10 This test method may not produce consistent test results within and between laboratories for the following soils. To test these soils, this test method must be adapted and these adaptations documented.

1.10.1 Soils that flocculate during sedimentation. Such materials may need to be treated to reduce salinity or alter the pH of the suspension.

1.10.2 Friable soils in which processing changes the gradation of the soil. Typical examples of these soils are some residual soils, most weathered shales, and some weakly cemented soils.

1.10.3 Soils that will not readily disperse, such as glauconitic clays or some dried plastic clays.

1.11 Samples that are not soils, but are made up of particles may be tested using this method. The applicable sections above should be used in applying this standard.

1.12 *Units*—The values stated in SI units are to be regarded as standard. Except the sieve designations, they are identified using the “alternative” system in accordance with Practice **E11**, such as 3-in. and No. 200, instead of the “standard” of 75-mm and 75- $\mu$ m, respectively. Reporting of test results in units other than SI shall not be regarded as non-conformance with this test method. The use of balances or scales recording pounds of mass (lbm) shall not be regarded as nonconformance with this standard.

1.13 All observed and calculated values shall conform to the guidelines for significant digits and rounding established in Practice **D6026**, unless superseded by this test method.

1.13.1 The procedures used to specify how data are collected/recorded and calculated in the standard are regarded as the industry standard. In addition, they are representative of the significant digits that generally should be retained. The procedures used do not consider material variation, purpose for obtaining the data, special purpose studies, or any considerations for the user’s objectives; and it is common practice to increase or reduce significant digits of reported data to be commensurate with these considerations. It is beyond the scope of these test methods to consider significant digits used in analysis methods for engineering data.

1.14 *This standard does not purport to address all of the safety concerns, if any, associated with its use. It is the responsibility of the user of this standard to establish appropriate safety and health practices and determine the applicability of regulatory limitations prior to use.*

## 2. Referenced Documents

### 2.1 ASTM Standards:<sup>2</sup>

- C702** Practice for Reducing Samples of Aggregate to Testing Size
- D653** Terminology Relating to Soil, Rock, and Contained Fluids
- D854** Test Methods for Specific Gravity of Soil Solids by Water Pycnometer
- D1140** Test Methods for Determining the Amount of Material Finer than 75- $\mu$ m (No. 200) Sieve in Soils by Washing
- D2216** Test Methods for Laboratory Determination of Water (Moisture) Content of Soil and Rock by Mass
- D2487** Practice for Classification of Soils for Engineering Purposes (Unified Soil Classification System)
- D2488** Practice for Description and Identification of Soils (Visual-Manual Procedure)
- D3740** Practice for Minimum Requirements for Agencies Engaged in Testing and/or Inspection of Soil and Rock as Used in Engineering Design and Construction
- D4220/D4220M** Practices for Preserving and Transporting Soil Samples
- D4318** Test Methods for Liquid Limit, Plastic Limit, and Plasticity Index of Soils
- D4753** Guide for Evaluating, Selecting, and Specifying Balances and Standard Masses for Use in Soil, Rock, and Construction Materials Testing
- D6026** Practice for Using Significant Digits in Geotechnical Data
- D6913** Test Methods for Particle-Size Distribution (Gradation) of Soils Using Sieve Analysis
- E11** Specification for Woven Wire Test Sieve Cloth and Test Sieves
- E100** Specification for ASTM Hydrometers
- E126** Test Method for Inspection, Calibration, and Verification of ASTM Hydrometers

## 3. Terminology

### 3.1 Definitions:

3.1.1 For definitions of common technical terms used in this standard, refer to Terminology **D653**.

### 3.2 Definitions of Terms Specific to This Standard:

3.2.1 *reduced sample, n*—the minus  $\frac{3}{8}$ -in. (9.5-mm) sieve or finer material that has been separated from the sample and then worked to reduce the mass while still having sufficient quantity to meet the minimum mass requirements of **Table 1**.

3.2.2 *sample, n*—material collected without limitation on the total mass or size range of particles meeting the minimum mass requirements provided in **Table 1**.

3.2.3 *sedimentation sample, n*—the minus No. 10 (2.0-mm) or finer material that is separated from the reduced sample using the separation sieve from which the sedimentation specimen and water content are obtained.

<sup>2</sup> For referenced ASTM standards, visit the ASTM website, [www.astm.org](http://www.astm.org), or contact ASTM Customer Service at [service@astm.org](mailto:service@astm.org). For *Annual Book of ASTM Standards* volume information, refer to the standard’s Document Summary page on the ASTM website.

**TABLE 1 Minimum Dry Mass Requirements**

Maximum Particle Size of Material (99% or more passing)		Minimum Dry Mass	Comments on separating and splitting requirements for sample reduction
Sieve Designation	Particle Size, mm		
6 in.	152.4	500 kg	Several separations
3 in.	76.2	70 kg	Several separations
1 in.	25.4	3 kg	At least one separation
¾ in.	19.1	1.3 kg	Most likely one separation
⅜ in.	9.5	165 g	Separation for sedimentation analysis
No. 10	2.0	50 g	Splitting only

3.2.4 *sedimentation specimen, n*—the material obtained from the sedimentation sample having a maximum particle-size no greater than the No. 10 (2.0-mm) sieve to be used in the sedimentation test and in sufficient quantity to satisfy the minimum mass requirements of **Table 1**.

3.2.5 *separation sieve, n*—the No. 10 (2.0-mm) sieve or finer (**Note 4**) used to separate the reduced sample to obtain the material for the sedimentation sample.

**NOTE 4**—The methodology for using a sieve finer than the No. 10 (2.0 mm) is not defined in this standard. The methodology used to obtain a representative sample using a sieve finer than the No. 10 (2.0 mm) is not the same as obtaining the representative sample using the No. 10 (2.0 mm) sieve as presented in this standard. Additional effort or steps are necessary to make sure the material passing the finer sieve adequately represents the sample. Such additional effort or steps should be documented if using a sieve finer than the No. 10 (2.0 mm) sieve to obtain the sedimentation specimen.

#### 4. Summary of Test Method

4.1 This test method is used to determine the particle-size distribution (gradation) of material finer than the No. 200 (75- $\mu$ m) sieve as a percentage of the mass used in the sedimentation test.

4.2 When the source material contains particles larger than the ¾-in. (9.5-mm) sieve, a reduced sample passing the ⅜-in. (9.5-mm) sieve shall be obtained using techniques presented in Test Methods **D6913** or another standard. This reduced sample shall meet the minimum mass requirements in **Table 1** for the ⅜-in. (9.5-mm) sieve. The material is processed using the moist (referee) preparation method unless the material is received in the air-dried state.

4.3 The entire reduced sample is separated using the separation sieve. The sedimentation sample is then split to obtain the appropriate mass for the sedimentation test specimen and a water content test specimen.

4.4 The sedimentation test specimen is mixed with a dispersing agent and test water. The slurry is allowed to condition and is then thoroughly mixed and placed in a cylinder with additional test water. Readings are taken with a hydrometer and thermometer over specific time intervals.

4.5 The mass of particles passing specified particle diameters are calculated and recorded. The results produce a tabulation of particle size versus percent passing that can be graphically presented as a gradation curve. The plot is typically expressed as percent passing/finer than the separation sieve size versus the log of the particle size in millimetres.

#### 5. Significance and Use

5.1 Particle-size distribution (gradation) is a descriptive term referring to the proportions by dry mass of a soil distributed over specified particle-size ranges. The gradation curve generated using this method yields the amount of silt and clay size fractions present in the soil based on size definitions, not mineralogy or Atterberg limit data.

5.2 Determination of the clay size fraction, which is material finer than 2  $\mu$ m, is used in combination with the Plasticity Index (Test Methods **D4318**) to compute the activity, which provides an indication of the mineralogy of the clay fraction.

5.3 The gradation of the silt and clay size fractions is an important factor in determining the susceptibility of fine-grained soils to frost action.

5.4 The gradation of a soil is an indicator of engineering properties. Hydraulic conductivity, compressibility, and shear strength are related to the gradation of the soil. However, engineering behavior is dependent upon many factors, such as effective stress, mineral type, structure, plasticity, and geological origin, and cannot be based solely upon gradation.

5.5 Some types of soil require special treatment in order to correctly determine the particle sizes. For example, chemical cementing agents can bond clay particles together and should be treated in an effort to remove the cementing agents when possible. Hydrogen peroxide and moderate heat can digest organics. Hydrochloric acid can remove carbonates by washing and Dithionite-Citrate-Bicarbonate extraction can be used to remove iron oxides. Leaching with test water can be used to reduce salt concentration. All of these treatments, however, add significant time and effort when performing the sedimentation test and are allowable but outside the scope of this test method.

5.6 The size limits of the sedimentation test are from about 100  $\mu$ m to about 1  $\mu$ m. The length of time required to obtain a stable initial reading on the hydrometer controls the upper range of results, and the test duration controls the lower range.

5.7 The shape and density of the grains are important to the results. Stokes' Law is assumed to be valid for spherical particles even though fine silt- and clay-sized particles are more likely to be plate-shaped and have greater mineral densities than larger particles.

**NOTE 5**—The quality of the result produced by this standard is dependent on the competence of the personnel performing it, and the suitability of the equipment and facilities used. Agencies that meet the criteria of Practice **D3740** are generally considered capable of competent and objective testing/sampling/inspection/etc. Users of this standard are

cautioned that compliance with Practice **D3740** does not in itself assure reliable results. Reliable results depend on many factors; Practice **D3740** provides a means of evaluating some of those factors.

## 6. Apparatus

6.1 *Hydrometer*—ASTM hydrometer type 151H or 152H. These hydrometers shall conform to the requirements in Specification **E100**. See **Annex A1**.

6.2 *Sedimentation Cylinder*—At least two glass cylinders essentially having a height of about 457 mm, an inside diameter between 55 and 64 mm, and a capacity of 1,000 mL. The cylinders shall have an indication mark at  $1,000 \pm 5$  mL. One cylinder is used for the soil suspension and the other one can be used as the control cylinder or the wash cylinder. The control cylinder shall have the same amount of dispersant as the soil suspension cylinder. See **Annex A1**.

6.3 *Separation Sieve*—No. 10 (2-mm) or finer sieve used to separate the reduced sample. This sieve is subjected to rough operation and shall not be used for quantitative grain size analysis.

6.4 *Thermometric Device*—A thermometric device capable of measuring the temperature range within which the test is being performed readable to  $0.5^\circ\text{C}$  or better and having an accuracy of at least  $\pm 0.5^\circ\text{C}$ . The thermometric device must be capable of being immersed in the suspension and reference solutions to a depth ranging between 25 and 80 mm. Full immersion, also known as complete or total immersion thermometers, shall not be used. The thermometric device shall be standardized by comparison to a nationally or internationally traceable thermometric device and shall include at least one temperature reading within the range of testing. The thermometric device shall be standardized at least once every twelve months. The same thermometric device shall be used for all measurements.

6.5 *Timing Device*—A clock, stopwatch, digital timer, or comparable device readable to one second or better.

6.6 *Balance*—Balances shall conform to the requirements of Specification **D4753**.

6.6.1 To determine the mass of the specimen, the balance shall have readability without estimation of 0.01 g. The capacity of this balance will need to exceed the mass of the container plus soil used to contain the soil suspension after the completion of the sedimentation test. In general, a balance with a minimum capacity of 1,800 g is sufficient.

6.7 *Drying Oven*—Vented, thermostatically controlled oven capable of maintaining a uniform temperature of  $110 \pm 5^\circ\text{C}$  throughout the drying chamber. These requirements typically require the use of a forced-draft oven.

6.8 *Plate*—A clean, nonporous, smooth, solid surface that is large enough to pile and split about 500 g of material. The surface shall not be made of any type of paper product.

6.9 *Specimen-Mixing Container*—A 250-mL glass beaker or equivalent inert container with enough capacity to hold the specimen, the test water, and dispersant.

6.10 *Temperature Maintaining Device*—Unless otherwise specified by the requesting agency, the standard test tempera-

ture shall be in the range of  $22 \pm 5^\circ\text{C}$ . In addition, the temperature of the soil suspension shall not vary more than  $\pm 2^\circ\text{C}$ . Normally, this temperature maintenance is accomplished by performing the test in a room with a relatively constant temperature. If such a room is not available, the cylinders shall be placed in an automatically temperature controlled insulated chamber or water bath that maintains a temperature within the tolerance specified above.

6.11 *Soil Suspension Oven-Drying Container*—A container having smooth walls and capable of holding approximately 1.5-L of the soil suspension. This container shall have a tight fitting lid or fit into a desiccator, to prevent moisture gain during cooling of the oven-dried specimen.

6.12 *Dispersion Apparatus*—Use one of the following devices to disperse the specimen; however for referee testing, the stirring apparatus shall be used.

6.12.1 *Stirring Apparatus (Referee)*—A mechanically operated stirring device in which a suitably mounted electric motor turns a vertical shaft at a minimum speed of 10,000 rpm without load. The shaft shall be equipped with a replaceable stirring paddle made of metal, as shown in **Fig. 1**. The shaft shall be of such length that the stirring paddle will operate between 19.0-mm and 37.5-mm above the bottom of the dispersion cup (**Note 6**).

**NOTE 6**—The SI units presented are basically soft conversions of the inch-pound units; other rationalized SI units should be acceptable providing they meet the requirements established by the inch-pound apparatus.

6.12.1.1 *Dispersion Cup*—A special dispersion cup conforming to either of the designs shown in **Fig. 2** shall be provided to hold the sample while it is being dispersed. The cup shall contain two sets of three long baffle rods and two sets of three short baffle rods rigidly mounted to the interior sides of the cup. This cup is used with the stirring apparatus.

6.12.2 *Air Jet Dispersion Device (Optional)*—A tube type or other comparable device that uses compressed air to disperse the slurry (**Note 7**). The device requires an air source capable of providing up to  $0.0024 \text{ m}^3/\text{s}$  of air to operate the device, such that pressures of 69 and 172 kPa can be achieved. The device shall be fitted with a pressure gauge on the line between the device and the air source. Water may condense in the lines when not in use and this water must be removed. There are two ways to remove the water: use of a water trap or purging the lines before use. If a water trap is used, it shall be installed on the air line in such a manner to prevent condensed water from entering the slurry. This device shall not be used in referee testing.

**NOTE 7**—Use of this device or others, causes differing amounts of dispersion and should be used with caution. Information on how to appropriately use this device should be obtained from the manufacturer.  $0.0024 \text{ m}^3/\text{s}$  is equivalent to  $5 \text{ ft}^3/\text{min}$ . The device typically needs at least  $0.0009 \text{ m}^3/\text{s}$  ( $2 \text{ ft}^3/\text{min}$ ) to operate and therefore, some small air compressors are not capable of supplying sufficient air to operate the device.

6.13 *Agitator (Optional/Referee)*—A hand-held device to mix the soil suspension in the sedimentation cylinder prior to testing, as shown in **Fig. 3**. The agitator must not have any type of metal, such as a screw head, protruding from the bottom of the disk. This device shall be used for referee testing.

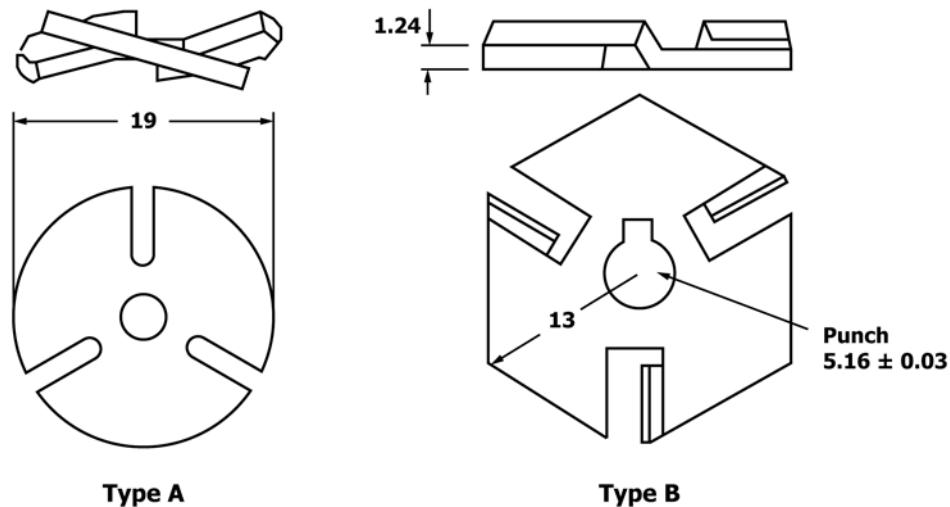

Dimensional Equivalents <sup>4</sup>		
mm		in.
19		0.75
13		0.51
5.16 ± 0.03		0.203 ± 0.001
1.24		0.049 (No. 18 BW Ga.)

Note: All dimensions are shown in millimetres unless otherwise noted.

<sup>4</sup>The SI units presented are basically soft conversions of the inch-pound units; other rationalized SI units should be acceptable providing they meet the technical requirements established by the inch-pound apparatus.

FIG. 1 Detail of Stirring Paddles

6.14 *Agitation of the Soil Slurry*—Any of the following items may be used to break up the soil aggregations as described in 11.1:

6.14.1 *Erlenmeyer Flask*—A glass flask having a capacity between 250-mL and 500-mL.

6.14.2 *Dispersion Shaker*—A platform, wrist action or similar type shaker having a gyratory, orbital, reciprocating, or similar motion to assist in the dispersion process by continuously agitating the soaking soil.

6.14.3 *Ultrasonic Water Bath*—The ultrasonic water bath must be large enough to hold a beaker or flask containing the soil slurry to be agitated for use in the sedimentation test. The water level in the bath should be equal to or higher than the water level in the specimen container.

6.15 *Desiccator (Optional)*—A desiccant containing device of suitable size used to prevent moisture gain during cooling of the oven-dried specimen.

6.16 *Mortar and Rubber-Covered Pestle (Optional)*—Apparatus suitable for breaking up aggregations of air-dried soil particles without breaking individual particles.

6.17 *Miscellaneous Items*—Items such as a wash/rinse bottle (squirt bottle), rubber scraper, spatula, and stirring rod may be useful.

## 7. Reagents and Materials

7.1 *Sodium Hexametaphosphate (NaPO<sub>3</sub>)<sub>6</sub>*—Also referred to as sodium metaphosphate is the dispersion agent (deflocculant) required to prevent the fine particles in suspension from coalescing or flocculating (Note 8). Consult the Safety Data Sheet (SDS) for specific information regarding this chemical.

7.2 *Isopropyl Alcohol*—Also referred to as isopropanol alcohol or rubbing alcohol is used as a foam inhibitor. Commercially available in concentrations ranging from 70 % to 99 %.

7.3 *Test Water*—Distilled or demineralized water is the only permissible test fluid. The use of tap water is not permitted.

NOTE 8—Fine-grained soils requiring the use of a dispersant are those that do not readily slake in water, such as some highly plastic clays and most tropical soils. Typically, 5 grams per test of dispersant is used to prevent flocculation and is added directly to the soil, such that the concentration will equal 5 g/L in the final soil suspension volume. The chemical formula for the dispersant shown above is approximate.

## 8. Sampling

8.1 *General*—This test method does not address, in any detail, procurement of the sample. It is assumed the sample is obtained using appropriate methods and is representative of the material under evaluation. However, the testing agency shall preserve all samples in accordance with Practice D4220/D4220M, Group B, except if the as-received sample does not meet those requirements. In which case, the water content of the material does not have to be maintained.

8.2 Where data from this test are to be used for correlation with other laboratory or field test data, use the same material as used for these tests where possible and as much is practical.

8.3 The sample can be from a variety of sources and contain a wide range of particle sizes. Typically, samples for particle-size analysis are obtained from the following sources: large bags or buckets, small bags, jar samples, tube samples, or specimens from other tests, such as consolidation, hydraulic conductivity or strength tests. In some cases, such as compaction testing, prior testing may have caused a reduction in

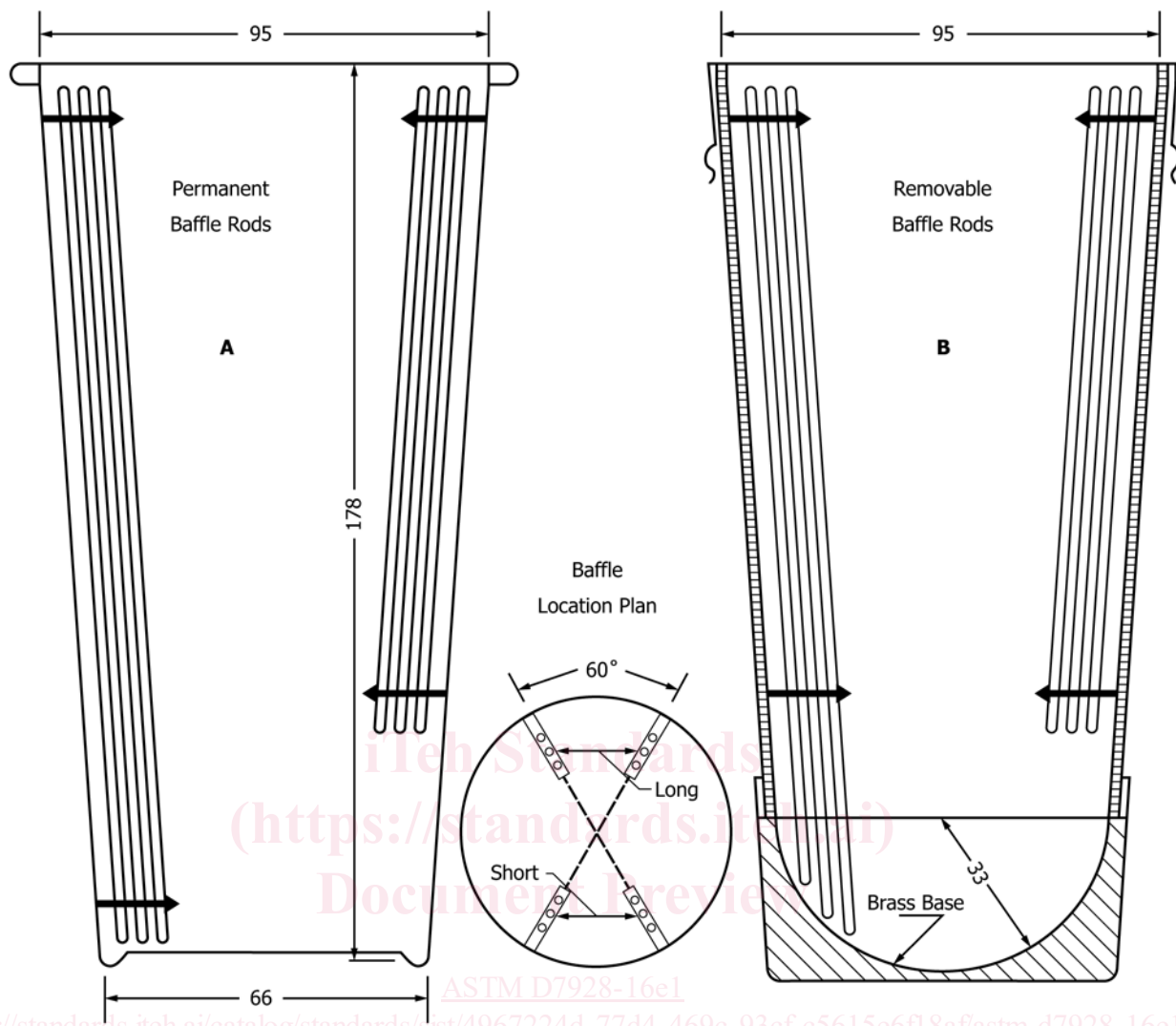

Dimensional Equivalents<sup>4</sup>

mm	in.
33	1.30
66	2.60
95	3.75
178	7.01

Note: All dimensions are shown in millimetres unless otherwise noted.

<sup>4</sup>The SI units presented are basically soft conversions of the inch-pound units; other rationalized SI units should be acceptable providing they meet the technical requirements established by the inch-pound apparatus.

FIG. 2 Dispersion Cup

particle sizes; therefore, it may be required to obtain a sample of the original material, the degraded sample, or both. Test Methods D6913, Section 9, gives additional information regarding sampling from the different sources.

8.3.1 Preserve the sample at its original moisture condition unless excluded above, and at no time shall the sample be allowed to undergo undesirable temperature changes such as freezing or heating.

8.4 When the sample contains particles larger than the 3/8-in. (9.5-mm) sieve, it shall be processed to obtain the reduced sample. If particle-size separation is necessary, process the

sample to meet this requirement using the separation procedures provided in Test Methods D6913.

8.4.1 The reduced sample shall have a maximum particle size that passes through the 3/8-in. (9.5-mm) sieve.

8.4.2 The mass of the reduced sample shall meet or exceed the mass requirements given in Table 1.

8.4.3 Preserve the original moisture condition of the reduced sample, and at no time shall the reduced sample be allowed to undergo undesirable temperature changes such as freezing or heating.

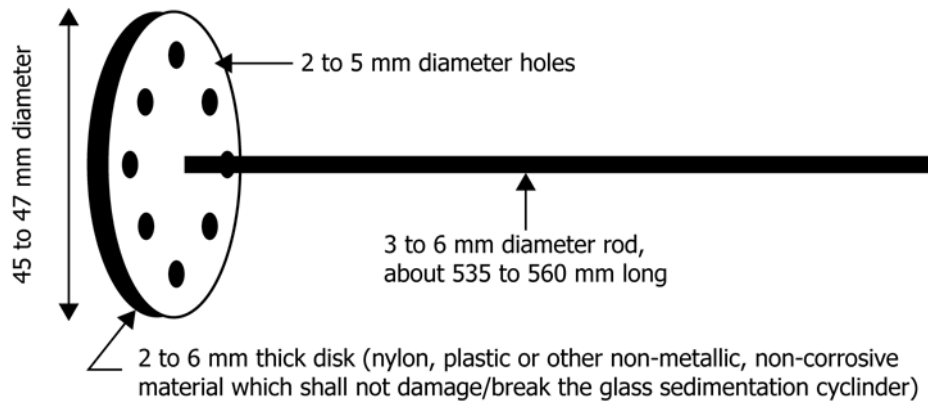

FIG. 3 Detail of Agitator

### 9. Preparation of the Test Specimen

9.1 *Specimen Procurement*—This standard presents two preparation methods to obtain the sedimentation specimen from the reduced sample: moist and air-dried. In these preparation methods, moist and air-dried refers to the condition of the material or sample as it is being reduced to an appropriate particle size and mass. The test shall not be performed on oven-dried material. The moist preparation method shall be used for referee testing and for samples not received in the air-dried state. The air-dried method shall only be used on materials received in the air-dried state (Note 9). Since some fine-grained, air-dried soils aggregate, a mortar and rubber covered pestle is used to break up aggregations. Care must be taken to avoid disintegration or reduction of individual particles. Use only enough force as necessary to break up the aggregations without destroying the individual particles. Additional guidance for splitting material to obtain a representative specimen using a splitter, quartering, or moist stockpile sampling is given in Practice C702, Methods A, B, and C, respectively.

NOTE 9—Air drying causes irreversible changes to the clay particles that cause permanent flocculations and decreases the fine fraction.<sup>3</sup>

9.2 *Moist Preparation (Referee)*—This preparation method shall be used for materials not received in the air-dried state. This method is especially important for any soil whose properties are altered due to drying such as, most organic soils, many highly plastic fine-grained soils, tropical soils and soils containing halloysite. The material is thoroughly mixed to obtain a uniform reduced sample. Intact fine-grained samples should be chopped/reduced into small pieces, less than approximately 13 mm, and mixed to make uniform. Test water can be added to assist in making a uniform sample. There is no need to process the fine-grained materials through a sieve.

9.3 *Air-Dried Preparation*—This preparation method shall only be used if the sample is received in the dried condition. In order to obtain a uniform reduced sample, the sample is blended at room temperature.

<sup>3</sup> Sridharan, A., Jose, B.T., and Abraham, B.M., Technical Note on “Determination of Clay Size Fraction of Marine Clays,” *Geotechnical Testing Journal*, GTJODJ, Vol. 14, No. 1, March 1991, pp. 103-107.

9.4 If the reduced sample contains particles which are larger than the No. 10 (2.0-mm) sieve, the material shall be separated using a No. 10 (2.0-mm) or finer sieve. Process the entire reduced sample over the No. 10 (2.0-mm) or finer sieve using a rubber scraper and, if needed, test water to aid in working the material through the sieve. Check that the material retained on the sieve does not contain aggregations of finer particles. Any aggregations should be broken and passed through the sieve. It is not necessary that the separation be totally complete but the material passing the sieve shall be representative. The material passing the separation sieve is termed the sedimentation sample and shall meet the minimum mass requirement of Table 1. Record the separation sieve size that is used to separate the sample.

9.5 Estimate the amount of moist mass needed for the sedimentation test using the equation (Note 10):

$$M_{mest} = H_c \times \left( \frac{100}{\%est} \right) \times \left( 1 + \left( \frac{w_{cest}}{100} \right) \right) \quad (1)$$

where:

- $M_{mest}$  = estimated moist mass, nearest 1 g,
- $H_c$  = hydrometer capacity, g (either 45 for 151H or 55 for 152H),
- $\%est$  = estimated percentage of material passing the No. 200 (75- $\mu$ m) sieve, nearest 1 %, and
- $w_{cest}$  = estimated water content, nearest 1 %.

NOTE 10—The mass of the sedimentation test specimen should be selected based on the amount of material that will be in suspension at the time of the first reading. The capacity of the 152H hydrometer is about 55 g of dry soil and the capacity of the 151H is about 45 g. The wet mass should be adjusted to account for the water content and the fraction of particles larger than the No. 200 (75- $\mu$ m) sieve. For example, if the water content is estimated at 20 %, using a 151H hydrometer, and an estimated percent passing the No. 200 (75- $\mu$ m) sieve of 95 %, the estimated moist mass needed is 57 g.

9.6 If the sedimentation sample contains sufficient material, then split or quarter the sedimentation sample into at least two portions: one for the water content determination and one for the sedimentation test. The water content specimen shall contain  $50 \pm 10$  g of material.

9.7 If the sedimentation sample has limited material, reduce the mass to obtain the sedimentation specimen. Do not obtain a water content specimen. Obtain the dry mass,  $M_d$ , of the

sedimentation specimen at the end of the test as discussed in 11.12 and calculated in 12.1.2.

NOTE 11—If there is enough material after splitting/quartering to obtain the necessary masses for both the sedimentation and water content specimens, the sedimentation sample is considered to have sufficient material. If there is not enough material to obtain both the necessary masses of the specimens, the sedimentation sample is considered to have limited material.

9.8 Record the mass of the moist soil,  $M_m$ , used for the sedimentation test to the nearest 0.01 g.

9.9 Place the sedimentation specimen in the specimen-mixing container and record the identification of the specimen-mixing container.

9.10 If sufficient material is available, immediately use the other specimen for determination of the water content in accordance with Test Methods D2216, and record the water content,  $w_c$ , to the nearest 0.1 %.

## 10. Verification/Preparation of Apparatus

10.1 *Hydrometer*—Check and record the dimensions of the 151H or 152H hydrometers as presented in Annex A1 in accordance with the interval listed in the Annex. The hydrometer shall be free of cracks and chips, which can compromise the integrity of the hydrometer. The body and stem of a hydrometer seldom change over time, unless they have been subjected to corrosive materials or have been damaged, that is, chipped or cracked. They only need to be checked before use or after damage has been suspected or seen. Since it is possible for the paper scale inside the hydrometer stem to slide down, the length of the stem above and below the top and bottom graduations, respectively, as well as the hydrometer reading in the test water, shall be checked and documented according to the interval presented in Annex A1 to make sure the scale has remained in its proper place. If the scale has moved, the hydrometer shall be replaced.

10.1.1 *Hydrometer Readings*—Hydrometer readings are taken to the nearest  $\frac{1}{4}$  division (Note 12). Reading the hydrometer can be difficult. A properly placed hydrometer should neither bob nor rotate appreciably when released in the soil suspension. It is important for the stem to be dry and clean when inserting it into the soil suspension. If the stem is wet above the reading point it will add mass to the hydrometer causing the reading to be too low. If the stem is not clean, variations in the meniscus rise will result. In this application, the hydrometers are always read at the top of the meniscus for the reason stated in 10.3.

NOTE 12—Reading the 152H hydrometer to the nearest  $\frac{1}{4}$  division during the first 5 to 8 minutes of the test can be difficult. During that time it is acceptable to read the 152H hydrometer to the nearest  $\frac{1}{2}$  division.

10.1.2 To insert the hydrometer correctly do the following: First, make sure the stem is dry. Then, gently hold it by the stem with one or both hands and slowly lower it to the depth at which it just floats. This insertion process should take between 5 to 15 seconds.

10.2 *Temperature-Density Correction*—During a test, the suspension fluid density changes, therefore calculations for the quantity of particles in suspension must account for fluid

density changes due to temperature, presence of dispersant and the meniscus rise. The temperature-density correction is shifting the hydrometer scale, which is factory set for distilled water at 20°C. There are two ways to determine this correction: take companion measurements in a control cylinder filled with the reference solution during the testing or generate a reusable, calibration relationship. Both options require the use of a reference solution composed of test water and the same amount of dispersant used in the sedimentation test cylinder. The meniscus correction is automatically accounted for in the temperature-density correction for both options by consistently reading the hydrometer at the top of the meniscus as described in 10.3.

10.2.1 *Reference Solution*—The reference solution shall be prepared with the same amount of dispersant as the soil suspension. Fill a control cylinder to the 1,000 mL mark with a mixture of test water and the same amount of dispersant used in the soil suspension cylinder. The test water and dispersant shall be well mixed such that no visible crystals can be seen and the reference solution shall be agitated to make sure the dispersant is adequately mixed throughout the control cylinder.

10.2.1.1 *Companion Measurements*—Use a control cylinder filled with the reference solution in conjunction with the soil suspension cylinder to obtain the correction. Position the control cylinder in the same temperature controlled location as the test cylinders so that all cylinders are at or near the same temperature. For each hydrometer and temperature reading taken in the soil suspension cylinder, take a corresponding hydrometer reading and temperature reading in the control cylinder. However, it is permissible for one control cylinder hydrometer reading taken at the start of the sedimentation test to be used for the initial series of time readings in the soil suspension up to 30 minutes. It is also permissible for one control cylinder temperature reading taken at the start of the sedimentation test to be used for the initial series of time readings in the soil suspension up to the first 30 minutes if the temperature changes in the soil suspension cylinder vary less than 0.5°C between each temperature reading. Record the elapsed time and the hydrometer and temperature readings of the control cylinder on the data sheet(s) only when measured (Note 13).

NOTE 13—Readings taken in one control cylinder may be used for multiple test cylinders. Therefore, if the hydrometer and temperature readings in the control cylinder are only taken once during the first 30 minutes of the test, only that reading is recorded on each of the data sheet(s) to which it applies. These measured readings are not to be written in for the other times during the first 30 minutes when a measurement was not actually determined.

10.2.2 *Calibration Relationship*—This option generates a general calibration relationship between the hydrometer reading of a control cylinder filled with the reference solution and the temperature, which eliminates the need for companion measurements during the test. A temperature-based general calibration relationship is required and established for each hydrometer. A sedimentation cylinder is filled to the 1,000 mL mark with test water with the same amount of dispersant used in the soil suspension. Be sure the solution is thoroughly mixed and the temperature is allowed to equilibrate. Then insert the hydrometer as described in 10.1.2. Take the reading at the top



of the meniscus and record this reading and the temperature of the solution. Rinse the hydrometer well with test water between readings and dry it prior to taking the next reading. Increase/Decrease the temperature of the cylinder, allow it to come to temperature equilibrium and repeat the measurement process. Take at least five different hydrometer and temperature readings within the range of temperatures expected during the sedimentation test. Calculate the constant A or B as discussed below.

10.2.2.1 The 151H hydrometer measures the specific gravity of the fluid relative to distilled water at 20°C. The calibration measurements are used to compute the constant A in the following equation. The standard deviation of the five measurements shall be less than 0.0005. The average value of A is used when computing the temperature-density correction.

$$A = R_{151,t} + (7.784 \times 10^{-6} \times T_t) + (4.959 \times 10^{-6} \times T_t^2) \quad (2)$$

where:

- A = average specific gravity shift (151H hydrometer), nearest 0.0001,
- $R_{151,t}$  = 151H specific gravity hydrometer at reading,  $t$ , in reference solution, readable to 0.00025 or better,
- $T$  = temperature at reading,  $t$ , readable to 0.5°C or better, and
- $t$  = subscript indicating the reading number during calibration.

10.2.2.2 The 152H hydrometer measures the mass of particles (specific gravity of 2.65) in a suspension of distilled water at 20°C. The temperature-density correction provides the offset mass reading for the hydrometer for a specific temperature and dispersant concentration. The calibration measurements are used to compute the constant B in the following equation. The standard deviation of the 5 measurements shall be less than 0.5 g/L. The average value of B is used when computing the temperature-density correction.

$$B = R_{152,t} + (1.248 \times 10^{-2} \times T_t) + (7.950 \times 10^{-3} \times T_t^2) \quad (3)$$

where:

- B = average mass reading shift (152H hydrometer), nearest 0.1,
- $R_{152,t}$  = mass in reference solution hydrometer at reading,  $t$ , readable to 0.25 g/L or better,
- $T$  = temperature at reading,  $t$ , readable to 0.5°C or better, and
- $t$  = subscript indicating the reading number during calibration.

NOTE 14—The equations relating the hydrometer readings to temperature are based on the same water density-temperature expression as used in Test Methods D854. For the 151H specific gravity hydrometer, the constants in the water density-temperature equation from Test Methods D854 are divided by the density of water at 20°C (0.99821 g/mL). For the 152H mass in suspension hydrometer, the constants are multiplied by 1606 setting the scale to read mass of solids in solution for a particle specific gravity of 2.65.

10.3 *Meniscus Correction*—Hydrometers are designed to be read at the fluid surface, however, the fluid is wetting to the glass such that the soil suspension will rise up the hydrometer making a reading at the fluid surface impossible at times. It is common practice to read the hydrometer at the top of the meniscus and it must be taken there even when it is possible to

see through the soil suspension. The meniscus rise has a small impact on the effective depth determination since the reading is taken slightly above the surface of the suspension. This rise causes a change to the third significant digit in the computed particle size. The meniscus correction is performed before initial use of the hydrometer and after damage has been suspected or noticed.

10.3.1 The meniscus correction,  $C_m$ , as shown in Fig. 4, is determined by inserting the hydrometer with a clean and dry stem and without bobbing into the test water with the proper amount of dispersant. The reading at the top of the meniscus and the reading where the plane of water surface intersects the stem are recorded. The difference between these two readings is the meniscus correction,  $C_m$ . In accordance with Test Method E126, the latter reading shall be obtained using the following guidance. Observe a point slightly below the plane of the water surface and raise the line of vision until this surface, seen in an ellipse, becomes a straight line. The point where this line cuts the hydrometer scale is the hydrometer reading. Holding a white card behind the cylinder just below the water level will improve the visibility of the surface. The hydrometer readings shall be recorded to the nearest ¼ division. The meniscus correction is a positive number for either hydrometer used.

10.4 *Effective Depth*—The effective depth, also referred to as “true depth,” is used in the calculation of the particle fall distance for each reading. The effective depth is defined as the center of (volume) buoyancy of the hydrometer to the surface of the soil suspension. The equation to calculate the effective depth when the hydrometer is inserted and removed between readings requires certain dimensional measurements in order to do the calculation. Refer to Fig. 5.

10.4.1 Determine and record the volume of the hydrometer bulb,  $V_{hb}$ , to the nearest 1 cm<sup>3</sup> using the procedure given in Annex A1.3.4. The bulb includes everything from the bottom tip up to the base of the stem.

10.4.2 Determine and mark the center of (volume) buoyancy,  $c_b$ , using the procedure given in A1.3.5.

10.4.3 Measure the distance between the center of (volume) buoyancy,  $c_b$ , and the maximum hydrometer reading  $H_{r2}$ , as well as the minimum hydrometer reading,  $H_{r1}$ . Record both values to the nearest 0.1 cm. Refer to Fig. 5.

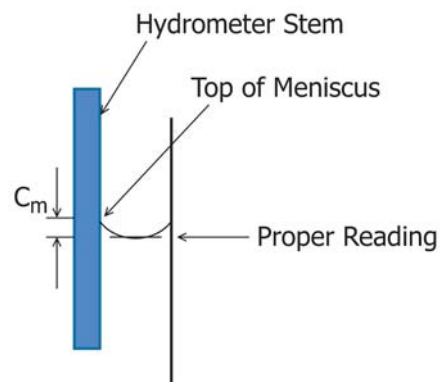

FIG. 4 Meniscus Correction Diagram

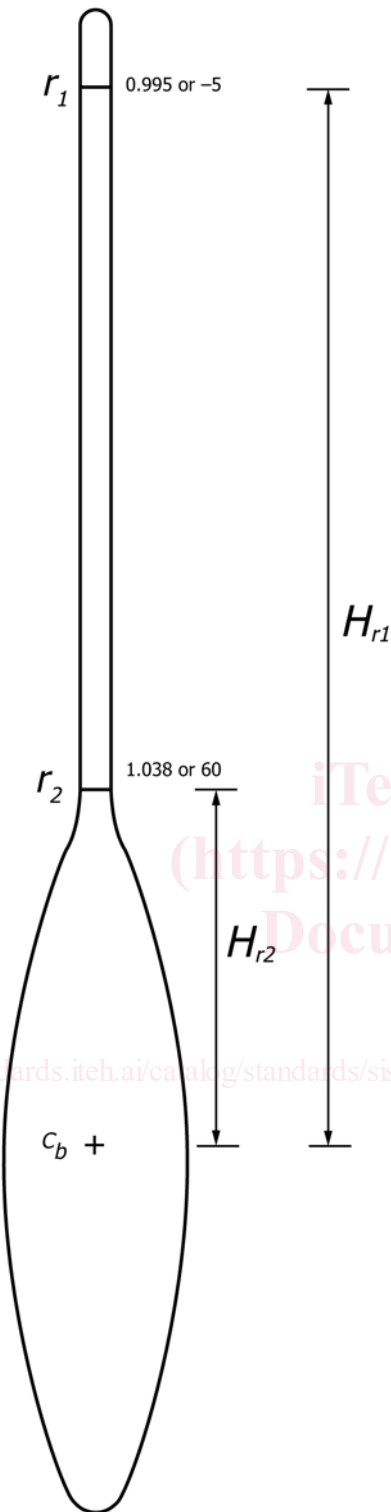

FIG. 5 Effective Depth Dimensional Measurements

10.4.4 Measure and record the inside cross-sectional area of the sedimentation cylinder,  $A_c$ , to the nearest 0.1 cm<sup>2</sup> using the procedure given in A1.4.2.1.

10.5 *Sedimentation Cylinder*—Check and record the dimensions of the sedimentation cylinders as presented in Annex A1 in accordance with the interval presented in Annex A1.

10.6 *Sieves*—See Practice E11 for the verification requirements of the sieves used in this test method.

10.7 *Miscellaneous*—The ancillary equipment used in conjunction with these test methods shall be calibrated/verified/checked according the intervals listed in Practice D3740 and performed in accordance with their applicable standards.

### 11. Procedure

11.1 Add 5.0 ± 0.1 g of sodium hexametaphosphate to the sedimentation specimen in the specimen-mixing container obtained in 9.9 or dissolve this amount of dispersant in 100 mL of test water and add it to the sedimentation specimen. Record to the nearest 0.01 g the actual amount of dispersant,  $M_{disp}$ , placed in the container or dissolved in the test water. If added directly to the sedimentation specimen, add at least 100 mL of test water to the specimen and dispersant to form a slurry of milkshake consistency. The amount of test water to be added during this step should be sufficient enough only to facilitate the process of breaking apart the soil aggregations. Mix the contents with a spatula or similar device until all of the soil aggregations are broken-up (Note 15).

NOTE 15—If hand mixing is not efficient, use a 250 to 500 mL Erlenmeyer flask along with either a wrist or orbital dispersion (mechanical) shaker to vigorously agitate the soil slurry in a minimum of 150 mL of test water for a few hours or until all the soil aggregations are broken-up. Be aware the dispersion cup has a capacity of about 400 mL and the stirring apparatus is only efficient in dispersing soil aggregations that will pass between the baffle rods. An ultrasonic water bath, along with the flask, may also be used to agitate the slurry.

11.2 Prior to the overnight conditioning period, disperse the slurry using either the stirring apparatus or an air jet device.

11.2.1 If using the stirring apparatus, transfer the slurry to the dispersion cup. Use a wash/rinse bottle filled with test water to aid in the transfer and make sure all of the slurry has been transferred to the dispersion cup. Add additional test water as necessary such that the cup is half full, then use the stirring apparatus to blend the soil for about 1 minute.

11.2.1.1 Transfer all the dispersed slurry into the sedimentation cylinder. Use the wash/rinse bottle filled with test water as needed to make sure all of the slurry is transferred to the cylinder. Add test water to the sedimentation cylinder to bring the bottom of the meniscus of the slurry to the 1,000 mL ± 1 mm mark. Proceed to 11.3.

11.2.2 If using the tube type air jet device, transfer the slurry to the sedimentation cylinder. Use a wash/rinse bottle filled with test water to aid in the transfer and make sure all of the slurry has been transferred to the cylinder. Add additional test water as necessary to bring the volume to no more than 250 mL in the sedimentation cylinder.

11.2.2.1 Before placing the device into the cylinder, slowly allow air to flow until the gauge reads 7 kPa. This initial pressure is needed to prevent the slurry from entering the air jets when the device is inserted into the cylinder and to remove any water that has condensed in the lines. Then, slowly lower the device into the slurry. Make sure the rubber stopper is securely in place at the top of the cylinder to prevent the slurry from being ejected from the cylinder.

11.2.2.2 For clayey soils increase the pressure to 172 kPa and for sandy soils increase the pressure to 69 kPa. Once the