



Designation: F987–04 (Reapproved 2010) F987 – 04 (Reapproved 2017) An American National Standard

Standard Specification for Portable Intermediate Flush Deck Stanchion¹

This standard is issued under the fixed designation F987; the number immediately following the designation indicates the year of original adoption or, in the case of revision, the year of last revision. A number in parentheses indicates the year of last reapproval. A superscript epsilon (ϵ) indicates an editorial change since the last revision or reapproval.

1. Scope

1.1 This specification covers the design, construction, and installation of intermediate portable flush deck stanchions. Intermediate stanchion is defined as any stanchion that is not an end or corner stanchion.

1.2 Stanchions shall be used on interior and exterior decks, to provide temporary protection to minimize the danger of personnel falling overboard or to a lower level in the ship in areas where the installation of a fixed system would interfere with vessel operations.

1.3 Stanchions may be used with $\frac{3}{8}$ -in. (9.5-mm) galvanized close link chain or wire rope lifelines $\frac{9}{16}$ -in. (14-mm) top course, $\frac{7}{16}$ -in. (11-mm) lower courses.

1.4 This specification covers only the stanchions and does not cover requirements for the chain or wire rope lines to be supported by the stanchion.

1.5 The values stated in inch-pound units are to be regarded as standard. The values given in parentheses are mathematical conversions to SI units that are provided for information only and are not considered standard.

2. Referenced Documents

2.1 ASTM Standards:²

[A106/A106M Specification for Seamless Carbon Steel Pipe for High-Temperature Service](#)

[A123/A123M Specification for Zinc \(Hot-Dip Galvanized\) Coatings on Iron and Steel Products](#)

[A182/A182M Specification for Forged or Rolled Alloy and Stainless Steel Pipe Flanges, Forged Fittings, and Valves and Parts for High-Temperature Service](#)

[F783 Specification for Staple, Handgrab, Handle, and Stirrup Rung](#)

2.2 ANSI/ASME Standards:³

[ANSI B 16.11 Forged Steel Fittings, Socket-Welding, and Threaded](#)

[ANSI B 16.15 Cast Bronze Threaded Fittings](#)

2.3 ANSI/AWS Standard:³

[ANSI/AWS D 1.1 Structure Welding Code](#)

2.4 Code of Federal Regulations:⁴

[Title 46 Shipping, Parts 70 to 89, Subpart 72.40](#)

3. Classification

3.1 Portable flush deck stanchions shall be available in two types:

3.1.1 *Type I*—Two-course portable flush deck stanchions (see [Fig. 1](#)).

3.1.2 *Type II*—Three-course portable flush deck stanchions (see [Fig. 2](#)).

¹ This specification is under the jurisdiction of ASTM Committee F25 on Ships and Marine Technology and is the direct responsibility of Subcommittee F25.03 on Outfitting and Deck Machinery.

Current edition approved ~~May 1, 2010~~ Jan. 1, 2017. Published ~~June 2010~~ January 2017. Originally approved in 1986. Last previous edition approved in ~~2004~~ 2010 as ~~F987–04~~ F987 DOI: ~~10.1520/F0987-04R10-~~ 04 (2010). DOI: 10.1520/F0987-04R17.

² For referenced ASTM standards, visit the ASTM website, www.astm.org, or contact ASTM Customer Service at service@astm.org. For *Annual Book of ASTM Standards* volume information, refer to the standard's Document Summary page on the ASTM website.

³ Available from American National Standards Institute (ANSI), 25 W. 43rd St., 4th Floor, New York, NY 10036, <http://www.ansi.org>.

⁴ Available from U.S. Government Printing Office, Superintendent of Documents, 732 N. Capitol St., NW, ~~Mail Stop: SDE,~~ Washington, DC ~~20401~~ 20401-0001, <http://www.access.gpo.gov>.

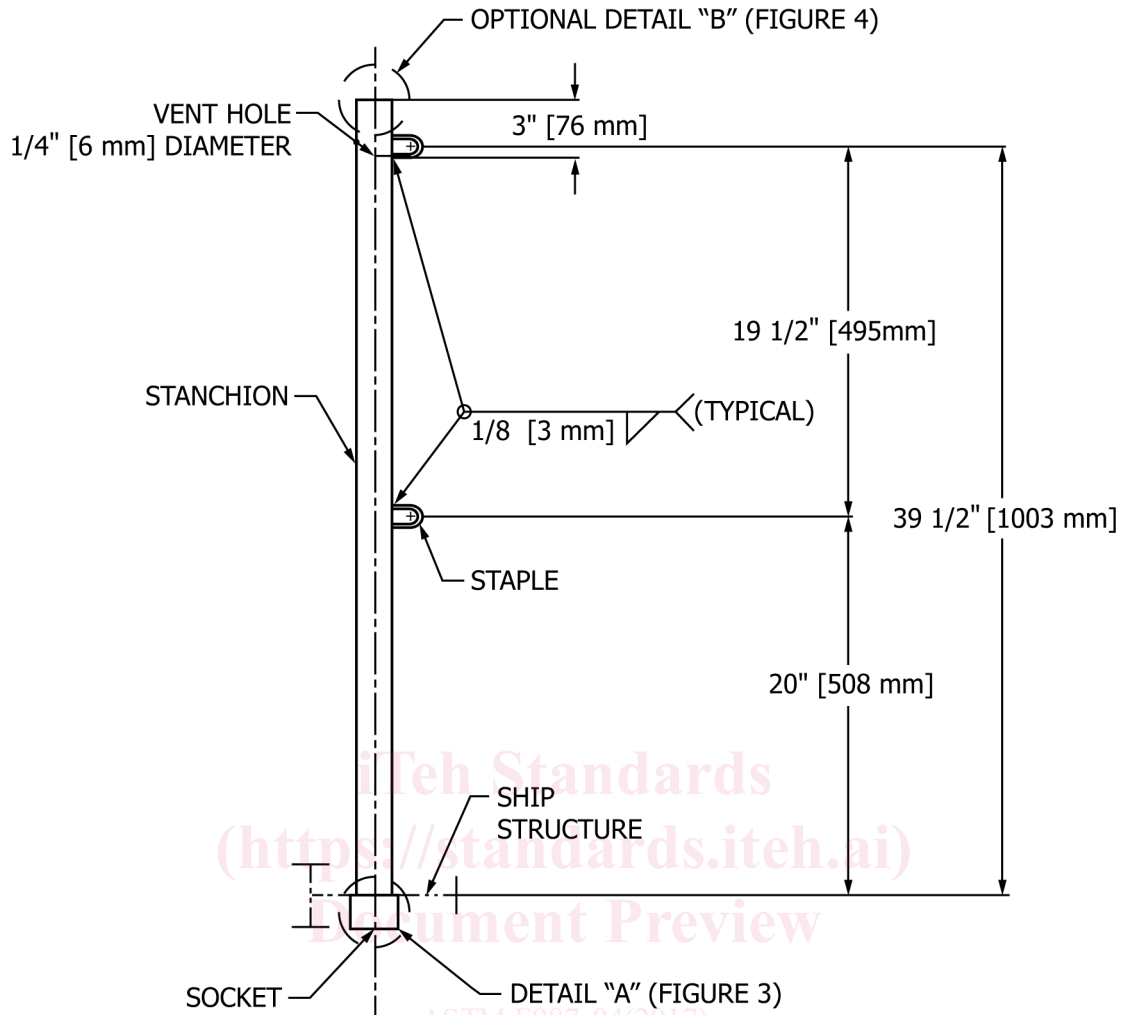

FIG. 1 Type I—Two Course Portable Flush Deck Stanchion

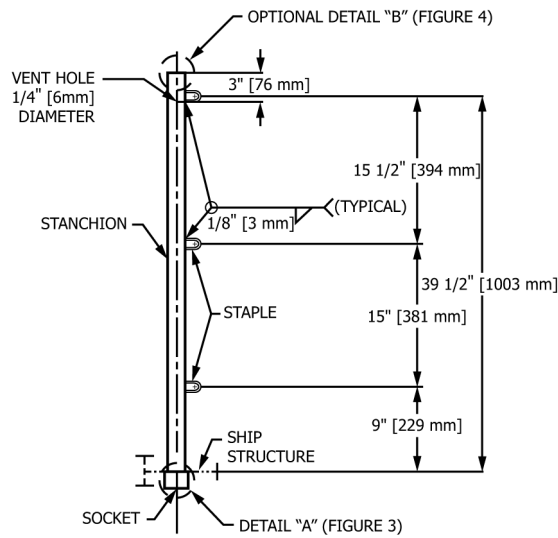

FIG. 2 Type II—Three Course Portable Flush Deck Stanchion

4. Ordering Information

4.1 Orders for portable flush deck stanchions under this specification shall include the following information:

4.1.1 ASTM designation and year of issue (that is, F987 - 04).