



Designation: D6256/D6256M – 16

# Standard Specification for Wood-Cleated Shipping Boxes with Skidded, Load-Bearing Bases<sup>1</sup>

This standard is issued under the fixed designation D6256/D6256M; the number immediately following the designation indicates the year of original adoption or, in the case of revision, the year of last revision. A number in parentheses indicates the year of last reapproval. A superscript epsilon ( $\epsilon$ ) indicates an editorial change since the last revision or reapproval.

*This standard has been approved for use by agencies of the U.S. Department of Defense.*

## 1. Scope

1.1 This specification covers the fabrication of new wood-cleated boxes with skidded, load-bearing bases. Boxes covered by this specification are designed for nonregulated domestic and overseas shipment of loads less than 2500 lb [1134 kg] and not greater than 16 ft [4877 mm] in length (see 9.1). Regulated commodities shipments may require better boxes than those specified herein (see 9.2).

1.2 The performance of wood-cleated boxes with skidded, load-bearing bases is dependent on their fabricated components; therefore, a variety of types, styles, and classes reflecting varied performance are specified. This specification, however, does not cover box performance under all atmosphere, handling, shipping and storage conditions.

1.3 If the use of other construction methods or techniques are acceptable and permitted (see 5.1.18), the resulting packaging systems shall be of equal or better performance than would result from the use of these specified materials and procedures. The appropriate distribution cycle specified in Practice D4169 can be used to develop comparative procedures and criteria.

1.4 The values stated in either inch-pound units or SI units are to be regarded separately as standard. Within the text, the SI units are shown in brackets. The values stated in each system are not exact equivalents; therefore, each system must be used independently of the other. Combining values from the two systems may result in nonconformance with the standard. See IEEE/ASTM SI 10 for conversion of units.

1.5 *This standard does not purport to address all of the safety concerns, if any, associated with its use. It is the responsibility of the user of the standard to establish appropriate safety and health practices and determine the applicability of regulatory limitations prior to use.*

<sup>1</sup> This specification is under the jurisdiction of ASTM Committee D10 on Packaging and is the direct responsibility of Subcommittee D10.12 on Shipping Containers, Crates, Pallets, Skids and Related Structures.

Current edition approved Dec. 1, 2016. Published January 2017. Originally approved in 1998. Last previous edition approved in 2010 as D6256/D6256M – 10. DOI: 10.1520/D6256\_D6256M-16.

## 2. Referenced Documents

### 2.1 ASTM Standards:<sup>2</sup>

D996 Terminology of Packaging and Distribution Environments

D3951 Practice for Commercial Packaging

D3953 Specification for Strapping, Flat Steel and Seals

D4169 Practice for Performance Testing of Shipping Containers and Systems

D4675 Guide for Selection and Use of Flat Strapping Materials<sup>1</sup>

D4727/D4727M Specification for Corrugated and Solid Fiberboard Sheet Stock (Container Grade) and Cut Shapes

D6039/D6039M Specification for Open and Covered Wood Crates

D6199 Practice for Quality of Wood Members of Containers and Pallets

D6251/D6251M Specification for Wood-Cleated Panelboard Shipping Boxes

D6253 Practice for Treatment and/or Marking of Wood Packaging Materials

F1667 Specification for Driven Fasteners: Nails, Spikes, and Staples

IEEE/ASTM SI 10 Standard for Use of the International System of Units (SI): The Modern Metric System

### 2.2 American Wood Protection Association (AWPA) Standard:<sup>3</sup>

P36 Standard for Copper Naphthenate (CuN)

P37 Standard for Oxine Copper (Copper 8-Quinolinolate) (Cu8)

### 2.3 Code of Federal Regulations:<sup>4</sup>

CFR Parts 107–180 Title 49, Hazardous Materials Regulations

<sup>2</sup> For referenced ASTM standards, visit the ASTM website, www.astm.org, or contact ASTM Customer Service at service@astm.org. For Annual Book of ASTM Standards volume information, refer to the standard's Document Summary page on the ASTM website.

<sup>3</sup> Available from American Wood Protection Association (AWPA), P.O. Box 361784, Birmingham, AL 35236-1784, http://www.awpa.com.

<sup>4</sup> Available from U.S. Government Printing Office Superintendent of Documents, 732 N. Capitol St., NW, Mail Stop: SDE, Washington, DC 20401, http://www.access.gpo.gov.

2.4 *National Institute of Standards and Technology (NIST) Standards:*

- PS1 Voluntary Product Standard, Structural Plywood<sup>5</sup>
- PS2 Performance Standard for Wood-Based Structural-Use Panels<sup>6</sup>
- PS20 American Softwood Lumber Standard<sup>6</sup>

2.5 *American Society of Mechanical Engineers (ASME) Standards:*<sup>7</sup>

- B18.2.1 Square and Hex Bolts and Screws—Inch Series
- B18.2.2 Square and Hex Nuts (Inch Series)
- B18.2.3.8M Metric Hex Lag Screws
- B18.2.4.2M Metric Hex Nuts, Style 2
- B18.5 Round Head Bolts (Inch Series)
- B18.5.2.2M Metric Round Head Square Neck Bolts
- B18.22M Metric Plain Washers
- B18.22.1 Plain Washers

2.6 *Hardwood Plywood and Veneer Association (HPVA) Standard:*<sup>8</sup>

- ANSI/HPVA HP-1-2004 American National Standard for Hardwood and Decorative Plywood

2.7 *National Motor Freight Traffic Association (NMFTA) Standard:*<sup>9</sup>

- National Motor Freight Classification

2.8 *National Hardwood Lumber Association (NHLA) Standard:*<sup>10</sup>

- NHLA Rules for the Measurement and Inspection of Hardwood and Cypress

2.9 *International Standard:*<sup>11</sup>

- ISPM Publication No. 15 Regulation of Wood Packaging Material in International Trade

2.10 *Federal Standard:*<sup>12</sup>

- MIL-DTL-2427H Detail Specification Box, Ammunition Packing: Wood, Nailed

### 3. Terminology

3.1 *Definitions*—General definitions for packaging and distribution environments are found in Terminology D996.

### 4. Classification

4.1 *Type:*

- 4.1.1 *Type I*—Plywood base (see Fig. 1).
- 4.1.2 *Type II*—Lumber base (see Fig. 1).

<sup>5</sup> Available from The Engineered Wood Association (APA), 7011 S. 19th St., Tacoma, WA 98466-5333, <http://www.apawood.org>.

<sup>6</sup> Available from American Lumber Standards Committee, Inc. (ALSC), P.O. Box 210, Germantown, MD 20875-0210, <http://www.alsc.org>.

<sup>7</sup> Available from American Society of Mechanical Engineers (ASME), ASME International Headquarters, Two Park Ave., New York, NY 10016-5990, <http://www.asme.org>, American National Standard Institute (ANSI) adopted.

<sup>8</sup> Available from Hardwood Plywood and Veneer Association (HPVA), P.O. Box 2789, Reston, VA 22090-0789, <http://www.hpva.org>, American National Standards Institute (ANSI) adopted.

<sup>9</sup> Available from National Motor Freight Traffic Association (NMFTA), 1001 N. Fairfax St., Alexandria, VA 22314, <http://www.nmfta.org>.

<sup>10</sup> Available from the Uniform Classification Committee, Tariff Publishing Officer, 151 Ellis St. N.E., Suite 200, Atlanta, GA 30335.

<sup>11</sup> Available from International Plant Protection Convention, <http://www.ippc.int>.

<sup>12</sup> Available from U.S. Government Printing Office Superintendent of Documents, 732 N. Capitol St., NW, Mail Stop: SDE, Washington, DC 20401, <http://www.access.gpo.gov>.

4.2 *Class:*

- 4.2.1 *Class 1*—Domestic.
- 4.2.2 *Class 2*—Overseas.

4.3 *Style:*

- 4.3.1 *Style A*—Regular cleating arrangement (see Fig. 2).
- 4.3.2 *Style B*—Lock corner cleating arrangement (see Fig. 2).

4.4 *Treatment:*

- 4.4.1 *Treatment A*—Without preservative treatment.
- 4.4.2 *Treatment B*—With preservative treatment.

### 5. Ordering Information

5.1 Purchasers should select the preferred permitted options and include the following information in procurement documents:

- 5.1.1 Specification title, number, and date.
- 5.1.2 Box type, style, and class required (see Section 4).
- 5.1.3 Type of base flooring (see 4.1).
- 5.1.4 If plywood is treated (see 4.4 and 6.1.2).
- 5.1.5 If beveling of skids is required (see 6.2).
- 5.1.6 Contents weight (see Table 1).
- 5.1.7 If rubbing strips are required (see 6.2.4).
- 5.1.8 Type of superstructure (see 6.2.5).
- 5.1.9 Joist requirement (see 6.2.5.2).
- 5.1.10 Box inside dimensions specified in inches [millimetres] to the nearest ½ in. [13 mm] in order of length by width by height (see 7.1).
- 5.1.11 Whether boxes are to be shipped assembled or knocked-down (see 7.4.2 and 8.1).
- 5.1.12 When corner straps are required (see 7.4.2.4).
- 5.1.13 Whether ventilation holes or slots are required (see 7.5).
- 5.1.14 Whether special packing is required (see 8.3).
- 5.1.15 Whether special marking is required (see 8.3).
- 5.1.16 Load condition (see Figs. 3 and 4).
- 5.1.17 Whether a regulated materials box is required (see 9.2).

5.1.17.1 Physical characteristics of load, including contents dimensions, weight, and density.

5.1.17.2 Whether a test report is required.

5.1.18 Whether other construction methods or techniques are acceptable and permitted (see 1.3).

5.1.18.1 Whether proof that other construction methods or techniques are acceptable (see 1.3) is required.

5.1.19 When ISPM Publication No. 15 compliance is required (see 7.8).

### 6. Materials and Manufacture

6.1 *Materials*—Materials shall be as specified herein. Materials not specified shall be selected by the contractor or box builder and shall be subject to all provisions of this specification. Materials shall be free of defects, which adversely affect performance or serviceability of the finished box. It is encouraged that recycled material be used when practical. All recovered, recycled, or virgin materials used in box manufacturing shall meet the requirements of this specification and the referenced documents. In addition, materials shall not affect or be affected by the product being packed.

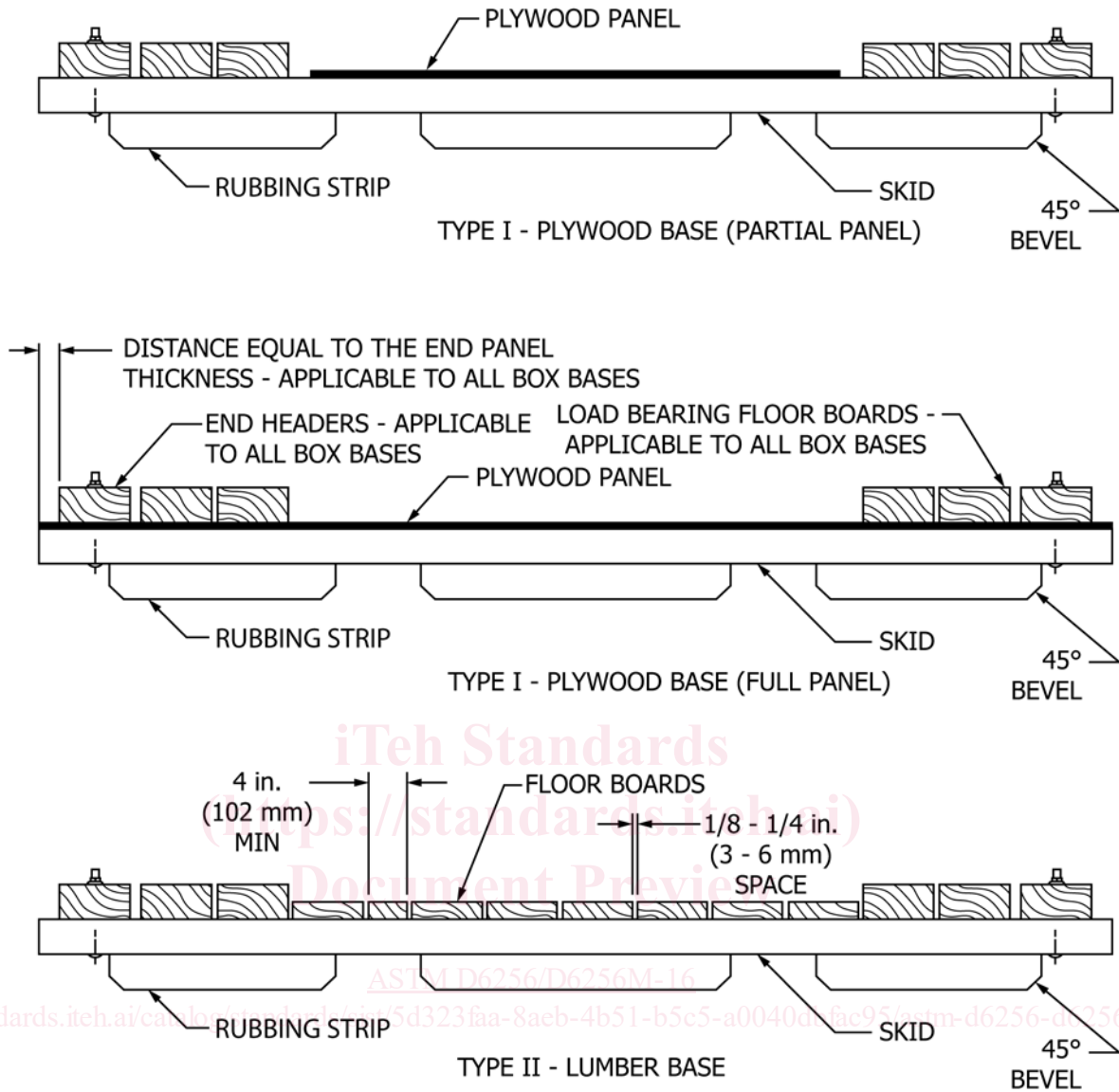

FIG. 1 Base Types

6.1.1 *Lumber*—Lumber components shall conform to Practice D6199, PS20, or the NHLA Rules. Lumber components shall be the industries' commonly accepted practice for nominal sizes and wood species and shall conform to commercial practice standards in accordance with Practice D6199, unless otherwise specified. Lumber components shall have a target thickness and width uniform in dimension and 50 % of components shall meet or exceed target dimensions at the time of component manufacture. Lumber for superstructure components shall conform to the requirements for cleated panel boxes, Specification D6251/D6251M, and lumber for base components to those for crates, Specification D6039/D6039M.

6.1.2 *Plywood*—Plywood shall be performance-rated paneling manufactured in accordance with PS1, PS2, or ANSI/HPVA HP-1-2004. All panels shall be bonded with moisture resistant adhesive and be identified as either Exposure 1 or Exterior. Plywood shall have no defects (knot holes, worm holes, and so forth) extending through the panel. Water-

repellent wood preservatives conforming to AWPA Standards P36 or P37, or a commercial equivalent, shall be used when treatment is specified (see 4.4 and 5.1.4).

6.1.3 *Fiberboard*—Unless otherwise specified, fiberboard shall conform to Specification D4727/D4727M. Class 1 boxes shall be fabricated from Type SF, Class – Domestic, Grade 500 or 600. Class 2 boxes shall be fabricated from Type SF, Class – Weather-Resistant, Grade V2s, V3s, or V4s.

6.1.4 *Fasteners*—Fasteners are classified as driven nails, lag bolts, and bolts. shall be steel and conform to Specification F1667, and other industry standards.

6.1.4.1 *Nails*—Nails shall be in accordance with Specification F1667 and other industry standards. Nails are classified as plain-shank, helically threaded, annularly threaded, fluted, or twisted square wire.

6.1.4.2 *Lag Bolts, Bolts, Nuts, and Washers*—Lag bolts, bolts, screws, nuts, and washers shall be in accordance with ASME B18.2.1 (B18.2.3.8M), ASME B18.5 (B18.5.2.2M),

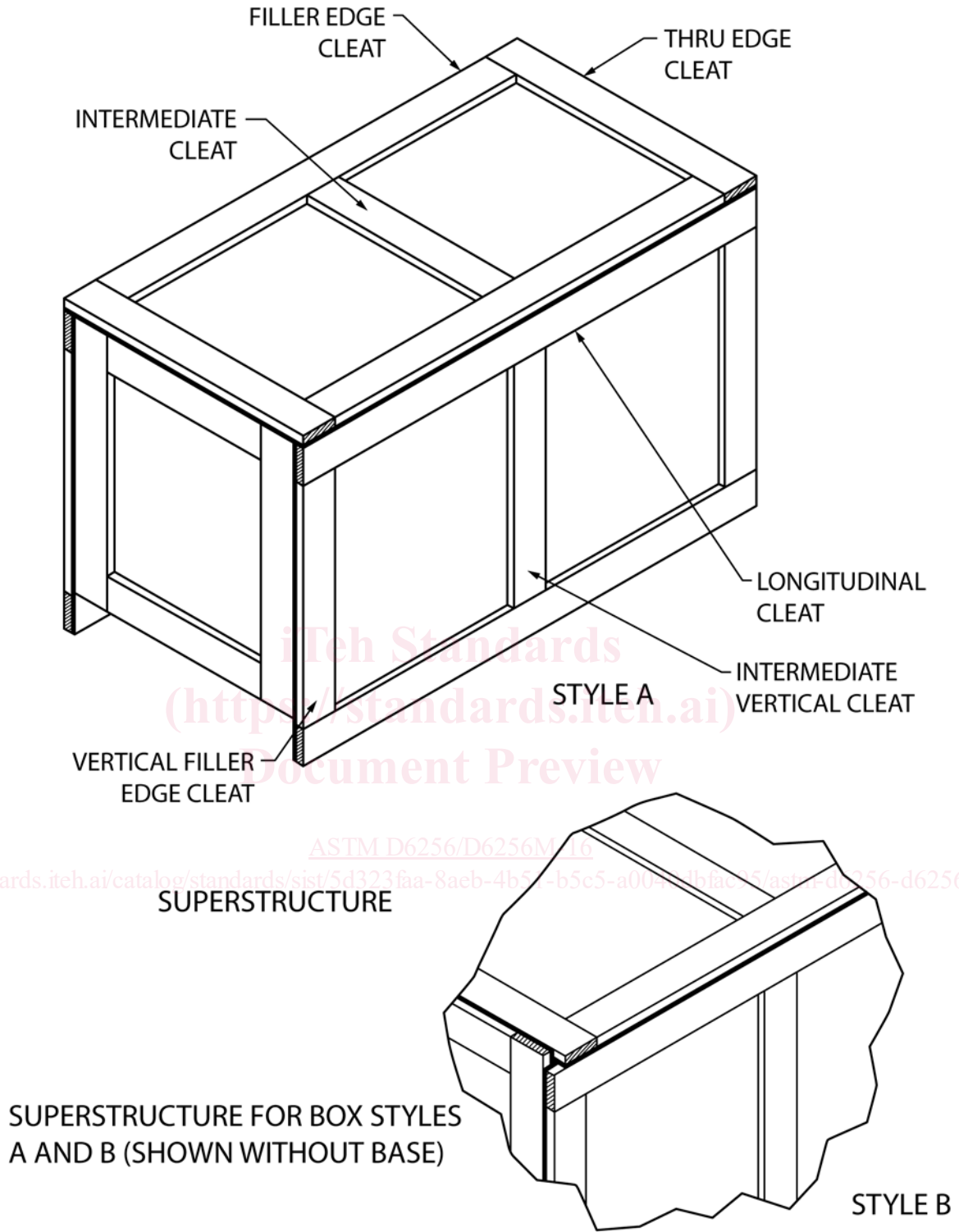

FIG. 2 Box Styles

ASME B18.2.2 (B18.2.4.2M), ASME B18.22.1 (B18.22M), and other industry standards.

6.1.4.3 *Metallic Strips*—Strapping used to reinforce the box shall conform to Specification D3953, Guide D4675, and other industry standards. Strapping finish shall be as specified herein.

6.1.5 *Water-Repellent Wood Preservative*—Water-repellent wood preservative shall be a solution containing either copper

naphthenate conforming with Practice D6253, MIL-DTL-2427H, and AWPA Standard P36 with a minimum concentration of 2.0 % copper metal, oxine copper (formerly referred to as copper-8-quinolinolate) conforming with Practice D6253, MIL-DTL-2427H, and AWPA Standard P37 with a minimum concentration of 1.8 % copper metal, or 3 % zinc naphthenate conforming to Practice D6253 and MIL-DTL-2427H.

**TABLE 1 Skid Nominal Sizes<sup>A</sup> and Maximum Lengths**

Contents Weight lb [kg]	Load <sup>B</sup> Condition	Nominal Sizes <sup>A</sup> in. [mm]					
		2 by 4 [38 by 89]	2 by 6 [38 by 140]	2 by 8 [38 by 184]	4 by 4 [89 by 89]	4 by 6 [89 by 140]	6 by 6 [140 by 140]
		Skid Max Length ft [mm]					
0–100 [0–45]	A	16 [4877]	...	...	...	...	...
	B	16 [4877]	...	...	...	...	...
	C	16 [4877]	...	...	...	...	...
	D	16 [4877]	...	...	...	...	...
	E	16 [4877]	...	...	...	...	...
101–200 [45.8–90.7]	A	16 [4877]	...	...	...	...	...
	B	16 [4877]	...	...	...	...	...
	C	16 [4877]	...	...	...	...	...
	D	16 [4877]	...	...	...	...	...
	E	16 [4877]	...	...	...	...	...
201–400 [91.2–181.4]	A	11 [3353]	15 [4572]	16 [4877]	...	...	...
	B	13 [3962]	16 [4877]	...	...	...	...
	C	8 [2438]	12 [3658]	16 [4877]	...	...	...
	D	10 [3048]	15 [4572]	16 [4877]	...	...	...
	E	13 [3962]	16 [4877]	...	...	...	...
401–600 [181.9–272.2]	A	8 [2438]	11 [3353]	14 [4267]	16 [4877]	...	...
	B	9 [2743]	14 [4267]	16 [4877]	...	...	...
	C	5 [1524]	8 [2438]	11 [3353]	16 [4877]	...	...
	D	7 [2134]	10 [3048]	14 [4267]	16 [4877]	...	...
	E	9 [2743]	14 [4267]	16 [4877]	...	...	...
601–800 [272.6–363]	A	7 [2134]	9 [2743]	11 [3353]	16 [4877]	...	...
	B	7 [2134]	10 [3048]	14 [4267]	16 [4877]	...	...
	C	4 [1219]	6 [1829]	8 [2438]	16 [4877]	...	...
	D	5 [1524]	8 [2438]	10 [3048]	16 [4877]	...	...
	E	7 [2134]	10 [3048]	14 [4267]	16 [4877]	...	...
801–1000 [363.3–453.6]	A	6 [1829]	8 [2438]	10 [3048]	16 [4877]	...	...
	B	5 [1524]	8 [2438]	11 [3353]	16 [4877]	...	...
	C	3 [914]	5 [1524]	7 [2134]	16 [4877]	...	...
	D	4 [1219]	6 [1829]	8 [2438]	16 [4877]	...	...
	E	5 [1524]	8 [2438]	11 [3353]	16 [4877]	...	...
1001–1200 [454–544.3]	A	6 [1829]	7 [2134]	8 [2438]	16 [4877]	...	...
	B	4 [1219]	7 [2134]	9 [2743]	16 [4877]	...	...
	C	3 [914]	4 [1219]	5 [1524]	13 [3962]	16 [4877]	...



D6256/D6256M – 16

TABLE 1 Continued

Contents Weight lb [kg]	Load <sup>B</sup> Condition	Nominal Sizes <sup>A</sup> in. [mm]					
		2 by 4 [38 by 89]	2 by 6 [38 by 140]	2 by 8 [38 by 184]	4 by 4 [89 by 89]	4 by 6 [89 by 140]	6 by 6 [140 by 140]
		Skid Max Length ft [mm]					
	D	3 [914]	5 [1524]	7 [2134]	16 [4877]	...	...
	E	4 [1219]	7 [2134]	9 [2743]	16 [4877]	...	...
1201–1400 [544.8–635]	A	5 [1524]	7 [2134]	8 [2438]	14 [4267]	16 [4877]	...
	B	5 [1524]	6 [1829]	8 [2438]	16 [4877]	...	...
	C	0 [0]	4 [1219]	5 [1524]	11 [3353]	16 [4877]	...
	D	3 [914]	4 [1219]	6 [1829]	14 [4267]	16 [4877]	...
	E	5 [1524]	6 [1829]	8 [2438]	16 [4877]	...	...
1401–1600 [635.5–725.7]	A	5 [1524]	6 [1829]	7 [2134]	13 [3962]	16 [4877]	...
	B	3 [914]	5 [1524]	7 [2134]	16 [4877]	...	...
	C	0 [0]	3 [914]	4 [1219]	18 [5486]	15 [4572]	16 [4877]
	D	3 [914]	4 [1219]	5 [1524]	12 [3658]	16 [4877]	...
	E	3 [914]	5 [1524]	7 [2134]	16 [4877]	...	...
1601–1800 [726.2–816.5]	A	5 [1524]	6 [1829]	7 [2134]	12 [3658]	16 [4877]	...
	B	3 [914]	5 [1524]	6 [1829]	15 [4572]	16 [4877]	...
	C	0 [0]	3 [914]	4 [1219]	9 [2743]	14 [4267]	16 [4877]
	D	0 [0]	3 [914]	4 [1219]	11 [3353]	16 [4877]	...
	E	3 [914]	5 [1524]	6 [1829]	15 [4572]	16 [4877]	...
1801–2000 [816.9–907.2]	A	4 [1219]	5 [1524]	6 [1829]	11 [3353]	15 [4572]	16 [4877]
	B	3 [914]	4 [1219]	5 [1524]	13 [3962]	16 [4877]	...
	C	0 [0]	0 [0]	3 [914]	8 [2438]	12 [3658]	16 [4877]
	D	0 [0]	3 [914]	4 [1219]	10 [3048]	15 [4572]	16 [4877]
	E	3 [914]	4 [1219]	5 [1524]	13 [3962]	16 [4877]	...
2001–2200 [907.6–997.9]	A	4 [1219]	5 [1524]	6 [1829]	10 [3048]	14 [4267]	16 [4877]
	B	0 [0]	4 [1219]	5 [1524]	12 [3658]	16 [4877]	...
	C	0 [0]	0 [0]	3 [914]	7 [2134]	11 [3353]	16 [4877]
	D	0 [0]	3 [914]	4 [1219]	9 [2743]	14 [4267]	16 [4877]
	E	0 [0]	4 [1219]	5 [1524]	12 [3658]	16 [4877]	...
2201–2400 [998.4–1088.6]	A	4 [1219]	5 [1524]	6 [1829]	10 [3048]	13 [3962]	16 [4877]
	B	0 [0]	3 [914]	4 [1219]	11 [3353]	16 [4877]	16 [4877]
	C	0 [0]	0 [0]	3 [914]	7 [2134]	10 [3048]	16 [4877]
	D	0 [0]	0 [0]	3 [914]	8 [2438]	13 [3962]	16 [4877]
	E	0 [0]	3 [914]	4 [1219]	11 [3353]	16 [4877]	...
2401–2500	A	4	5	6	9	13	16