



Standard Specification for Mechanical Seals for Shipboard Pump Applications¹

This standard is issued under the fixed designation F 1511; the number immediately following the designation indicates the year of original adoption or, in the case of revision, the year of last revision. A number in parentheses indicates the year of last reapproval. A superscript epsilon (ϵ) indicates an editorial change since the last revision or reapproval.

1. Scope

1.1 This specification covers mechanical end-face seals for centrifugal and positive displacement pumps for shipboard use.

1.2 The following types of seals are not included in this specification: lip seals, oil seals, circumferential seals, labyrinth seals or gas seals.

1.3 The values stated in inch-pound units are to be regarded as the standard. The SI units given in parentheses are for information only. A companion hard metric standard is in the process of preparation.

1.4 Special requirements for U.S. Navy Shipboard Pump Applications are included in Supplement S1.

2. Referenced Documents

2.1 ASTM Standards:

A 108 Specification for Steel Bars, Carbon, Cold-Finished, Standard Quality²

A 182/A182M Specification for Forged or Rolled Alloy-Steel Pipe Flanges, Forged Fittings, and Valves and Parts for High-Temperature Service³

A 240/A 240M Specification for Heat-Resisting Chromium and Chromium-Nickel Stainless Steel Plate, Sheet, and Strip for Pressure Vessels⁴

A 276 Specification for Stainless Steel Bars and Shapes⁴

A 313/A 313M Specification for Stainless Steel Spring Wire⁴

A 351/A351M Specification for Castings, Austenitic, Austenitic-Ferritic (Duplex), for Pressure-Containing Parts⁵

A 436 Specification for Austenitic Gray Iron Castings⁵

A 494/A494M Specification for Castings, Nickel and Nickel Alloy⁵

A 564/A564M Specification for Hot-Rolled and Cold-Finished Age-Hardening Stainless Steel Bars and Shapes⁴

A 579 Specification for Superstrength Alloy Steel Forgings²

A 693 Specification for Precipitation-Hardening Stainless

and Heat-Resisting Steel Plate, Sheet, and Strip⁴

A 705/A705M Specification for Age-Hardening Stainless and Heat-Resisting Steel Forgings⁴

A 744/A744M Specification for Castings, Iron-Chromium-Nickel, Corrosion Resistant, for Severe Service⁵

B 62 Specification for Composition Bronze or Ounce Metal Castings⁶

B 127 Specification for Nickel-Copper Alloy (UNS N04400) Plate, Sheet, and Strip⁷

B 164 Specification for Nickel-Copper Alloy Rod, Bar, and Wire⁷

B 166 Specification for Nickel-Chromium-Iron Alloys (UNS N06600, N06601, N06690, N06025, and N06045) and Nickel-Chromium-Cobalt-Molybdenum Alloy (UNS N06617) Rod, Bar, and Wire⁷

B 168 Specification for Nickel-Chromium-Iron Alloys (UNS N06600, N06601, and N06690) and Nickel-Chromium-Cobalt-Molybdenum Alloy (UNS N06617) Plate, Sheet, and Strip⁷

B 271 Specification for Copper-Base Alloy Centrifugal Castings⁶

B 333 Specification for Nickel-Molybdenum Alloy Plate, Sheet, and Strip⁷

B 335 Specification for Nickel-Molybdenum Alloy Rod⁷

B 338 Specification for Seamless and Welded Titanium and Titanium Tubes for Condensers and Heat Exchangers⁷

B 348 Specification for Titanium and Titanium Alloy Bars and Billets⁷

B 367 Specification for Titanium and Titanium Alloy Castings⁷

B 443 Specification for Nickel-Chromium-Molybdenum-Columbium Alloy (UNS N06625) Plate, Sheet, and Strip⁷

B 446 Specification for Nickel-Chromium-Molybdenum-Columbium Alloy (UNS N06625) Rod and Bar⁷

B 472 Specification for Nickel Alloy UNS N08020, UNS N08026, UNS N08024, UNS N08926, and UNS N08367 and UNS R20033 Nickel Alloy Billets and Bars for Reforging⁷

B 473 Specification for UNS N08020, UNS N08026, and UNS N08024 Nickel Alloy Bar and Wire⁷

B 505 Specification for Copper-Base Alloy Continuous Castings⁶

¹ This specification is under the jurisdiction of ASTM Committee F-25 on Ships and Marine Technology and is the direct responsibility of Subcommittee F25.11 on Machinery.

Current edition approved Nov. 10, 1998. Published May 1999. Originally published as F 1511 – 94. Last previous edition F 1511 – 96.

² *Annual Book of ASTM Standards*, Vol 01.05.

³ *Annual Book of ASTM Standards*, Vol 01.01.

⁴ *Annual Book of ASTM Standards*, Vol 01.03.

⁵ *Annual Book of ASTM Standards*, Vol 01.02.

⁶ *Annual Book of ASTM Standards*, Vol 02.01.

⁷ *Annual Book of ASTM Standards*, Vol 02.04.

B 574 Specification for Low-Carbon Nickel-Molybdenum-Chromium and Low-Carbon Nickel-Chromium-Molybdenum Alloy Rod⁷

B 575 Specification for Low-Carbon Nickel-Molybdenum-Chromium and Low-Carbon Nickel-Chromium-Molybdenum Alloy Plate, Sheet, and Strip⁷

B 584 Specification for Copper Alloy Sand Castings for General Applications⁶

B 637 Specification for Precipitation-Hardening Nickel Alloy Bars, Forgings, and Forging Stock for High-Temperature Service⁷

B 670 Specification for Precipitation-Hardening Nickel Alloy (UNS N07718) Plate, Sheet, and Strip for High-Temperature Service⁷

D 1141 Specification for Substitute Ocean Water⁸

D 1418 Practice for Rubber and Rubber Latex Nomenclature⁹

D 3294 Specification for PTFE Resin Molded Basic Shapes¹⁰

D 3951 Practice for Commercial Packaging¹¹

2.2 ASQC Standards:¹²

Z1.4 American Society of Quality Control, Quality Conformance Inspection

2.3 ANSI Standards:¹³

Y14.1 Drawing Sheet Size and Format

Y14.2 Line Convention and Lettering

Y14.3 Multi and Sectional View Drawings

Y14.5 Dimensioning and Tolerancing for Engineering Drawings

Y14.6 Screw Thread Representation

Y14.26.3 Computer-Aided Preparation of Production Definition Data, Terms and Definitions

2.4 Military Standards:¹⁴

MIL-S-901 Shock Tests, H.I. (High Impact); Shipboard Machinery, Equipment & Systems, Requirements for

MIL-P-16789 Packaging of Pumps, Including Prime Movers and Associated Repair Parts

MIL-R-83248 Rubber Fluorocarbon Elastomer, High Temperature, Fluid, and Compression Set Resistant

2.5 ISO Standard:¹³

ISO 9001 Quality Systems—Model for Quality Assurance in Design/Development, Production, Installation, and Service

2.6 Other Document:¹⁴

Metals and Alloys— Unified Numbering System-DS-56f

3. Terminology

3.1 Refer to Annex A1 for terminology relating to mechanical seals.

4. Classification of Seal Arrangements

4.1 For this specification mechanical seals shall be classified by type, grade, and class. The categories are divided by application arrangement in the equipment in which it is installed.

4.1.1 Type A Inside Single Mounted Seals

4.1.2 Type B Outside Single Mounted Seals

4.1.3 Type C Double Seals

4.1.4 Type D Tandem Seals

4.1.5 Type E Special Arrangements/Applications Vacuum or Gas Seal

4.1.6 Grade 1 Basic End Face Seal

4.1.7 Grade 2 Cartridge Seal

4.1.8 Grade 3 Split Seal

4.1.9 Class 0 Nonsplit Seal Assembly

4.1.10 Class 1 Partial Split Seal Assembly, Solid Gland

4.1.11 Class 2 Partial Split Seal Assembly, Split Gland

4.1.12 Class 3 Fully Split Seal Assembly, Solid Gland

4.1.13 Class 4 Fully Split Seal Assembly, Split Gland

4.2 Figs. 1-6 give general orientation information for various types of seals. The specific design of seal shown is not limited to that particular application.

5. Ordering Information

5.1 The purchaser shall provide the manufacturer with all of the pertinent application data shown in Figs. 7-9. If special operating conditions exist that are not shown in the checklist, they shall also be described.

6. Material

6.1 Mechanical seals shall be constructed of materials selected from Tables 1-3 after reviewing temperature, pressure/velocity (PV), and corrosion resistance requirements for all parts for each application.

6.2 Metal Components:

6.2.1 Mechanical seal metal parts in contact with the pumped liquid shall be compatible with their environment.

6.2.2 Table 1 identifies metal component compatibility.

6.2.3 Material specifications:

⁸ Annual Book of ASTM Standards, Vol 11.02.

⁹ Annual Book of ASTM Standards, Vol 09.01.

¹⁰ Annual Book of ASTM Standards, Vol 08.02.

¹¹ Annual Book of ASTM Standards, Vol 15.09.

¹² Available from American Society of Quality Control, 230 W. Wells St., Milwaukee, WI 53200.

¹³ Available from American National Standards Institute, 11 W. 42nd St., 13th Floor, New York, NY 10036.

¹⁴ Available from Standardization Documents Order Desk, Bldg. 4, Section D, 700 Robbins Ave., Philadelphia, PA 19111-5094, Attn: NPODS.

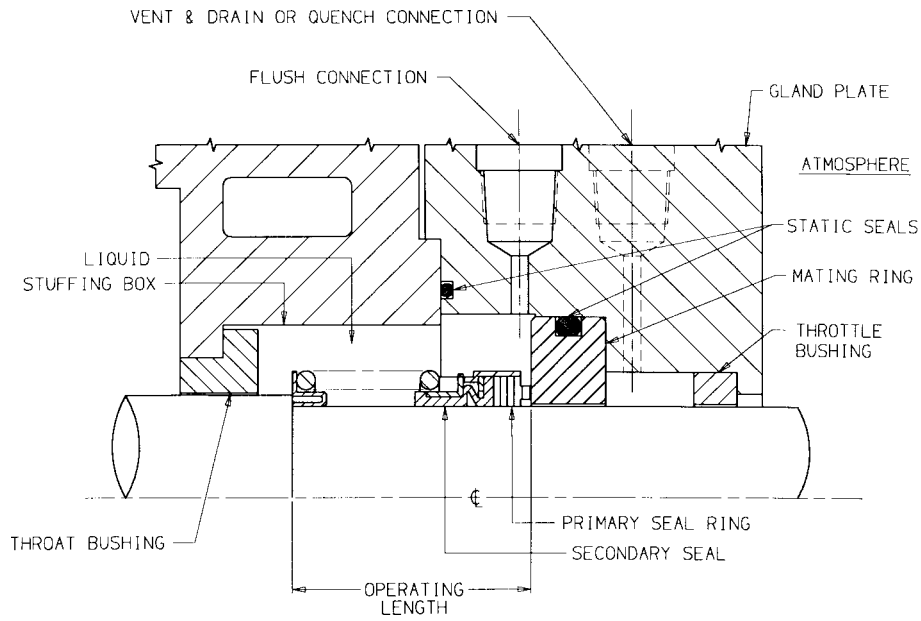

FIG. 1 Single Seal—Inside Mounted Classification Type A Grade 1

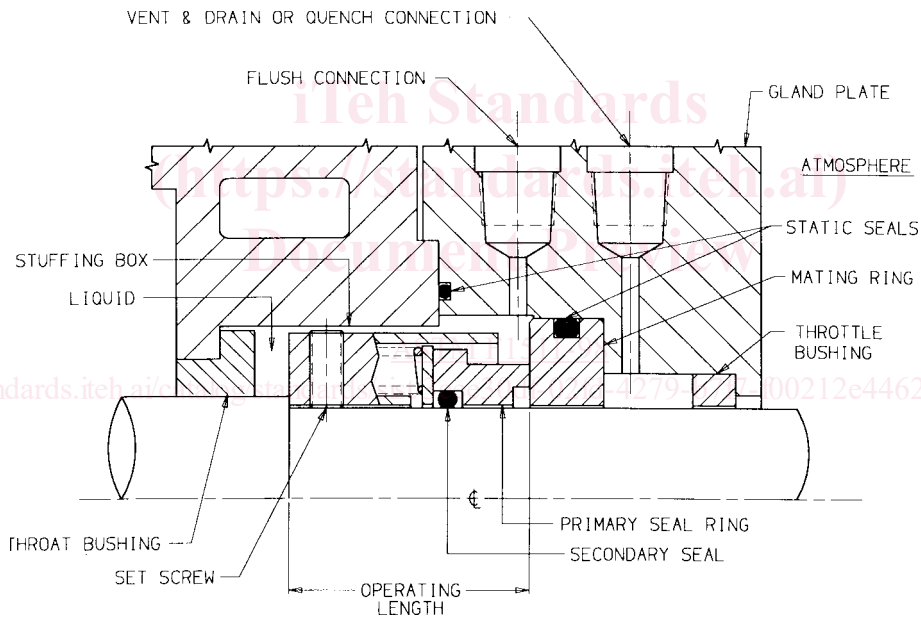

FIG. 2 Single Seal—Inside Mounted Classification Type A Grade 1

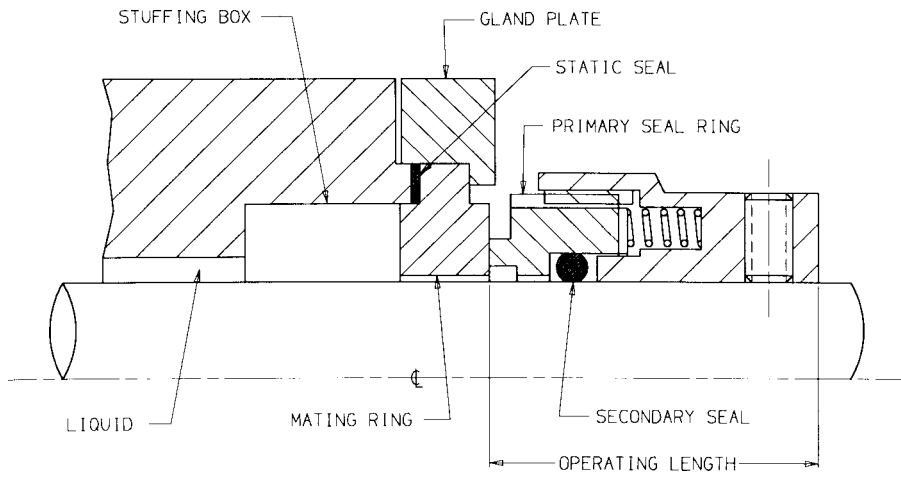

FIG. 3 Single Seal—Outside Mounted Classification Type B Grade 1

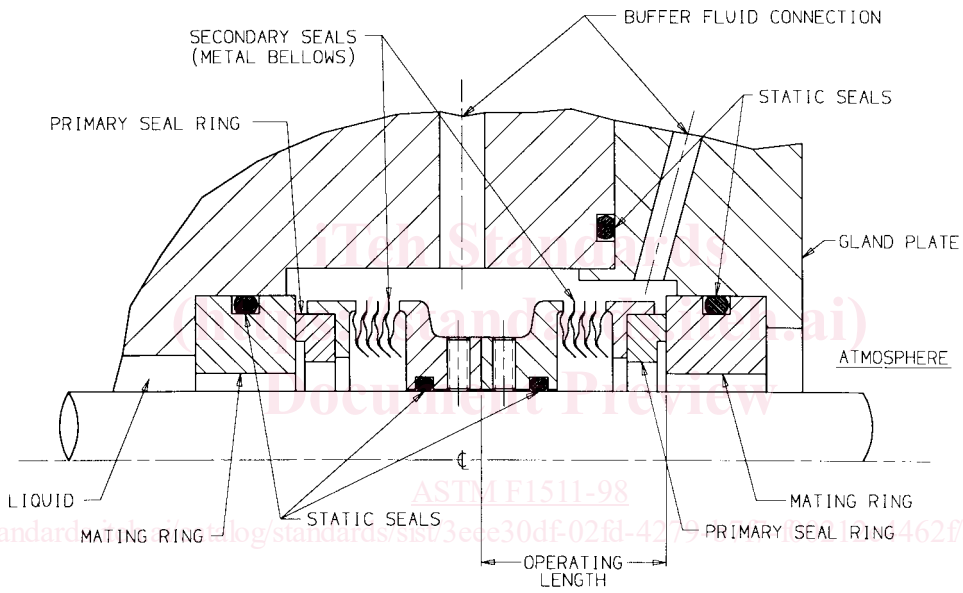

FIG. 4 Double Seals—Back to Back Classification Type C Grade 1

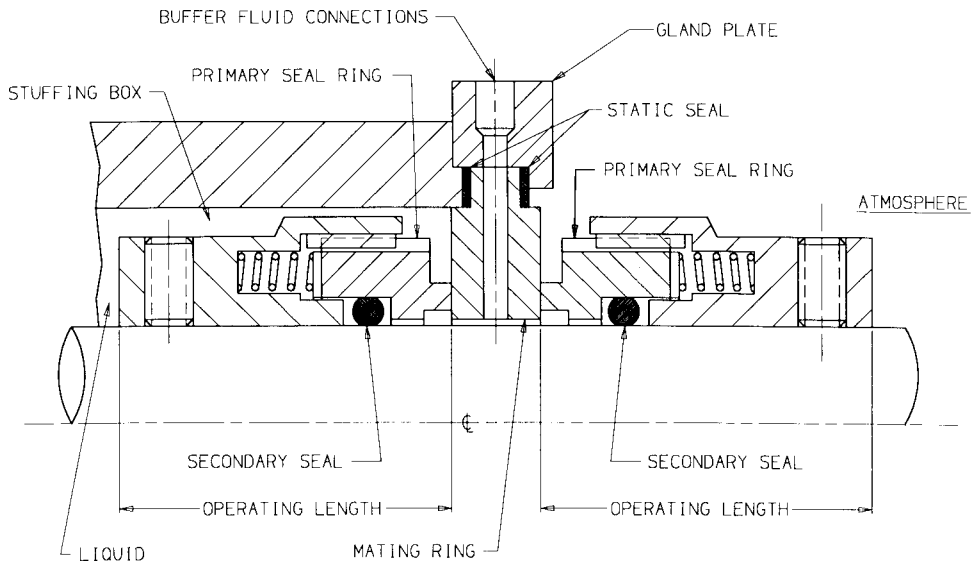

FIG. 5 Double Seals—Face to Face Classification Type C Grade 1

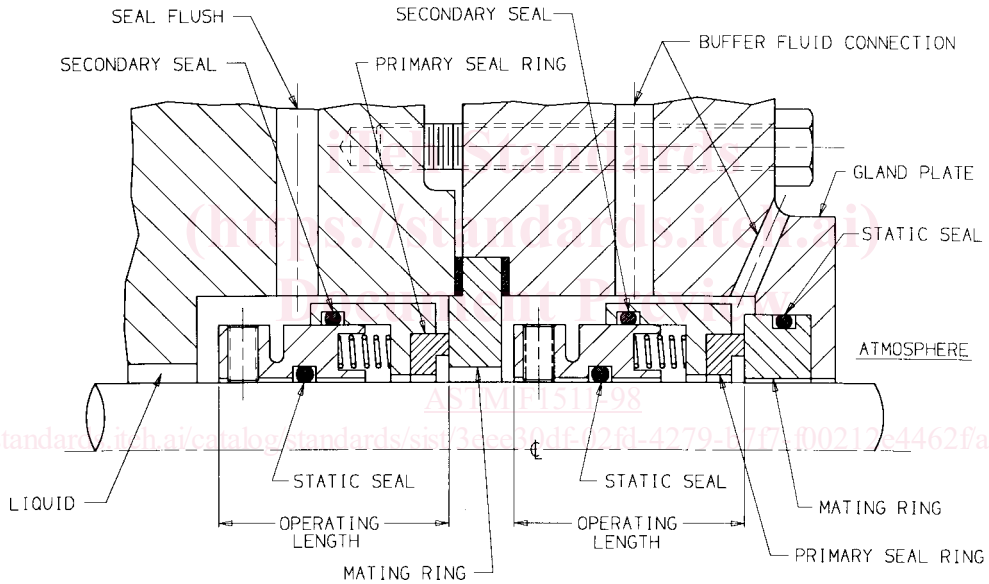

FIG. 6 Tandem Seals Classification Type D Grade 1

- 1.1 *Seal Description*
 Type _____ Grade _____
- 1.2 *Pump Description*
 Pump Mfg. _____ Model _____ Size _____
 Pump S/N _____
 Pump Type (Horizontal, Vertical, etc.) _____
 No. of Stages _____
 Sleeve or Shaft Mat'l _____ Casting Mat'l _____
 Cooling Water Available? _____ °F _____ GPM
 Stuffing Box Water Jacketed? Yes No
 Is Face of Stuffing Box Machined? Yes No
- FILL OUT STUFFING BOX DIMENSIONS SHOWN ON FIG. 8
- 2.1 *Liquid Pumped*
 Fluid _____ Concentration _____ Specify for unique cargo pump fluid application
 Pumping Temperature (°F) Normal _____
 Max _____
 Min _____
 Specific Gravity at Operating Condition _____
 Viscosity Range at Operating Conditions/Temp. _____ SSU
 Vapor Pressure at Operating Conditions/Pressure _____ psig
 Corrosion/Erosion Caused by: _____ % Solids
 Abrasive Separator To be Supplied—Yes _____ No _____
- 2.2 *Operating Conditions*
 Rated Discharge Pressure Max (psig) _____
 Suction Box Pressure Range (psig) _____
 Stuffing Box Pressure Range (psig) _____
 Stuffing Box Temperature Max (°F) _____
 Hydrostatic Test Pressure (psig) _____
 Speed (rpm) _____
 Direction of Rotation From Drive End CW or CCW _____
- 3.1 *Preservation and Packaging*
 Special Preservation & Packaging for Storage & Shipment _____
 Special Marking _____
- 4.1 *Other Special Requirements*
 Seal Manufacturer's Certification of Compliance Required—Yes _____ No _____
- 5.1 *US Navy Application Requirements*
 Supplement S1, ----- Yes _____ No _____
 Check applicable dimensional Table below:
 Table No. S1, Standard Long Mechanical Seal _____
 Table No. S2, Standard Short Mechanical Seal _____
 Table No. S3, Special Cartridge Seals Grade 2 _____
 Table No. S4, Special Seals Grade 1 _____

FIG. 7 Ordering Data Checklist

Material	ASTM
Copper alloy	B 271, B 584, B 505
Bronze	B 62
Alloy 20	B 472 and B 473 (UNS N08020, N08026)
316 stainless steel	A 240/A 240M, A 276, and A 313/A 313M (UNS S316XX)
304 stainless steel	A 182/A 182M, A 313/A 313M (UNS S304XX), A 351/A 351M (CF3, 3A; CF8, 8A; CF8C; CF10)
Alloyed stainless steel (cast)	A 744/A 744M (CN-7M, CN-7MS)
17-4 PH	A 564/A 564M and A 693 (UNS S17400)
AM 350	A 579 (Grade 61)
NiCu ^A	B 164 (UNS N04400, N04405), B 127, A 494/A 494M (Grades M35-1, M35-2, M-30H, M-25S)
NiMo ^B (Alloy C)	B 574 and B 575 (UNS N10276, N06022, N06455)
NiMo	A 494/A 494M (Grades CW-2M, N-12 MV)
NiMo ^C (Alloy B)	B 333 and B 335 (UNS N10001, N10665, N10675)
NiCrFe ^D NiCrMoCo	B 166, B 168
NiCr	B 637, B 670
NiCrMoCb ^E	B 443, B 446
Steel	A 108
Austenitic grey iron	A 436
Titanium	B 338, B 348, B 367
Nickel cast iron (ductile nodular or graphitic)	A 436 Type 1

^AMonel[®] or equivalent has been found satisfactory for this purpose.
^BHastelloy C or equivalent has been found satisfactory for this purpose.
^CHastelloy B or equivalent has been found satisfactory for this purpose.
^DInconel X750[™] or equivalent has been found satisfactory for this purpose.
^EInconel 625[™] or equivalent has been found satisfactory for this purpose.

6.3 *Face Materials*—Mechanical seal-wearing faces shall be selected to provide the desired performance and corrosion resistance for the specified design life of the seal.

6.3.1 Performance ranges for face combinations are listed in Table 2.

6.3.2 Face materials shall be of solid construction only; no overlays, deposited coatings or sprayed on coatings are permitted.

6.3.3 Carbon is preferred for one of the faces unless the service is abrasive, dirty, or chemically active.

6.3.4 For special service requirements, hard on hard seal face combinations may be required. Face material combinations, such as SiC versus SiC, SiC versus TC, and TC versus TC, may be used as similar or dissimilar contacting face materials when recommended by the supplier and approved by the user.

6.4 *Face Material Specifications:*

6.4.1 *Carbon*—Suitable for service as recommended by the manufacturer. Typically carbon graphite composite impregnated with a thermosetting resin.

6.4.2 *Tungsten Carbide*—6 to 10 % nickel or cobalt bound solid tungsten carbide.

6.4.3 *Ceramic*—99.5 % minimum alumina ceramic suitable for the service as recommended by the manufacturer.

6.4.4 *Silicon Carbide*—(a) *Reaction Bonded*—Solid fine grained reaction bonded silicon carbide 8 to 12 % free silicon, essentially free of carbon, impervious structure requiring no impregnant. (b) *Direct Sintered*—Solid homogeneous silicon carbide essentially free of silicon and carbon, impervious structure requiring no impregnant. (c) *Reaction Bonded With Graphite*—A composite material of fine-grain reaction bonded silicon carbide; 5 to 10 % free silicon and 10 to 30 % graphite; impervious structure requiring no impregnant. (d) *Siliconized Carbon Graphite*—Approximately 0.025-in. (0.64-mm) thick conversion of silicon carbide on carbon substructure and impregnated with thermosetting resin.

6.5 *Elastomeric Materials:*

6.5.1 Special care should be given to the selection and installation of elastomeric components, such as bellows and O-rings. One of the most important considerations for elastomers is fluid compatibility. Table 3 references most shipboard applications. Consult the seal manufacturer for fluids not listed.

6.5.2 *Material Classification/Specification:*

6.5.2.1 Nitrile—Specification D 1418 Class Designation NBR.

6.5.2.2 Chloroprene—Specification D 1418 Class Designation CR.

6.5.2.3 Fluorocarbon—Specification D 1418 Class Designation FKM.

6.5.2.4 Ethylene Propylene (EP)—Specification D 1418 Class Designation EPM/EPDM.

6.5.2.5 Perfluoroelastomer—Specification D 1418 Class Designation FFKM.

6.5.2.6 Polytetrafluorethylene (PTFE)—Specification D 3294.

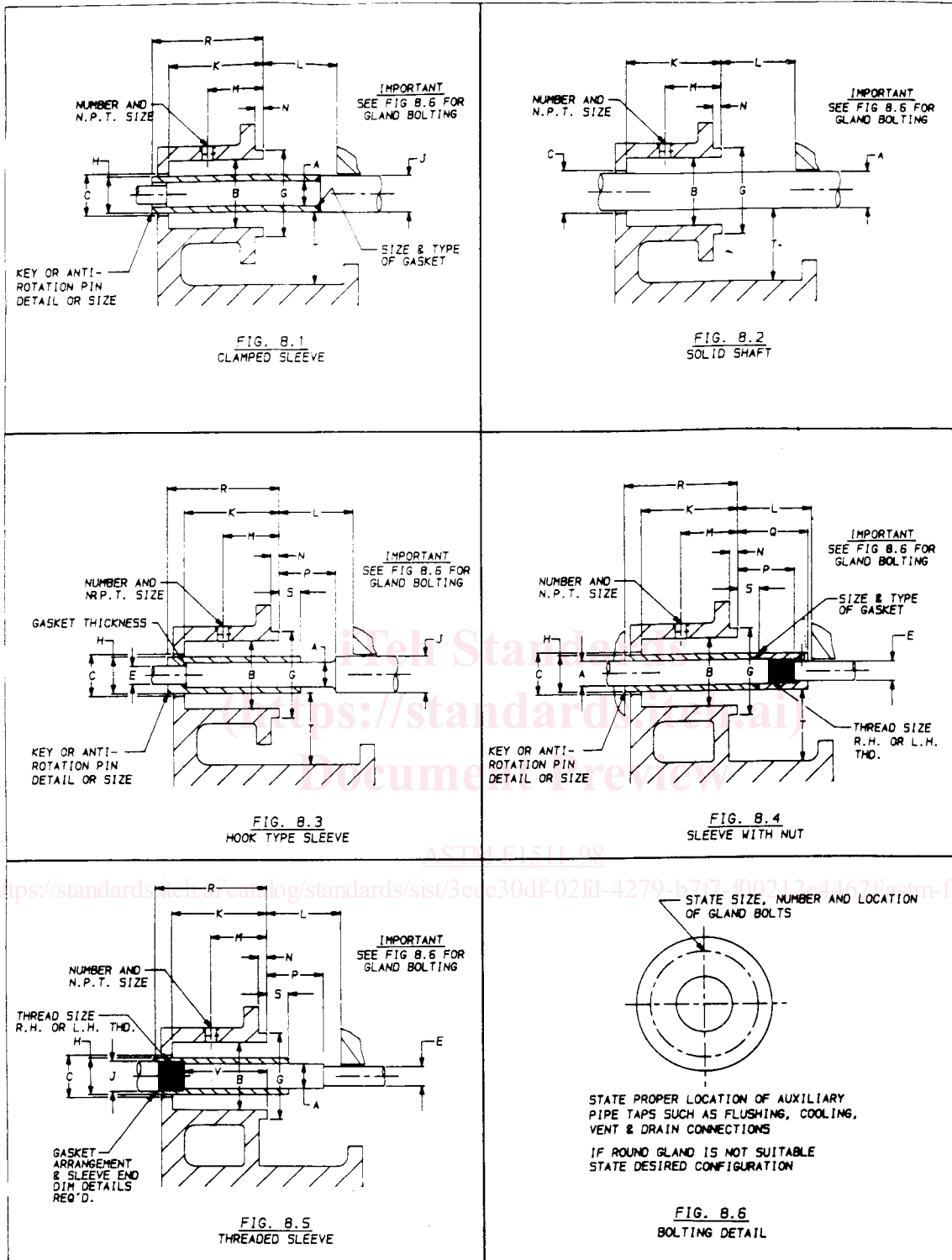

FIG. 8 Stuffing Box Arrangement

6.5.2.7 Corrugated graphite ribbon packing.

6.5.3 Ethylene propylene (EP) rubber shall not be lubricated with any petroleum base substances. Check Section 11 and Appendix X1 or manufacturer's recommendations before using any lubricant.

7. Performance Requirements

7.1 Seal life shall be defined in terms of the time period in

which the mechanical seal functions properly under its specified service.

7.1.1 The minimum operational life of a mechanical seal shall be 16 000 statistical hours provided that the equipment is maintained and operated in accordance with the requirements of Section 8.

7.1.2 During any portion of the service life, the dynamic

A. _____ B. _____ C. _____ D. _____ E. _____ F. _____ G. _____ H. _____ J. _____	K. _____ L. _____ M. _____ N. _____ P. _____ R. _____ S. _____ T. _____ U. _____
N.P.T. _____	
Bolt Holes or Stud Loc. _____	
Thread Size _____	
Auxiliary Pipe Tap Loc. _____	
Comments _____	

FIG. 9 Stuffing Box Dimensions

TABLE 1 Metal Component Compatibility

NOTE 1—For fluids or materials not covered here, seal selection to be mutually agreed upon by seal manufacturer, pump supplier and end user.
 NOTE 2— X = Suitable for use as seal components.

Fluid	Materials ^A						
	Brass	316 Stainless Steel	Ni-Cu	Alloy 20	Highly Alloyed Stainless Steel	Ni-Mo	Ni-Cr-Mo-Cb Ni-Cr-Fe
<i>Fresh Water</i>							
Deminerlized water		X		X	X	X	X
Boiler feed		X		X	X	X	X
Potable	X	X	X	X	X	X	X
<i>Salt Water</i>							
Seawater			X	X	X	X	X
Distiller brine			X		X	X	X
<i>Fuel Oil</i>							
Navy distillate		X	X	X	X	X	X
JP-5		X	X	X	X	X	X
Bunker "C"		X	X	X	X	X	X
NSFO		X	X	X	X	X	X
Diesel		X	X	X	X	X	X
Kerosene		X	X	X	X	X	X
Crude oil		X	X	X	X	X	X
Lube oil		X	X	X	X	X	X
Sewage			X	X	X	X	X

^ASee Section 6 for material specifications.

leakage shall not exceed five drops per minute for Class 0 seals. After initial installation, hydrostatic leakage shall be zero for a 5-min period, when the equipment is subjected to system pressure.

7.1.3 All split mechanical seals, Classes 1 through 4, may experience higher leakage rates than Class 0, solid mechanical seals. A leakage rate of five drops per minute shall be acceptable after completion of the manufacturer's recommended break-in period.

7.1.4 In special applications of extreme environmental parameters such as high temperature with limited cooling; high pressure/velocity; extreme abrasion, unusual equipment vibration, shaft end-play or run-out, the pump and seal manufacturers shall agree upon the best achievable minimum operating life requirements and leakage performance.

7.1.5 Double or special seal arrangements may be required in applications in which zero product leakage to the environ-

ment is required such as hazardous fluids, fuel oil, acids, chemicals and sewage. Consult the seal manufacturer for recommendations.

8. Design Requirements

8.1 *Installation Arrangements:*

8.1.1 Type A mechanical seals shall be provided unless otherwise specified.

8.1.2 Tandem or double mechanical seals may be installed in special applications in which it is determined that a buffer fluid system is required for lubrication, containment, or safety.

8.2 Finish and tolerance requirements for primary seal ring and mating ring surface flatness of Class O mechanicals seals shall be three light bands or better as measured under a monochromatic, helium light source.

8.3 *Requirements for Installation of Classes 1 Through 4 Split Mechanical Seals:*

TABLE 2 Seal Face Materials

NOTE 1—Faces for chemically active materials and special applications shall be agreed upon by seal manufacturer and end user.

Seal Face Compatibility Chart		
Primary Ring	Mating Ring	PV Limit, ^A lb/in. ² × ft/min (MPa·m/s)
Carbon	Tungsten carbide	500 000 (17.75)
Carbon	Silicon carbide	500 000 (17.75)
Carbon	Ceramic ^B	100 000 (3.55)
Siliconized carbon	Tungsten carbide	350 000 (12.43)
Siliconized carbon	Silicon carbide	350 000 (12.43)
Silicon carbide	Tungsten carbide	300 000 (10.65)
Silicon carbide	Silicon carbide	350 000 (12.43)
Tungsten carbide	Tungsten carbide	120 000 ^C (4.26)

^AValues of PV apply to aqueous solutions at 120°F (49°C). For lubricating liquids, such as oil, 60 % higher can be used. Given limits are to be used as a general guide in material selection. Values used consider a pressure drop across the seal faces as 0.5.

^BLimited to chemical service requirements only.

^CPV limit of 185 000 (6.57) can be used with two different grades of tungsten carbide, that is, cobalt versus nickel binders.

8.3.1 Classes 1 through 4, split mechanical seals, may be furnished for shaft/sleeve diameters of 1½ in. (38.1 mm) and above.

8.3.2 For split mechanical seal installations, a minimum of 3 in. (76.2 mm) of axial space, measured from the stuffing box face to the first obstruction, shall be provided for Classes 2 and 4 seals. Additional space, at least equal to the gland thickness, may be required for Classes 1 and 3 seals.

8.3.3 Classes 1 through 4, split mechanical seals, shall be designed to operate under a minimum reverse differential pressure condition of 15-in. Hg (50.8 kPa).

8.4 The requirement for a balanced or unbalanced seal will vary dependent upon the combination of various design and performance factors. Balanced seals shall normally be supplied for pressures greater than 150 psi (1.03 MPa) unless the seal manufacturer provides alternative recommendations for specific applications. Selection of a balanced or unbalanced seal design must satisfy the performance requirements of Section 7.

8.5 The mechanical seal shall be designed to operate satisfactorily under the following:

8.5.1 Shaft sleeve surface finish for pusher-type seals shall be 32 rms (0.80 µm) maximum. Shaft sleeve surface finish for nonpusher seals shall be 64 rms (1.60 µm) maximum.

8.5.2 Shaft radial run-out 0.010 in. (0.25 mm) TIR maximum.

8.5.3 Shaft end-play maximum ± 0.015 in. (0.38 mm).

8.5.4 Concentricity of stuffing box bore to shaft axis 0.005 in. (0.13 mm) TIR maximum. Gland plate design must accommodate eccentricity stated herein.

8.5.5 Perpendicularity of stuffing box face to shaft axis 0.003 in. (0.08 mm) TIR maximum.

8.6 *Environmental Controls*—Environmental control considerations, such as flushing, cooling, heating, and quenching shall be specified by the seal manufacturer.

9. Quality Assurance Provisions

9.1 *Quality Systems*—Mechanical seals shall be supplied in accordance with ISO 9001, Quality Systems—Model for Quality Assurance in Design/Development, Production, Installation, and Service.

9.2 *Responsibility for Inspection*—Unless otherwise specified, the manufacturer is responsible for the performance of all inspection requirements. The manufacturer may use his own or any other facilities suitable for inspection. The buyer reserves the right to perform any of the inspections set forth in the specification where such inspections are deemed necessary to assure supplies and services conform to prescribed requirements.

9.3 *Material Inspection*—The manufacturer shall be responsible for ensuring that materials used are manufactured, examined and tested in accordance with the specifications and standards as applicable.

9.4 *Classification of Inspections*—The inspection requirements specified herein shall be classified as follows:

9.4.1 *Quality Conformance Inspection*

9.4.2 *Inspection of Packaging*

9.5 *Quality Conformance Inspection*—All seal components shall be inspected in accordance with ASQC Z1.4 listing critical, major, and minor characteristics and type of inspection equipment used to determine said characteristics.

9.5.1 *Acceptable Quality Level for Characteristics*—The acceptable quality levels for characteristics, as per ASQC Z1.4, shall be as follows:

9.5.1.1 Critical 1.5 AQL

9.5.1.2 Major 2.5 AQL

9.5.1.3 Minor 4.0 AQL

9.5.2 *Tests*—All tests shall be performed in accordance with ASTM, ASME, or manufacturer's standards as specified.

9.5.3 *Test Data*—All test data shall remain on file at the contractor's facility for review by buyer upon request. It shall be retained in the manufacturer's files for at least three years.

9.6 *Inspection of Packaging:*

9.6.1 *Unit of Product*—For the purpose of inspection, a completed package prepared for shipment shall be considered as a unit of product.

9.6.2 *Sampling*—Sampling for examination shall be in accordance with ASQC Z1.4. The AQL shall be 4.0 % defective.

9.6.3 *Examination*—Samples selected in accordance with 9.5.2 shall be examined for the following defects:

9.6.3.1 Materials, methods, container.

9.6.3.2 Strapping.

9.6.3.3 Consolidated seals not of like description.

9.6.3.4 Marking illegible, incorrect, incomplete, or missing.

9.7 *Warranty*

9.7.1 *Responsibility for Warranty*—Unless otherwise specified, the manufacturer is responsible for the following:

9.7.1.1 All materials used to produce a unit.

9.7.1.2 Workmanship.

9.7.1.3 Manufacturer will warrant his product to be free from defect of workmanship.

9.8 *Certification*—When specified in the purchase order or contract, the purchaser shall be furnished certification that samples representing each lot have been either tested or inspected as directed in this specification and the requirements have been met. When specified in the purchase order or contract, a report of the test results shall be furnished.

10. Packing and Preparation for Delivery

10.1 *Unit of Product*—For the purpose of inspection, a

TABLE 3 Elastomer Compatibility

NOTE 1—X = Suitable for fluids within temperature range indicated.

NOTE 2—NSFO = Navy special fuel oil.

Fluid Temp. Limits: Min Max	Nitrile-N -50°F (-46°C) +250°F (121°C)	Fluorocarbon ^A -25°F (-32°C) +400°F (204°C)	PTFE ^B -150°F (-101°C) +500°F (260°C)	Corrugated Graphite Ribbon -400°F (-46°C) +750°F (400°C)	EP -50°F (-46°C) +300°F (149°C)	Chloroprene -50°F (-46°C) +200°F (93°C)
<i>Fresh Water</i>						
Deminerlized water	X	X	X	X	X	X
Boiler feedwater		X	X	X	X	
Potable water	X	X	X	X	X	X
<i>Salt Water</i>						
Seawater	X	X	X	X	X	X
Distiller brine		X	X	X	X	
<i>Fuel and Lubricants</i>						
Navy distillate	X	X	X	X		X
JP-5	X	X	X	X		X
Bunker C		X	X	X		X
Diesel oil	X	X	X	X		X
Kerosene	X	X	X	X		X
NSFO		X	X	X		
Lube oil (mineral base)		X	X	X		
Sewage	X	X	X	X	X	X

^AFluorocarbon shall be limited to 275°F (135°C) in water.

^BCare should be used in selecting PTFE. Its use is only dictated when other elastomers are not suitable and PTFE is acceptable. PTFE is not acceptable for nuclear service, or in a radiation area. Glass-filled PTFE has a temperature range of -350°F (-212°C) to +500°F (260°C).

completed package prepared for shipment shall be considered as a unit of product.

10.2 *Packaging of Product for Delivery*—Product should be packaged for shipment in accordance with standard industry practice.

10.3 *Instructions*—Instructions and manufacturer's special provisions for handling should be included in complete package.

10.3.1 Each of Classes 1 through 4 split mechanical seals shall be supplied with detailed assembly and installation instructions.

10.3.2 All special or nonstandard tools and fixtures required to assemble and install the seal in the pump shall be identified and supplied with each seal package.

10.4 Any special packaging requirements for shipment or

storage shall be identified in the ordering data. See Section 5.

10.5 *Marking and Coding*—When specified, a mechanical seal marking and coding system shall be used in accordance with Appendix X2.

11. Installation of the Seal Assembly

11.1 Seal suppliers shall provide instructions for each mechanical seal installation to include the applicable information required herein as a minimum.

11.2 Because of the variety of seal types and designs, Appendix X1 is provided for general guidance.

11.3 For specific detailed instructions, consult the seal supplier's installation procedures. For reference to component identification terms, see Section 3 and Annex A1.

SUPPLEMENTARY REQUIREMENTS

The following supplementary requirements established by the U.S. Navy, Commander Naval Sea Systems Command (NAVSEA) shall apply when specified in the contract or purchase order. When there is a conflict between the specifications and this Supplement S1, the requirements of Supplement S1 shall take precedence.

S1. Scope

S1.1 This specification applies to mechanical end face seals for use in U.S. Navy shipboard pumps.

S1.2 Magnetic seals shall not be used.

S2. Referenced Documents

S2.1 *ASTM Standards*:

D 1141 Specification for Substitute Ocean Water⁸

D 3951 Practice for Commercial Packaging¹¹

S2.2 *Military Standards*:

MIL-S-901 Shock Tests, H.I. (High Impact); Shipboard Machinery, Equipment & Systems, Requirements for MIL-P-16789 Packaging of Pumps, Including Prime Movers and Associated Repair Parts

MIL-R-83248 Rubber Fluorocarbon Elastomer, High Temperature, Fluid, and Compression Set Resistant