



Designation: ~~D5706~~—~~11~~ D5706 – 16

Standard Test Method for Determining Extreme Pressure Properties of Lubricating Greases Using a High-Frequency, Linear-Oscillation (SRV) Test Machine¹

This standard is issued under the fixed designation D5706; the number immediately following the designation indicates the year of original adoption or, in the case of revision, the year of last revision. A number in parentheses indicates the year of last reappraisal. A superscript epsilon (ϵ) indicates an editorial change since the last revision or reappraisal.

1. Scope*

1.1 This test method covers a procedure for determining extreme pressure properties of lubricating greases under high-frequency linear-oscillation motion using the SRV test machine. This test method can also be used for evaluating extreme pressure properties of lubricating fluid.

1.2 The values stated in SI units are to be regarded as standard. No other units of measurement are included in this standard.

1.3 *This standard does not purport to address all of the safety concerns, if any, associated with its use. It is the responsibility of the user of this standard to establish appropriate safety and health practices and determine the applicability of regulatory limitations prior to use.*

2. Referenced Documents

2.1 ASTM Standards:²

[A295/A295M Specification for High-Carbon Anti-Friction Bearing Steel](#)

[D217 Test Methods for Cone Penetration of Lubricating Grease](#)

[D4175 Terminology Relating to Petroleum Products, Liquid Fuels, and Lubricants](#)

[D6425 Test Method for Measuring Friction and Wear Properties of Extreme Pressure \(EP\) Lubricating Oils Using SRV Test Machine](#)

[D7421 Test Method for Determining Extreme Pressure Properties of Lubricating Oils Using High-Frequency, Linear-Oscillation \(SRV\) Test Machine](#)

[E45 Test Methods for Determining the Inclusion Content of Steel](#)

[G40 Terminology Relating to Wear and Erosion](#)

2.2 Other Standards:³

[DIN EN ISO 683-17 Heat-treated Steels, alloy steels and free-cutting steels—Part steels—Part 17 : Ball and roller bearing steels](#)

[DIN EN ISO 13565-2:1998 Geometrical Product Specifications \(GPS\)—Surface \(GPS\)—Surface texture: Profile method; Surfaces having stratified functional properties—Part properties—Part 2: Height characterization using linear material ratio curve \(replaces \[Replaces DIN 4776:1990: Measurement of surface roughness; parameters \$R_K\$, \$R_{PK}\$, \$R_{VK}\$, \$M_{T1}\$, \$M_{T2}\$ for the description of the material portion\]portion\]](#)

3. Terminology

3.1 Definitions:

3.1.1 *break-in, n —in tribology*, an initial transition process occurring in newly established wearing contacts, often accompanied by transients in coefficient of friction or wear rate, or both, which are uncharacteristic of the given tribological system's long-term behavior. **G40**

3.1.2 *coefficient of friction, μ or f , n —in tribology*, the dimensionless ratio of the friction force (F) between two bodies to the normal force (N) pressing these bodies together. **G40**

¹ This test method is under the jurisdiction of ASTM Committee D02 on Petroleum Products, Liquid Fuels, and Lubricants and is the direct responsibility of Subcommittee D02.G0.04 on Functional Tests - Tribology.

Current edition approved Dec. 1, 2011; Nov. 15, 2016. Published March 2012; February 2017. Originally approved in 1995. Last previous edition approved in 2011 as D5706-05(2011)D5706-11, ²¹ DOI: 10.1520/D5706-11.10.1520/D5706-16.

² For referenced ASTM standards, visit the ASTM website, www.astm.org, or contact ASTM Customer Service at service@astm.org. For *Annual Book of ASTM Standards* volume information, refer to the standard's Document Summary page on the ASTM website.

³ Available from Deutsches Institut für Normung e.V.(DIN), Burggrafenstrasse 6, 10787 Berlin, Germany, <http://www.din.de>.

*A Summary of Changes section appears at the end of this standard

3.1.3 *Hertzian contact area, n*—the apparent area of contact between two nonconforming solid bodies pressed against each other, as calculated from Hertz’s equations of elastic deformation. **G40**

3.1.4 *Hertzian contact pressure, n*—magnitude of the pressure at any specified location in a Hertzian contact area, as calculated from Hertz’s equations of elastic deformation. The Hertzian contact pressure can also be calculated and reported as maximum value P_{\max} in the centre of the contact or as P_{average} as average over the total contact area. **D7421**

3.1.5 *lubricant, n*—any material interposed between two surfaces that reduces the friction or wear, or both, between them. **D4175**

3.1.6 *lubricating grease, n*—a semi-fluid to solid product of a dispersion of a thickener in a liquid lubricant. **D217**

3.1.6.1 *Discussion*—

The dispersion of the thickener forms a two-phase system and immobilizes the liquid lubricant by surface tension and other physical forces. Other ingredients are commonly included to impart special properties.

3.1.7 *thickener, n*—in *lubricating grease*, a substance composed of finely divided solid particles dispersed in a liquid lubricant to form the grease structure. **D217**

3.1.7.1 *Discussion*—

The thickener can be fibers (such as various metallic soaps) or plates or spheres (such as certain non-soap thickeners) which are insoluble or, at most, only very slightly soluble in the liquid lubricant. The general requirements are that the solid particles be extremely small, uniformly dispersed, and capable of forming a relatively stable, gel-like structure with the liquid lubricant.

3.1.8 *Ra (C.L.A.), n*—in measuring surface finish, the arithmetic average of the absolute distances of all profile points from the mean line for a given distance.⁴

⁴ Amstutz, Hu, “Surface Texture: The Parameters,” Bulletin MI-TP-003-0785, Sheffield Measurement Division, Warner and Swasey, 1985, p. 21.

3.1.8.1 *Discussion*—

C.L.A. means center line average, and it is a synonym for Ra.

3.1.9 *Rpk, n*—reduced peak height according to DIN EN ISO 13565-2:1998. Rpk is the mean height of the peak sticking out above the core profile section.

3.1.10 *Rvk, n*—reduced valley height according to DIN EN ISO 13565-2:1998. Rvk is the mean depth of the valley reaching into the material below the core profile section.

3.1.11 *Rz (DIN), n*—in measuring surface finish, the average of all R_y values (peak to valley heights) in the assessment length.⁵

3.2 *Definitions of Terms Specific to This Standard:*

3.2.1 *extreme pressure, adj*—in *lubrication*—characterized by metal surfaces in contact under high-stress rubbing conditions.

3.2.2 *seizure, n*—localized fusion of metal between the rubbing surfaces of the test pieces.

⁵ Amstutz, Hu, “Surface Texture: The Parameters,” Bulletin MI-TP-003-0785, Sheffield Measurement Division, Warner and Swasey, 1985, pp. 29, 31.

3.2.2.1 *Discussion*—

In this test method, seizure is indicated by a sharp rise in the coefficient of friction, over steady state, of greater than 0.2 for over 20 s. In severe cases, a stoppage in the motor will occur.

3.3 *Abbreviations:*

3.3.1 *SRV, n*—Schwingung, Reibung, Verschleiss (German); oscillating, friction, wear (English translation).

4. Summary of Test Method

4.1 This test method is performed on an SRV test machine using a steel test ball oscillating against a stationary steel test disk with lubricant between them. Test load is increased in ~~100-N~~ 100 N increments until seizure occurs. The load, immediately prior to the load at which seizure occurs, is measured and reported.

NOTE 1—Test frequency, stroke length, temperature, and ball and disk material can be varied to simulate field conditions. The test ball yields point-contact geometry. To obtain line or area contact, test pieces of differing configurations can be substituted for the test balls.



FIG. 1 SRV Test Machine, Model III (left), Model 4 (right)

5. Significance and Use

5.1 This laboratory test method can be used to quickly determine extreme pressure properties of lubricating greases at selected temperatures specified for use in applications where high-speed vibrational or start-stop motions are present with high Hertzian point contact. This test method has found wide application in qualifying lubricating greases used in constant velocity joints of front-wheel-drive automobiles. Users of this test method should determine whether results correlate with field performance or other applications.

6. Apparatus

6.1 *SRV Test Machine, Machines,*⁶ illustrated in ~~Fig. 1~~ Figs. 1-4 and Fig. 2.

7. Reagents and Materials

7.1 *Test Balls, Ball,*⁶ 52100 52100-steel, Rockwell hardness number of 60 ± 2 on Rockwell C scale (HRC), 0.025 ± 0.005 ~~μm~~ $60 \text{ HRC} \pm 2 \text{ HRC}$, $0.025 \mu\text{m} \pm 0.005 \mu\text{m}$ Ra surface finish, ~~10-mm~~ 10 mm diameter.

7.2 *Lower Test Disk,*⁶ ~~vacuum~~ vacuum-arc remelted (VAR) AISI 52100 steel with an inclusion rating using Method D, Type A, as severity level number of 0.5 according to Test Methods E45 and Specification A295/A295M or an inclusion sum value ~~$K1 \leq 10$~~ $K1 \leq 10$ according to DIN EN ISO 683-17 and spherodized annealed to obtain globular carbide, Rockwell hardness number of 60 ± 2 on Rockwell C scale (HRC), $60 \text{ HRC} \pm 2 \text{ HRC}$, the surfaces of the disk being lapped and free of lapping raw materials. The topography of the disk will be determined by four values, ~~24-mm~~ 24 mm diameter by 7.85 mm thick:

- $0.5 \mu\text{m} < \text{Rz (DIN)} < 0.650 \mu\text{m}$
- $0.035 \mu\text{m} < \text{Ra (C.L.A.)} < 0.050 \mu\text{m}$
- $0.020 \mu\text{m} < \text{Rpk} < 0.035 \mu\text{m}$
- $0.050 \mu\text{m} < \text{Rvk} < 0.075 \mu\text{m}$

NOTE 2—The DIN 17230-1980 was replaced by DIN EN ISO 683-17.

7.3 *n-Heptane*, reagent grade. (**Warning**—Flammable. Health hazard.)

7.4 *Isopropanol*, reagent grade. (**Warning**—Flammable. Health hazard.)

7.5 *Toluene*, reagent grade. (**Warning**—Flammable. Health hazard.)

7.6 *Cleaning Solvent*, the test disks have to be cleaned by a liquid solvent (non-chlorinated, non-film forming).

NOTE 3—It is recommended to use a mixture of equal volumes of *n*-heptane, isopropanol, and toluene, all as reagent grades. (**Warning**—Flammable. Health hazard.)

8. Preparation of Apparatus

Preparation of SRV I and II Models

8.1 Turn on the test machine and chart recorder and allow to warm up for 15 min prior to running tests.

8.2 Select the friction data to be presented in the crest peak value position in accordance with the manufacturer's directions.

⁶ The sole source of supply of the apparatus known to the committee at this time is Optimol Instruments Prüftechnik GmbH, Westendstrasse 125, D-80339, Munich Germany, <http://www.optimol-instruments.de>. If you are aware of alternative suppliers, please provide this information to ASTM International Headquarters. Your comments will receive careful consideration at a meeting of the responsible technical committee,¹ which you may attend.

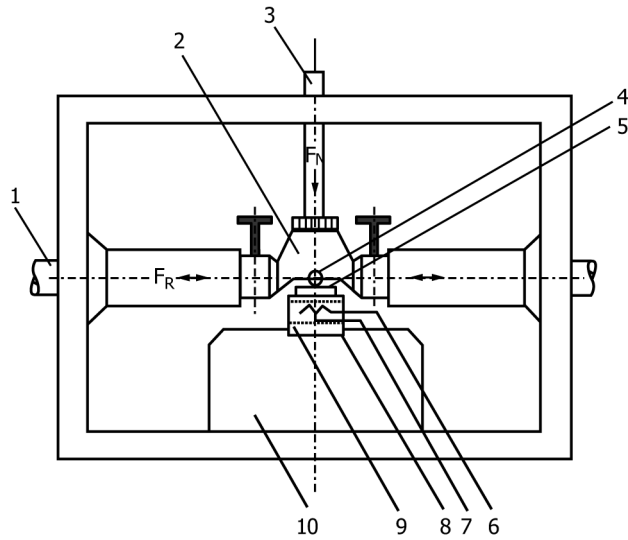

- | | |
|--------------------------|-----------------------------------|
| 1. Oscillation drive rod | 6. Electrical resistance heater |
| 2. Test ball holder | 7. Resistance thermometer |
| 3. Load rod | 8. Test disk holder |
| 4. Test ball | 9. Piezoelectric measuring device |
| 5. Test disk | 10. Receiving block |

FIG. 2 Test Chamber Elements of SRV III

iTeh Standards
 (https://standards.iteh.ai)
 Document Preview

<https://standards.iteh.ai/catalog/standards/sist/b1-00-01-61/cf-4241-8ff1-7a48a571ea77/astm-d5706-16>



FIG. 3 SRV Test Machine, Model IV

NOTE 4—In most cases, this is accomplished by positioning the sliding switch on electronic card NO. 291.35.20E (front side of electronics behind the front panel) and the sliding switch located on the back panel of the control unit.

8.3 Turn the amplitude knob to ZERO.

8.4 Switch the stroke adjustment to AUTO position.

8.5 Set the frequency to 50 Hz.

8.6 Set the desired span and calibrate the chart recorder in accordance with the manufacturer's instructions. Select the desired chart speed.

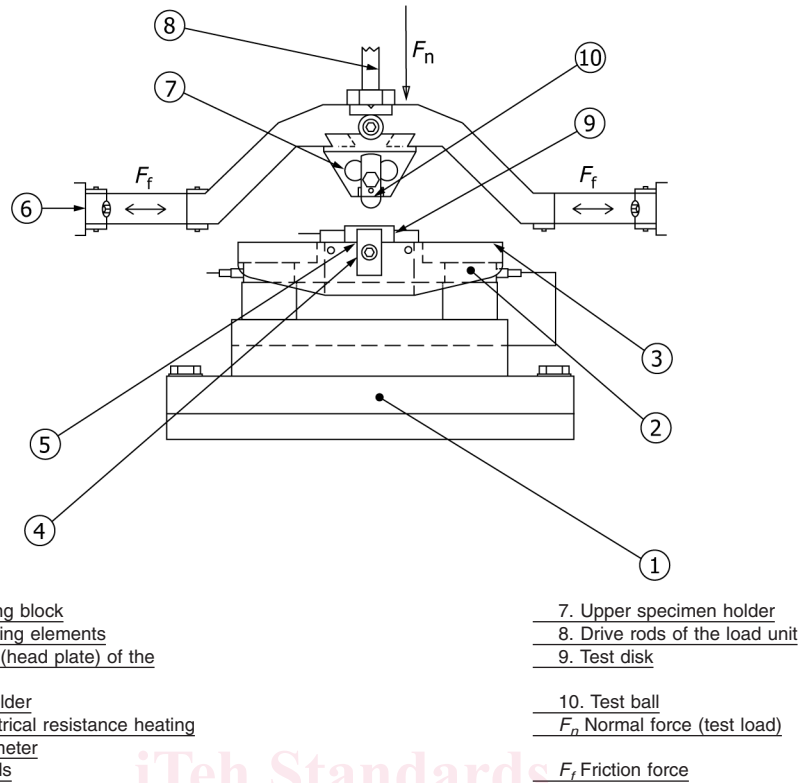

FIG. 4 Test Chamber Elements of SRV Models IV and V

8.7 Turn on the heater control, and preheat the disk holder to the desired temperature. 50 °C, 80 °C, and 120 °C are recommended (see Table 1). When the temperature has stabilized, turn on the chart recorder and depress the drive start toggle switch until the timer begins to count and then adjust the stroke amplitude knob to 2.00 mm.

8.8 Set the load charge amplifier to setting that corresponds to the 400 N load.

8.9 Change the load charge amplifier at each load in accordance with the manufacturer's instructions when the coefficient of friction at each test load is to be studied.

8.10 When the digital timer reaches 30 s, increase the load to 100 N using the slow ramp speed rate, and maintain this load for 15 min.

8.11 The 15 min interval includes the loading ramp sequence. The load has to be increased by 100 N every 2 min using the slow ramp until a load of 1200 N is reached, or the load limit of the test apparatus is attained, or failure occurs. Failure is indicated by a rise in coefficient of friction of greater than 0.2 over steady state for over 20 s or a stoppage in the oscillating of the test machine (see Test Method D5706 or D6425).

NOTE 5—Because a 30 s break-in at 50 N is used, the load increase times will occur on the half minute of even minutes.

8.12 When the 1200 N load run or maximum load of the test apparatus is completed or failure occurs, turn off the heater control, release the load to minimum setting, (typically –13 N or –14 N), and remove the test ball, disk, and lubricating oil test specimen.

Preparation of SRV III, IV, and V Models

8.13 When using SRV III, SRV IV, and SRV V models, clean and install the specimens as specified under 9.1 to 9.7. Turn on the test machine and the PC and allow to warm up for 15 min prior to running tests.

8.14 Create a set point profile in the SRV control software with the following parameters:

NOTE 6—Depending on the software version, names and availability of the parameters can vary.

8.14.1 Start conditions (thermostatic stabilization):

Temperature: for example, 50 °C ± 1 K or 80 °C ± 1 K

Test load: 50 N ± 1 N

Start delay: 300 s (is displayed by all versions of the SRV software)

8.14.2 Cut-off criteria for friction, if occurs:

TABLE 1 Pass Load according to Procedure B in Test Method D5706 of Different Greases using $\Delta x = 1.5$ mm stroke at 80°C or 80°C

NOTE 1—The repeatability and the reproducibility were calculated using [ADJD6300](#) (D2PP software).

NOTE 2—With a mean of ~ 1.100 N, it is not clear that seizures occurred using machines with a highest load of 1200 N.

Year	RR2003	RR2002	RR2001	RR2003	RR2002	RR2001
Test greases, Test Method D5706	Li/Ca-12-OH-Stearat	Li/Ca-12-OH-Stearat	Li/Ca-12-OH-Stearat	PAO Polybuten-bentonit	PAO Polybuten- bentonit	PAO Polybuten/- Bentonit
Modifications	$\Delta x = 1.5$ mm, grease apply caliper, O.K.- load	$\Delta x = 1.5$ mm, grease apply caliper	$\Delta x = 1.5$ mm	$\Delta x = 1.5$ mm, grease apply caliper, O.K.- load	$\Delta x = 1.5$ mm, grease apply caliper	$\Delta x = 1.5$ mm
Statistical Quantities	Highest test load [N]	Highest test load [N]	Highest test load [N]	Highest test load [N]	Highest test load [N]	Highest test load [N]
Number of Results	33	50	56	38	53	54
Degree of freedom	22	28	30	33	27	39
Mean	1088	1180	1028	434	486	505
Standard deviation	± 247	± 235	± 217	± 71.1	± 129	± 106
Reproducibility, R	726	680	627	205	374	303
Repeatability, r	265	267	219	173	201	197

Coefficient of friction, f (cut-off value for permanent increase of level):
0.3 during $t > 20$ s

Coefficient of friction, f (cut-off value for one-off increase of level): 0.35

8.14.3 Test parameters:

Frequency: 50 Hz

Stroke: 1.00 mm for procedure A with 2 min run-in; 1.50 mm for procedure B with 15 min run-in

Temperature: for example, 50°C or 80°C

Pre-load: 50 N for 30 s

Test load: running-in under 100 N for 15 min, then steps of 100 N with a duration of 2 min until the maximum test load (usually 2000 N) has been reached.

Total test duration: up to 53.5 min

NOTE 7—Because a 30 s break-in at 50 N is used, the load increase times will occur on the half minute of even minutes.

NOTE 8—For optimal comparability with older SRV models I and II, the test load should be set as a ramp function with a gradient of 7.5 N/s.

8.14.4 Sample rates for result-relevant measurement channels:

Coefficient of friction, f : ≤ 32 ms

Stroke: ≤ 2 s

Test load: ≤ 2 s

Frequency: ≤ 2 s

Temperature: ≤ 2 s

After that, apply a load increment of 100 N every 2 min.

NOTE 9—For SRV V models, it is recommended to do one sampling per period (that is, 20 ms) for coefficient of friction and stroke.

9. Procedure

9.1 ~~Clean~~ Using solvent-resistant gloves, clean the test ball and disk by wiping the surfaces with laboratory tissue soaked with the cleaning solvent. Repeat wiping until no dark residue appears on the tissue. Immerse the test ball and disk in a beaker of the cleaning solvent under ultrasonic vibration for 10 min. Dry the test ball and disk with a clean tissue to ensure no streaking occurs on the surface.

9.2 Ensure that the test load unit is in the release position (refer to the operating manual for details).

9.3 ~~Procedures~~ Procedure A and B:

9.3.1 Procedure A—Place a small amount (approximately 0.1 g to 0.2 g, the size of a pea) of lubricating grease to be tested on the cleaned test disk in an area such that overlapping with previous wear scars will not occur.

9.3.2 Procedure B—B (since 2005)—Place the grease caliper with 1 mm in height on the cleaned disc. Fill the opening of the grease caliper with grease. Remove any excess grease by means of a spatula. Remove the grease caliper by lifting it upwards. Fasten the disc in the specimen holder.

9.4 Place the cleaned ball, using the tweezers, in the disassembled, cleaned, and dried ball holder. Tighten the fastening screw until resistance just begins. Place the cleaned test ball on the top and in the middle of the lubricating grease specimen so that the lubricating grease makes a circular symmetric pad between the test ball and disk.

9.5 Ensure the machine is unloaded (indicated by a load reading of ~~-13 or -14 N~~) of -13 N or -14 N) and carefully place disk containing the lubricating grease specimen and test ball on the test area platform.

9.6 Tighten both the ball and disk clamps until resistance to tightening just begins. Then load unit to 100 N and tighten the ball and disk clamps to a torque of ~~2.5 N·m~~ 2.5 N·m. Reduce the load to ~~50 N~~ 50 N for break-in.

9.7 Turn on the heater control and set to the desired temperature.

9.8 Set the load charge amplifier to the setting that corresponds to the ~~400-N~~400 N load.

9.9 Change the load charge amplifier at each load in accordance with the manufacturer's instructions when the coefficient of friction at each test load is to be studied.

9.10 When the temperature has stabilized, turn on the chart recorder and depress the drive start toggle switch until the timer begins to count and then adjust the stroke amplitude knob to 1.00 mm for Procedure A and to 1.5 mm for Procedure B.

9.11 When the digital timer reaches 30 s, increase the load to 100 N using the slow ramp speed rate and maintain this load for 2 min for Procedure A and 15 min for Procedure B. The 2 min or 15 min interval includes the loading ramp sequence. Increase the load by 100 N every 2 min using the slow ramp until a load of 1200 N (or 1400 N) is reached, or the load limit of the test apparatus is attained, or failure occurs.

~~9.12 When the digital timer reaches 30 s, increase the load to 100 N using the slow ramp speed rate and maintain this load for 2 min for Procedure A and 15 min for Procedure B. The 2- or 15-min interval includes the loading ramp sequence. Increase the load by 100 N every 2 min using the slow ramp until a load of 1200 N is reached, or the load limit of the test apparatus is attained, or the test is ended when the last test load step has been passed or when failure occurs. Failure is indicated by a rise in coefficient of friction of greater than 0.2 over steady state for over 20 s-20 s or a stoppage in the oscillating of the test machine (see Test Method ~~D6425D7421~~). If no stoppage occurs, the O.K./pass load needs to be determined manually by reading the recording chart for the coefficient of friction (and stroke).~~

NOTE 10—Because a ~~30-s~~30 s break-in at ~~50-N~~50 N is used, the load increase times will occur on the half minute of even minutes.

NOTE 11—The SRV II test machines available after 1992 have a maximum load of 1400 N, and ~~SRVIII-SRV III~~ test machines after 1995 of ~~2000-N~~2000 N, as well as the SRV model IV of 2000 N. Optimol Instruments supplies an upgrade kit to allow ~~SRVIII-SRV I/II~~ machines to operate with ~~1600 N~~1600 N, if needed.

9.13 ~~When the 1200-N~~1200 N load run or maximum load of the test apparatus is completed or failure occurs, turn off the heater control, release the load to minimum setting, (typically ~~-13-13 N or -14 N~~-14 N), and remove the test ball, disk, and lubricating grease test specimen.

10. Report

10.1 Report the following information:

10.1.1 Report all parameters used to evaluate material as follows:

10.1.1.1 Temperature, °C,

10.1.1.2 Stroke, mm,

10.1.1.3 Frequency, Hz,

10.1.1.4 Test ball,

10.1.1.5 Test disk,

10.1.1.6 Lubricating grease test specimen, and

10.1.1.7 Type of procedure—Procedure A or Procedure B.

10.2 Report the highest test load (pass load) at which no seizure ~~occurred~~occurred and when required by specification, include a copy of the friction recording (sample recording chart), which is in general recommended. In SRV models III, IV, and V, friction and stroke can be recorded and displayed simultaneously.

11. Precision and Bias

11.1 Eighteen cooperators tested eight greases at two temperatures having average load carrying capacities in the SRV apparatus ranging from approximately 200 N to approximately ~~700-N~~700 N. The statistical analysis of data from this interlaboratory test program can be obtained from ASTM Headquarters by requesting Research Report RR:D02-1410⁷ or read in Dickey's publication.⁸ The stroke was 1.0 mm for Procedure A.

11.2 The following criteria should be used for judging the acceptability of results (95 % probability) for lubricating greases which have load carrying capacities of ~~1200-N~~1200 N or less in the SRV apparatus using Procedure A with ~~1.0-mm~~1.0 mm of stroke.

11.2.1 *Repeatability*—The difference between successive results obtained by the same operator with the same apparatus under constant operating conditions on identical test material would, in the long run, in the normal and correct operation of the test method, exceed the following values only in one case in twenty.

For tests run at 50°C:0.7X

⁷ Supporting data have been filed at ASTM International Headquarters and may be obtained by requesting Research Report RR:D02-1410. Contact ASTM Customer Service at service@astm.org.

⁸ Dickey, J., "New ASTM and DIN Methods for Measuring Tribological Properties using SRV Test Instrument," *NLGI Spokesman*, March 1997, pp. 17-23.

For tests run at 50 °C: $0.7X$

For tests run at 80 °C: $0.6(X + 122)$

For tests run at 80 °C: $0.6(X + 122)$

where:

where:

X = the average of two results, N .

11.2.2 *Reproducibility*—The difference between two single and independent results obtained by different operators working in different laboratories on identical test materials would, in the long run, exceed the following values only in one case twenty.

For tests run at 50 °C: $1.3X$

For tests run at 50 °C: $1.3X$

For tests run at 80 °C: $1.2(X + 122)$

For tests run at 80 °C: $1.2(X + 122)$

where:

where:

X = the average of two results, N .

11.3 *Bias*—The evaluation of load-carrying capacity of lubricating grease by this test method has no bias because load-carrying capacity can be defined only in terms of the test method.

11.4 Using this ASTM test method for method, the corresponding DIN 51834, part 7, the DIN-DIN 51834 working group conducted international round robin tests with a stroke increase to 1.5 mm in 2001 (with 32 cooperators), 2002 (with 26 cooperators), and 2003 (with 23 cooperators) at 80 °C with two greases using Procedure B, 1.5 mm of stroke, a grease apply caliper, and 15 min of running-in. The results are given in Table 1.⁹

11.5 Using the Procedure B (1.5 mm of stroke) of this ASTM test method, the DIN 51834 working group conducted international round robin tests¹⁰ in 2011 (with 41 cooperators) testing six greases. The precision values from the 2011 round robin test displayed a better precision as those stated in Section 11.

12. Keywords

12.1 extreme pressure; lubricating grease; oscillating; SRV

APPENDIX 16

<https://standards.iteh.ai/catalog/standards/sist/b210af50-61cf-4244-8ff1-7a48a571ea77/astm-d5706-16>
(Nonmandatory Information)

X1. INTERPRETATION OF SEIZURE CRITERIA READING THE COEFFICIENT OF FRICTION IN SAMPLE RECORDING CHART

X1.1 The evolution of the friction force signal is dependent on the type of the grease under test. Different manifestations of the friction force curve need not necessarily be indicative of adhesion having occurred. Figs. X1.1-X1.7 give some typical examples that may guide the user to determine the moment of seizure. These figures were approved by the DIN 51834 working group and D02.G0 in 2003.

⁹ Supporting data have been filed at ASTM International Headquarters and may be obtained by requesting Research Report RR:D02-1565. Contact ASTM Customer Service at service@astm.org.

¹⁰ Supporting data have been filed at ASTM International Headquarters and may be obtained by requesting Research Report RR:D02-1850. Contact ASTM Customer Service at service@astm.org.

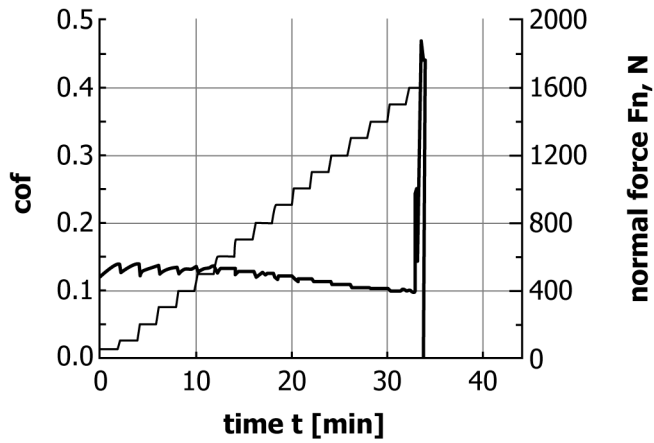

NOTE 1—The sharp and high rise on the friction force at 34 min leads to stopping of the machine and indicates seizure.

iTeh Standards
 (https://standards.iteh.ai)
 Document Preview

ASTM D5706-16

<https://standards.iteh.ai/catalog/standards/sist/bf40af60-61cf-4244-8ff1-7a48a571ea77/astm-d5706-16>

FIG. X1.1 Sample Recording Chart During Step Load Test

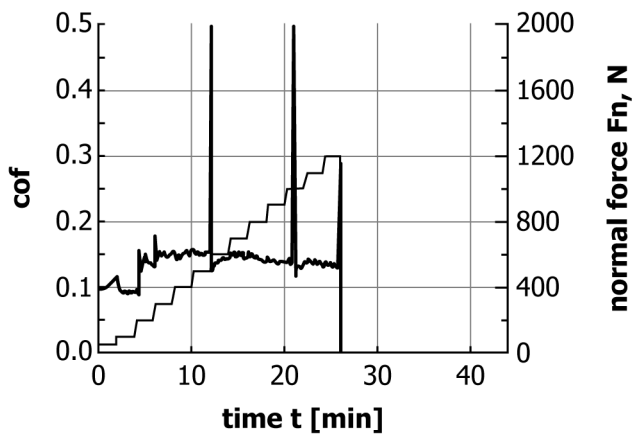

NOTE 1—The sharp and high rise on the friction force at 12 and 21 min are not considered as seizure indication, since the level of coefficient of friction remained unchanged. Seizure load is the stopping of the machine at 26 min.

iTeh Standards
 (https://standards.iteh.ai)
 Document Preview

[ASTM D5706-16](https://standards.iteh.ai/catalog/standards/sist/bf40af60-61cf-4244-8ff1-7a48a571ea77/astm-d5706-16)

<https://standards.iteh.ai/catalog/standards/sist/bf40af60-61cf-4244-8ff1-7a48a571ea77/astm-d5706-16>