



Designation: F1957 – 99 (Reapproved 2017)

Standard Test Method for Composite Foam Hardness-Durometer Hardness¹

This standard is issued under the fixed designation F1957; the number immediately following the designation indicates the year of original adoption or, in the case of revision, the year of last revision. A number in parentheses indicates the year of last reapproval. A superscript epsilon (ϵ) indicates an editorial change since the last revision or reapproval.

1. Scope

1.1 This test method describes a type of composite foam hardness measurement device known as durometer: Type CF. The procedure for determining indentation hardness of substances comprised of two or more elastomeric materials, one of which is a foam or foam like material. These are classified as composite foam structures. The composite foam product may have an armature made of a material suitable for adding structural integrity including but not limited to metal, plastic, or wood. This construction is typical for lapbar restraints, seating, and other restraint devices, as well as some show elements.

1.2 This test method is not equivalent to other indentation hardness methods and instrument types, specifically those described in Test Methods D1415 and D2240.

1.3 The values stated in SI units are to be regarded as standard. The values given in parentheses are for information only. Many of the stated dimensions in SI are direct conversions from the U.S. customary system to accommodate the instrumentation, practices, and procedures that existed prior to the Metric Conversion Act of 1975.

1.4 All materials, instruments, or equipment used for the determination of mass or dimension shall have traceability to the National Institute for Standards and Technology (NIST) or other internationally recognized organizations.

1.5 This test method is not a safety standard as it pertains to ride legislation. The use of this test method is optional based upon an agreement between customers and suppliers of foam products.

1.6 *This standard does not purport to address all of the safety concerns, if any, associated with its use. It is the responsibility of the user of this standard to establish appropriate safety and health practices and determine the applicability of regulatory limitations prior to use.*

¹ This test method is under the jurisdiction of ASTM Committee F24 on Amusement Rides and Devices and is the direct responsibility of F24.10 on Test Methods.

Current edition approved Feb. 1, 2017. Published March 2017. Originally approved in 1999. Last previous edition approved in 2011 as F1957 – 99 (2011). DOI: 10.1520/F1957-99R17.

2. Referenced Documents

2.1 *ASTM Standards*:²

D374 Test Methods for Thickness of Solid Electrical Insulation (Metric) D0374_D0374M

D618 Practice for Conditioning Plastics for Testing

D785 Test Method for Rockwell Hardness of Plastics and Electrical Insulating Materials

D1349 Practice for Rubber—Standard Conditions for Testing

D1415 Test Method for Rubber Property—International Hardness

D2240 Test Method for Rubber Property—Durometer Hardness

D4483 Practice for Evaluating Precision for Test Method Standards in the Rubber and Carbon Black Manufacturing Industries

3. Summary of Test Method

3.1 This test method permits hardness measurements based on either initial indentation or indentation after a specified period of time, or both.

3.2 Those specimens, which have a durometer hardness range other than specified, shall use another suitable procedure for determining durometer hardness.

4. Significance and Use

4.1 This test method is based on the penetration by a specific type of indenter when forced into the material under specified conditions. The indentation hardness is related inversely to the penetration and is dependent on the elastic modulus and viscoelastic behavior of the material. The geometry of the indenter and the applied force influence the measurements, such that no simple relationship exists between the measurements obtained with one type of durometer and those obtained with another type of durometer or other instruments used for measuring hardness. This test method is an empirical test intended primarily for control purposes. No simple relationship exists between indentation hardness determined by this test method and any fundamental property of the

² For referenced ASTM standards, visit the ASTM website, www.astm.org, or contact ASTM Customer Service at service@astm.org. For *Annual Book of ASTM Standards* volume information, refer to the standard's Document Summary page on the ASTM website.

material tested. For specification purposes it is recommended that Test Method D785 be used for hard materials and Test Method D2240 be used for solid elastomers.

5. Apparatus

5.1 Hardness measurement apparatus, or durometer, consisting of the following components:

5.1.1 *Presser Foot*, with an orifice (to allow for the protrusion of the indentor) having a diameter as specified in Fig. 1 with the center a minimum of 38.0 mm (1.5 in.) from any edge of the flat circular presser foot.

5.1.2 *Indentor*, formed from steel rod, shaped in accordance with Fig. 2, polished over the contact area so that no flaws are visible under 20× magnification and with an indentor extension of 7.62 ± 0.04 mm ($.300 \pm 0.002$ in.).

5.1.3 *Indentor Extension Indicating Display*, (analog or digital electronic), having a display that is an inverse function of the indentor extension.

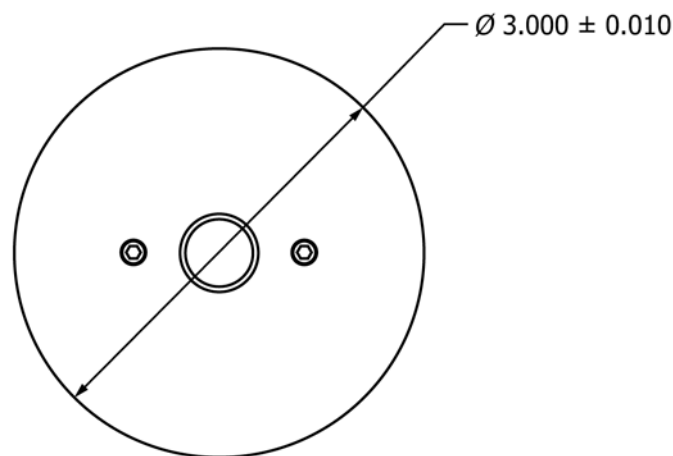
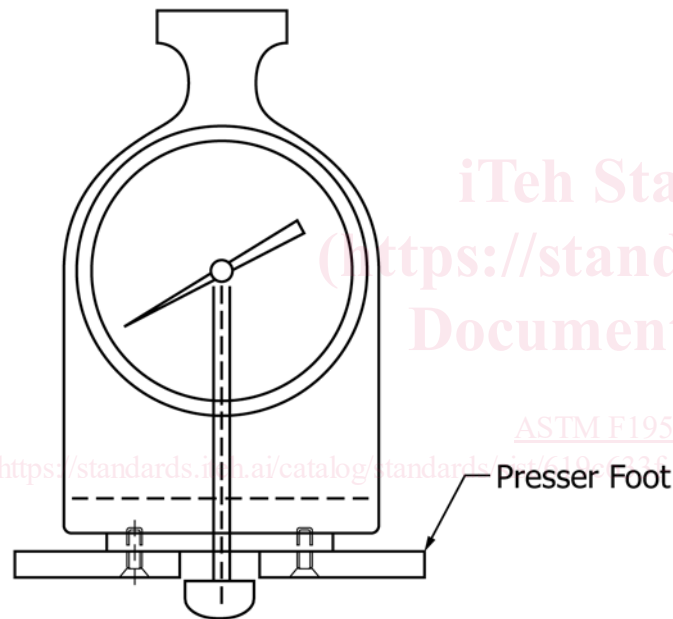

FIG. 1 Presser Foot Detail

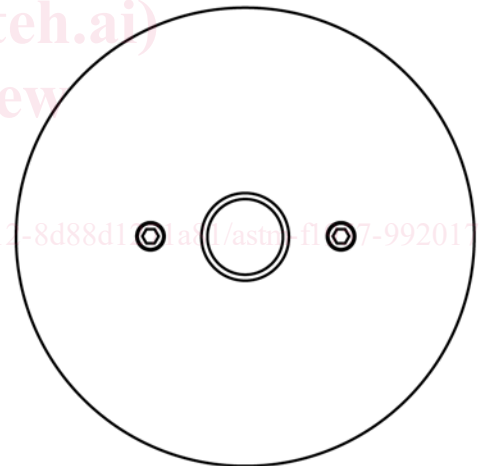
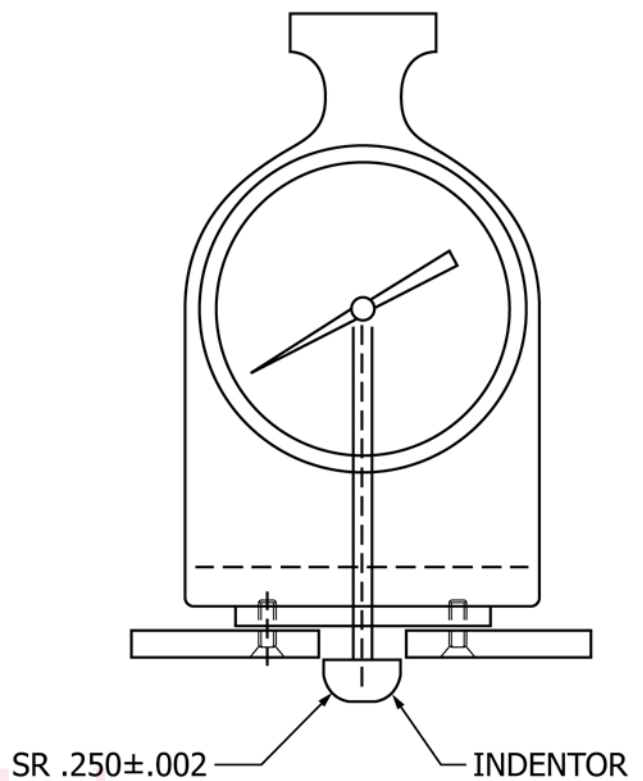

FIG. 2 Indentor Detail

5.1.3.1 *Digital Electronic Indicating Displays* shall indicate from 0 to 100, with no less than 100 equal divisions throughout the range, at a rate of one hardness point for each 0.50 mm (0.002 in.) of indenter movement.

5.1.3.2 *Analog Indicating Displays* shall indicate from 0 to 100, with no less than 100 equal divisions throughout the range or alternatively with no less than 90 equal divisions throughout a range from 10 to 100, at a rate of one hardness point for each 0.050 mm (0.002 in.) of indenter movement.

5.1.4 *Maximum Indicators* (optional), maximum indicating pointers are auxiliary analog indicating hands designed to remain at the maximum hardness value attained until reset by

the operator. Electronic maximum indicators are digital displays electronically indicating and maintaining the maximum value hardness value achieved, until reset by the operator.

5.1.4.1 Analog maximum indicating pointers have been shown to have a nominal influence on the values attained; however, this influence is greater on durometers of lesser total mainspring forces. The influence of a maximum indicating pointer shall be noted at the time of calibration in the calibration report (see 10.1.4) and when reporting hardness determinations (see 10.2.4).

5.1.4.2 Digital electronic durometers may be equipped with electronic maximum indicators that shall not influence the indicated reading or determinations attained by more than one half of the calibration tolerance stated in Table 1.

5.1.5 *Calibrated Spring*, for applying force to the indenter and capable of applying the forces as specified in Table 1.

6. Test Specimen

6.1 The test specimen, herein referred to as “specimen” or “test specimen” interchangeably, shall be at least 25.4 mm (1.00 in.) thick, herein, unless it is known that results equivalent to the 25.4 mm (1.00 in.) values are obtained with a thinner test specimen. On specimens with solid armatures, it is suggested that readings not be taken in areas close to the armature as this may affect the readings.

6.1.1 The lateral dimensions of the test specimen shall be sufficient to permit measurements at least 12.0 mm (0.48 in.) from any edge unless it is known that identical results are obtained when measurements are made at a lesser distance from an edge.

6.1.2 The surfaces of the test specimen shall be flat and parallel over a sufficient area to permit the presser foot to contact the specimen over an area having a radius of at least 30.0 mm (1.18 in.) from the indenter point if possible. Variations are acceptable as agreed upon between laboratories or between customer and supplier. The test specimen shall be supported suitably to provide for positioning and stability. A

suitable hardness determination may be difficult to obtain on an uneven or rough point of contact with the indenter.

7. Calibration

7.1 *Calibration Device*—The durometer spring shall be calibrated by supporting the durometer in a calibrating device in a vertical position and applying a measurable force to the indenter tip. The force may be measured by means of a balance or by an electronic force cell. The calibrating device shall be capable of measuring applied force to within 50 % of the calibration tolerance described in Table 1. Care should be taken to ensure that the force is applied vertically to the indenter tip, as lateral force will cause errors in calibration.

7.2 *Indenter Extension*—Indenter extension and shape shall be in accordance with 5.1.2 and Fig. 2.

7.3 *Indenter Extension Adjustment Procedure:*

7.3.1 *Dimensional Gage Blocks:*

7.3.1.1 The presser foot must be attached to the durometer gage before adjustment. This allows a nominal indenter extension of 7.62 mm (0.300 in.).

7.3.1.2 Place precision ground dimensional blocks (Grade B or better) on the test specimen support table and beneath the durometer presser foot and indenter. Arrange the blocks so that the durometer presser foot contacts the larger block and the indenter tip is at the moment of contact with the smaller block (Fig. 3).

7.3.1.3 A combination of dimensional gage blocks may be used to achieve a difference of 7.62 +0.00, – 0.0254 mm (0.300 +0.00, –0.001 in.) between them:

7.3.2 *Indenter Extension Adjustment:*

7.3.2.1 Carefully lower the durometer presser foot until contact with the largest dimensional block, the indenter tip should be at the point of contact with the smaller block, verifying full indenter extension.

7.3.2.2 Adjust the indenter extension to 7.620 ± 0.04 mm (0.300 ± 0.002 in.), following the manufacturer’s recommended procedure.

7.3.2.3 When performing the procedures in 7.3, care should be used as not to cause damage to the indenter tip.

7.3.2.4 Parallelism of the durometer presser foot to the test specimen support surface (table), and hence the dimensional gage blocks, at the time of instrument calibration shall be in accordance with Test Methods D374, machinist’s micrometers.

7.4 *Indicator Display Adjustment (Analog and Digital):*

7.4.1 After adjusting the indenter extension as indicated in 7.3, use an identical arrangement of dimensional gage blocks to verify the linear relationship between indenter travel and indicated display at two points: 0 and 100. Following the manufacturer’s recommendations, make adjustments so that the indicator displays a value equal to the indenter travel measured to within:

- ±½ durometer units measured at 0;
- ±½ durometer units measured at 100, and
- ±1½ durometer units at all points enumerated in 7.5.

7.4.2 Each durometer point indicated is equal to 0.050 mm (0.002 in.) of indenter travel.

TABLE 1 Durometer Spring Force Calibration

| Indicated Value | Force, N | Force, lbf |
|-----------------------|----------|------------|
| 0 | 1.099 | 0.247 |
| 10 | 9.928 | 2.232 |
| 20 | 18.757 | 4.217 |
| 30 | 27.586 | 6.202 |
| 40 | 36.415 | 8.186 |
| 50 | 45.244 | 10.171 |
| 60 | 54.073 | 12.156 |
| 70 | 62.902 | 14.141 |
| 80 | 71.731 | 16.126 |
| 90 | 80.560 | 18.111 |
| 100 | 89.389 | 20.095 |
| Calibration Tolerance | ±0.893 | ±0.200 |