



Designation: C1129 – 17

Standard Practice for Estimation of Heat Savings by Adding Thermal Insulation to Bare Valves and Flanges¹

This standard is issued under the fixed designation C1129; the number immediately following the designation indicates the year of original adoption or, in the case of revision, the year of last revision. A number in parentheses indicates the year of last reapproval. A superscript epsilon (ϵ) indicates an editorial change since the last revision or reapproval.

1. Scope

1.1 The mathematical methods included in this practice provide a calculational procedure for estimating heat loss or heat savings when thermal insulation is added to bare valves and flanges.

1.2 Questions of applicability to real systems should be resolved by qualified personnel familiar with insulation systems design and analysis.

1.3 Estimated accuracy is limited by the following:

1.3.1 The range and quality of the physical property data for the insulation materials and system,

1.3.2 The accuracy of the methodology used in calculation of the bare valve and insulation surface areas, and the quality of workmanship, fabrication, and installation.

1.4 This procedure is considered applicable both for conventional-type insulation systems and for removable/reuseable covers. In both cases, for purposes of heat transfer calculations, the insulation system is assumed to be homogeneous.

1.5 This practice does not intend to establish the criteria required in the design of the equipment over which thermal insulation is used, nor does this practice establish or recommend the applicability of thermal insulation over all surfaces.

1.6 The values stated in inch-pound units are to be regarded as standard. The values given in parentheses are mathematical conversions to SI units that are provided for information only and are not considered standard.

¹ This practice is under the jurisdiction of ASTM Committee C16 on Thermal Insulation and is the direct responsibility of Subcommittee C16.30 on Thermal Measurement.

Current edition approved March 1, 2017. Published March 2017. Originally approved in 1989. Last previous edition approved in 2012 as C1129 – 12. DOI: 10.1520/C1129-17.

1.7 *This standard does not purport to address all of the safety concerns, if any, associated with its use. It is the responsibility of the user of this standard to establish appropriate safety and health practices and determine the applicability of regulatory limitations prior to use.*

2. Referenced Documents

2.1 *ASTM Standards:*²

C168 Terminology Relating to Thermal Insulation

C450 Practice for Fabrication of Thermal Insulating Fitting Covers for NPS Piping, and Vessel Lagging

C680 Practice for Estimate of the Heat Gain or Loss and the Surface Temperatures of Insulated Flat, Cylindrical, and Spherical Systems by Use of Computer Programs

C1695 Specification for Fabrication of Flexible Removable and Reusable Blanket Insulation for Hot Service

2.2 *ASTM Adjuncts:*³

ADJJC0450A Recommended Dimensional Standards for Fabrication of Thermal Insulating Fitting Covers for NPS Piping and Vessel Lagging

2.3 *American National Standards Institute Standard:*

ANSI B16.5 Fittings, Flanges, and Valves⁴

3. Terminology

3.1 *Definitions*—For definitions of terms used in this practice, refer to Terminology C168.

3.2 *Symbols:*

² For referenced ASTM standards, visit the ASTM website, www.astm.org, or contact ASTM Customer Service at service@astm.org. For *Annual Book of ASTM Standards* volume information, refer to the standard's Document Summary page on the ASTM website.

³ Available from ASTM International Headquarters. Order Adjunct No. ADJADJC0450A. Original adjunct produced in 1976. Adjunct last revised in 2002.

⁴ Available from American National Standards Institute (ANSI), 25 W. 43rd St., 4th Floor, New York, NY 10036, <http://www.ansi.org>.

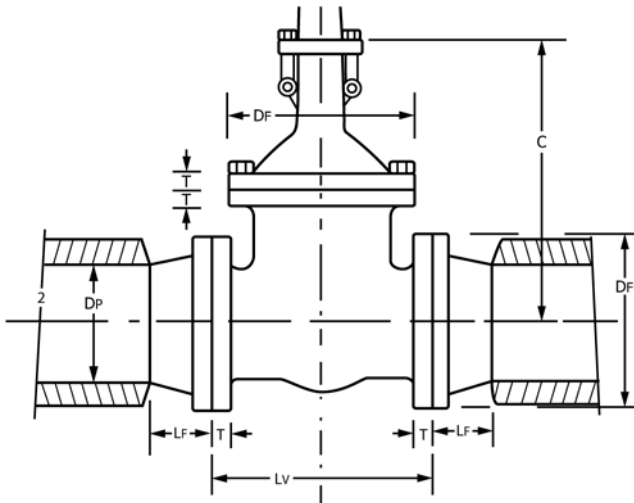

FIG. 1 Equation 1 for a for the Surface Area of Bare Valve, A_{Bv}
 $= [D_p(L_v + 2L_f + (C - D_p/2) - 6T) + 1.5(D_f^2 - D_p^2) + 6 D_f T] \pi$ (Ref. 3)

4. Summary of Practice

4.1 The procedures for estimating heat loss used in this practice are based upon standard steady-state heat transfer theory as outlined in Practice C680 (or programs conforming to it such as 3E Plus⁵). Practice C680 and 3E plus are used to estimate the heat loss per unit surface area for the particular conditions and for all configurations, both bare and insulated.

4.2 The procedures for estimating surface areas used in this practice are based on standard geometric logic: for a bare valve or flange, the contours of the metal surface are considered. For an insulated valve or flange, the fabricated shape of the finished insulation system is considered.

4.3 Data Input:

- 4.3.1 Total bare surface area and total insulation surface area of the valve or flange,
- 4.3.2 Service and ambient temperatures,
- 4.3.3 Wind speed,
- 4.3.4 Surface emittance values
- 4.3.5 Insulation thickness and type, and
- 4.3.6 Number of service hours per year.

4.4 *System Description*—Insulation thickness, insulation type, bare valve or flange surface emittance, insulation surface emittance.

4.5 *Analysis*—Once input data is entered, the program calculates the surface coefficients (if not entered directly), the insulation resistance, the bare metal heat loss per unit area, and the insulation surface heat loss per unit area. The rate of heat loss per unit area is computed by Practice C680 for the appropriate diameter. For bare gate valves, the particular surface area can be taken from a look-up table. Table 1 and Table 2 give these areas for typical (ANSI Class 150, 300, 600, and 900) flanged gate valves and flanges. If these valves are not considered sufficiently accurate for the particular valves or flanges being considered, those areas can be calculated using Eq 1 (see Fig. 1) for bare flanges and Eq 2 (see Fig. 2) for bare gate valves. Similar equations can be developed for other types of valves and flanges. For the insulation on the valves and the flanges, the outer surface area can be obtained either from Table 3 and Table 4 for insulation thickness up to 4 in. or from the insulation fabricator or contractor.

5. Significance and Use

5.1 Manufacturers of thermal insulation for valves typically express the performance of their products in charts and tables showing heat loss per valve. These data are presented for both bare and insulated valves of different pipe sizes, ANSI classes, insulation types, insulation thicknesses, and service temperatures. Additional information on effects of wind velocity, jacket emittance, bare valve emittance, and ambient conditions are also required to properly select an insulation system. Due to the infinite combination of pipe sizes, ANSI classes, insulation types and thicknesses, service temperatures, insulation cover geometries, surface emittance values, and ambient conditions, it is not possible to publish data for each possible case.

⁵ Available from the North American Insulation Manufacturers Association for a free download. <http://www.pipeinsulation.org>.

3.2.1 The following symbols are used in the development of the equations for this practice. Other symbols will be introduced and defined in the detailed description of the development. See Fig. 1 and Fig. 2.

- A_B = outer surface area of the bare valve or flange (does not include the wheel and stem of the valve), ft² (m²).
- A_I = surface area of the insulation cover over the valve or flange, ft² (m²).
- C = distance from the center-line axis of the pipe (to which the valve is attached) to the uppermost position of the valve that is to be insulated (recommended to be below the gland seal), ft (m).
- D_F = the valve flange and the bonnet flange outer diameter (assumed equal), ft (m).
- D_P = the actual diameter of the pipe, ft (m).
- L_V = overall length of the valve, flange to flange, ft (m).
- T = thickness of the valve flange and of the bonnet flange, ft (m).
- q_B = time rate of heat loss per unit area from the bare valve or flange surface, Btu/h-ft² (W/m²).
- q_I = time rate of heat loss per unit area from the insulation surface, Btu/h-ft² (W/m²).
- Q_B = time rate of heat loss from the bare valve or flange surface, Btu/h (W).
- Q_I = time rate of heat loss from the insulated surface, Btu/h (W).

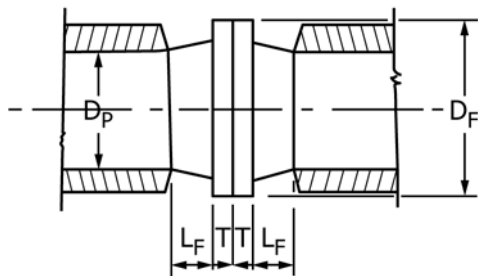

FIG. 2 Equation 2 for the surface area of a Bare Flange, A_{BF}
 $2L_f + (D_f^2 - D_p^2) / 2 + 2 D_f T]$

TABLE 1 Calculated Surface Areas of Bare Valves using Eq 1 (Ref 3)

NPS, in.	ANSI Class			
	150	300	600	900
	ft ² (m ²)	ft ² (m ²)	ft ² (m ²)	ft ² (m ²)
2	2.21 (0.205)	2.94 (0.273)	2.94 (0.273)	5.20 (0.483)
2½	2.97 (0.276)	3.51 (0.326)	3.91 (0.363)	6.60 (0.613)
3	3.37 (0.313)	4.39 (0.408)	4.69 (0.436)	6.50 (0.604)
4	4.68 (0.435)	6.06 (0.563)	7.64 (0.710)	9.37 (0.870)
6	7.03 (0.653)	9.71 (0.902)	13.03 (1.210)	15.80 (1.468)
8	10.30 (0.957)	13.50 (1.254)	18.40 (1.709)	23.80 (2.211)
10	13.80 (1.284)	18.00 (1.672)	26.50 (2.462)	32.10 (2.982)
12	16.10 (1.496)	24.10 (2.239)	31.90 (2.964)	41.90 (3.893)
14	22.80 (2.118)	32.50 (3.019)	39.70 (3.688)	48.20 (4.478)
16	27.60 (2.564)	39.30 (3.651)	50.50 (4.691)	57.00 (5.295)
18	31.70 (2.945)	49.40 (4.589)	59.80 (5.555)	69.70 (6.475)
20	37.70 (3.502)	59.10 (5.490)	71.30 (6.624)
24	49.10 (4.561)	83.50 (7.757)	95.10 (8.835)
30	72.20 (6.707)	123.30 (11.46)	141.70 (13.6)
36	107.30 (9.968)	164.00 (15.24)	199.00 (18.49)

TABLE 2 Calculated Flange Pair Surface Areas using Eq 2

Bare surface areas in square feet (square meters) for ANSI Classes 150, 300, 600, and 900

NPS, in.	150		300		600		900	
	ft ²	(m ²)	ft ²	(m ²)	ft ²	(m ²)	ft ²	(m ²)
	2	0.71	0.066	0.84	0.078	0.88	0.081	1.54
3	1.06	0.099	1.32	0.122	1.36	0.127	1.85	0.172
4	1.44	0.133	1.83	0.170	2.23	0.208	2.64	0.245
6	2.04	0.190	2.72	0.252	3.60	0.334	4.37	0.406
8	2.92	0.271	3.74	0.348	4.89	0.454	6.40	0.595
10	3.68	0.342	4.80	0.446	6.93	0.643	8.47	0.787
12	5.01	0.465	6.34	0.589	7.97	0.740	10.43	0.969
14	6.15	0.571	7.90	0.734	9.16	0.851	11.59	1.077
16	7.19	0.668	9.25	0.859	11.49	1.067	13.34	1.239
20	9.40	0.873	12.50	1.161	15.18	1.411	19.12	1.776
24	11.82	1.099	16.23	1.507	19.30	1.793	28.18	2.618

5.2 Users of thermal insulation for piping systems faced with the problem of designing large systems of insulated piping, encounter substantial engineering costs to obtain the required thermal information. This cost can be substantially reduced by both the use of accurate engineering data tables, or by the use of available computer analysis tools, or both.

5.3 The use of this practice by the manufacturer, contractor, and users of thermal insulation for valves and flanges will provide standardized engineering data of sufficient accuracy and consistency for predicting the savings in heating energy use by insulating bare valves and flanges.

5.4 Computers are now readily available to most producers and consumers of thermal insulation to permit use of this practice.

5.5 The computer program in Practice C680 has been developed to calculate the heat loss per unit length, or per unit surface area, of both bare and insulated pipe. With values for bare valve or flange surface areas, heat loss can be estimated. By estimating the outer insulation surface area from an insulation manufacturer's or contractor's drawings, the heat loss from the insulation surface can likewise be calculated by taking the product of heat loss per unit area (from programs conforming to Practice C680) and the valve or flange insulation surface area. The area of the uninsulated surfaces also will need to be considered.

5.6 The use of this practice requires that the valve or flange insulation system meets either Specification C1695 for removeable/reuseable or the Adjunct to Practice C450³ for insulation fabricated from rigid board and pipe insulation.

6. Calculation

6.1 This calculation of heat gain or loss requires the following:

6.1.1 The thermal insulation shall be assumed to be homogeneous as outlined by the definition of thermal conductivity in Terminology C168.

6.1.2 The valve or flange size and operating temperature shall be known.

6.1.3 The insulation thickness shall be known.

6.1.4 Values of wind speed and surface emittance shall be available to estimate the surface coefficients for both the bare surface and for the insulation.

6.1.5 The surface temperature in each case shall be assumed to be uniform.

6.1.6 The bare surface dimensions or area shall be known.

6.1.7 The outer surface area of the insulation cover can be estimated from drawings or field measurements.

6.1.8 Practice C680 or other comparable methodology shall be used to estimate the heat loss from both bare and insulated surfaces.

TABLE 3 Calculated Insulated Gate Valve Surface Areas

Table 3A - 150 psi gate valves - insulated Surface Area, sf (sm) for four different insulation thicknesses								
NPS, in.	1 in.	25 mm	2 in.	51 mm	3 in.	76 mm	4 in.	102 mm
2	4.21	0.392	4.64	0.43	6.31	0.59	8.25	0.77
3	5.24	0.487	5.73	0.53	7.30	0.68	9.30	0.86
4	7.15	0.664	7.72	0.72	8.60	0.80	10.60	0.99
6	9.67	0.898	10.29	0.96	11.70	1.09	14.18	1.32
8	12.49	1.160	12.29	1.14	15.89	1.48	17.26	1.60
10	15.03	1.396	15.85	1.47	17.41	1.62	19.99	1.86
12	20.80	1.932	21.58	2.01	23.39	2.17	25.50	2.37
14	24.50	2.276	25.27	2.35	27.29	2.54	29.33	2.72
16	33.27	3.091	34.30	3.19	36.64	3.40	39.07	3.63
20	38.66	3.592	39.63	3.68	41.98	3.90	48.01	4.46
24	45.98	4.272	46.97	4.36	49.50	4.60	52.12	4.84

Table 3B - 300 psi gate valves - insulated Surface Area, sf (sm) for four different insulation thicknesses								
NPS, in.	1 in.	25 mm	2 in.	51 mm	3 in.	76 mm	4 in.	102 mm
2	6.36	0.591	7.16	0.67	9.42	0.88	12.87	1.20
3	11.44	1.063	12.96	1.20	15.74	1.46	18.72	1.74
4	15.31	1.422	16.64	1.55	19.75	1.83	23.10	2.15
6	20.24	1.880	21.71	2.02	25.28	2.35	28.98	2.69
8	NA	NA	27.43	2.55	31.29	2.91	35.44	3.29
10	NA	NA	35.24	3.27	39.67	3.69	44.32	4.12
12	NA	NA	45.72	4.25	50.71	4.71	55.93	5.20
14	NA	NA	58.32	5.42	64.05	5.95	70.01	6.50
16	NA	NA	69.61	6.47	75.85	7.05	75.85	7.05
20	NA	NA	90.30	8.39	97.35	9.04	104.61	9.72
24	NA	NA	118.16	10.98	126.17	11.72	134.39	12.48

Table 3C - 600 psi gate valves - insulated Surface Area, sf (sm) for four different insulation thicknesses								
NPS, in.	1 in.	25 mm	2 in.	51 mm	3 in.	76 mm	4 in.	102 mm
2	10.78	1.002	13.57	1.26	16.44	1.53	18.96	1.76
3	14.48	1.345	15.81	1.47	18.92	1.76	22.22	2.06
4	20.12	1.869	20.12	1.87	20.12	1.87	20.12	1.87
6	28.72	2.668	30.59	2.84	34.94	3.25	39.43	3.66
8	NA	NA	42.73	3.97	47.75	4.44	53.05	4.93
10	NA	NA	52.80	4.90	58.70	5.45	64.48	5.99
12	NA	NA	62.62	5.82	68.60	6.37	74.03	6.88
14	NA	NA	72.50	6.73	78.89	7.33	85.50	7.94
16	NA	NA	84.23	7.82	91.08	8.46	98.15	9.12
20	NA	NA	113.29	10.52	121.26	11.26	129.44	12.02
24	NA	NA	149.57	13.90	158.72	14.74	168.08	15.61

Table 3D - 900 psi gate valves - insulated Surface Area, sf (sm) for four different insulation thicknesses								
NPS, in.	1 in.	25 mm	2 in.	51 mm	3 in.	76 mm	4 in.	102 mm
2	15.38	1.429	18.56	1.72	21.96	2.04	25.55	2.37
3	18.91	1.757	22.46	2.09	26.20	2.43	30.18	2.80
4	23.01	2.138	26.87	2.50	30.91	2.87	35.12	3.26
6	35.23	3.273	39.86	3.70	44.66	4.15	49.74	4.62
8	NA	NA	47.86	4.45	53.13	4.94	58.70	5.45
10	NA	NA	59.39	5.52	65.32	6.07	71.48	6.64
12	NA	NA	72.94	6.78	79.51	7.39	86.30	8.02
14	NA	NA	86.00	7.99	93.11	8.65	93.11	8.65
16	NA	NA	102.21	9.49	109.88	10.21	117.78	10.94
20	NA	NA	NA	NA	NA	NA	NA	NA
24	NA	NA	NA	NA	NA	NA	NA	NA

6.2 *Estimation of Rate of Heat Loss from the Bare Surface*—Since Practice C680 needs to perform iterations in calculating heat flow across an insulation surface, an uninsulated surface must be simulated. To do this, select a thin insulation (with a thickness of 0.02 in. (0.5 mm)) and a thermal curve giving a high thermal conductivity. It is recommended that Type 1 be selected for which the following constants are assigned: $a = 10 \text{ Btu}\cdot\text{in.}/\text{h}\cdot\text{ft}^2\cdot\text{F}$ (1.44 W/m \cdot c), $b = 0$, and $c = 0$. 3E Plus has the capability of calculating heat loss from bare surfaces so this step is unnecessary.

6.2.1 Run Practice C680 or 3E Plus for either a horizontal or a vertical pipe of the appropriate diameter, inputting the ambient air temperature, wind speed, and bare valve surface emittance. Unless information is available for estimating the bare valve surface emittance, it is suggested that a value of 0.9

be selected. Select output in units of heat loss per unit surface area. This value of heat loss per unit bare surface area is designated q_B .

6.3 *Use of Practice C680 for the Insulated Valve or Flange*—Since Practice C680 is designed to calculate heat loss for insulated flat surfaces and for pipes, it is necessary to treat the insulated valve as an insulated pipe. It is recommended that the diameter of the pipe, to which the valve fits, or the diameter of the flanges be selected for the calculation. Input the same ambient air temperature and wind speed as in 6.1 and estimate the insulation surface emittance. For a removable insulation cover, this would be the emittance of the fabric or metal jacket. For conventional insulation, this is either the emittance of that