



Designation: D2509 – 14^{ε1}

Standard Test Method for Measurement of Load-Carrying Capacity of Lubricating Grease (Timken Method)¹

This standard is issued under the fixed designation D2509; the number immediately following the designation indicates the year of original adoption or, in the case of revision, the year of last revision. A number in parentheses indicates the year of last reapproval. A superscript epsilon (ϵ) indicates an editorial change since the last revision or reapproval.

^{ε1} NOTE—The IP designation was removed and footnote 1 was revised editorially in March 2017.

1. Scope*

1.1 This test method covers the determination of the load-carrying capacity of lubricating greases by means of the Timken Extreme Pressure Tester.

1.2 The values stated in SI units are to be regarded as the standard. The values given in parentheses are for information only.

1.3 *This standard does not purport to address all of the safety concerns, if any, associated with its use. It is the responsibility of the user of this standard to establish appropriate safety and health practices and determine the applicability of regulatory limitations prior to use.* For specific warning statements, see 7.1, 7.2, and 9.4.

2. Referenced Documents

2.1 ASTM Adjuncts:

Glossy Prints of Test Blocks Showing Various Types of Scar²

3. Terminology

3.1 Definitions:

3.1.1 *load-carrying capacity, of a lubricating grease, n*—the maximum load or pressure that can be sustained by a lubricating grease without failure of the sliding contact surfaces as evidenced by seizure or welding.

3.1.1.1 *Discussion*—The values of load carrying capacity of a lubricating grease vary according to test method.

3.1.2 *scoring, in tribology, n*—a severe form of wear characterized by the formation of extensive grooves and scratches in the direction of sliding.

3.1.2.1 *Discussion*—When the lubricant film is substantially maintained, a smooth scar is obtained on the test block, but when there is a breakdown of the lubricant film, scoring or surface failure of the test block takes place as shown in Fig. 1.² In its simplest and recognized form, scoring is characterized by a wide scar on the test block and by the transfer of metal from the test block to the contacting surface of the test cup. The form of surface failure more usually encountered, however, consists of a comparatively smooth scar, which shows local damage that usually extends beyond the width of the scar. Scratches or striations that occur in an otherwise smooth scar and that do not extend beyond the width of the scar are not considered scoring in this test method. The term scuffing is sometimes used as a synonym for scoring.

3.1.3 *seizure or welding, n*—localized fusion of rubbing metal, usually indicated by streaks of transferred metal, increased friction and wear, or unusual noise and vibration.

3.1.4 *wear, n*—the removal of metal from a rubbing surface by mechanical action, or by a combination of mechanical and chemical actions.

3.2 Definitions of Terms Specific to This Standard:

3.2.1 *OK value, n*—the maximum mass (weight) added to the load lever mass (weight) pan, at which no scoring or seizure occurs.

3.2.2 *score value, n*—the minimum mass (weight) added to the load lever mass (weight) pan, at which scoring or seizure occurs.

4. Summary of Test Method

4.1 The tester is operated with a steel test cup rotating against a steel test block. The rotational speed is 800 ± 5 r/min, which is equivalent to a linear speed of 123.71 ± 0.77 m/min (405.88 ± 2.54 ft/min). Grease samples are brought to and applied at $24 \pm 6^\circ\text{C}$ ($75 \pm 10^\circ\text{F}$).

4.2 Two determinations are made: the minimum load (score value) that will rupture the lubricant film being tested between the rotating cup and the stationary block and cause adhesion; and the maximum load (OK value) at which the rotating cup will not rupture the lubricant film and cause adhesion between the rotating cup and the stationary block.

¹ This test method is under the jurisdiction of ASTM Committee D02 on Petroleum Products, Liquid Fuels, and Lubricants and is the direct responsibility of Subcommittee D02.G0.04 on Functional Tests - Tribology.

Current edition approved Oct. 1, 2014. Published February 2015. Originally approved in 1966. Last previous edition approved in 2008 as D2509 – 03 (2008). DOI:10.1520/D2509-14E01.

² Available from ASTM International Headquarters. Order Adjunct No. ADJD2509. Original adjunct produced in 1972.

*A Summary of Changes section appears at the end of this standard

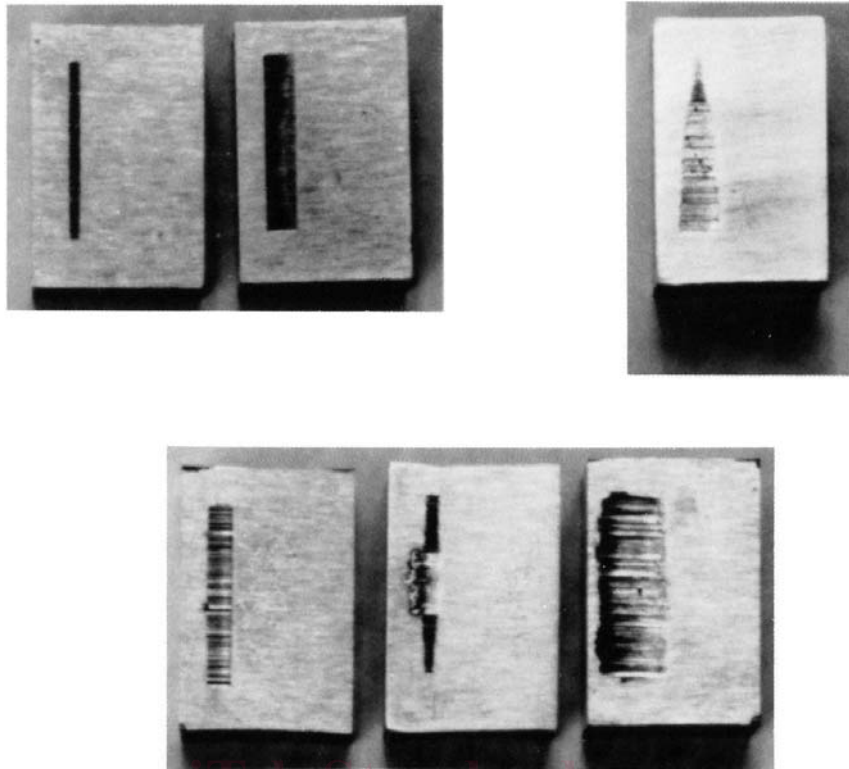

FIG. 1 Test Blocks Showing Various Types of Scar

5. Significance and Use

5.1 The test method is used widely for specification purposes and is used to differentiate between greases having low, medium, or high levels of extreme pressure characteristics. The results may not correlate with results from service.

6. Apparatus and Materials

6.1 *Timken Extreme Pressure Tester*, described in detail in **Annex A1** and illustrated in **Fig. 2**.

6.2 *Sample Feed Devices*, for supplying the test specimens with grease are described in **Annex A1**.

6.3 *Loading Mechanism*, for applying and removing the load mass (weight) without shock at the uniform rate 0.91 to 1.36 kg/s (2 to 3 lb/s). A detailed description is given in **Annex A1**.

6.4 *Test Cups*,^{3,4} of carburized steel, having a Rockwell Hardness C Scale Number of 58 to 62, or a Vickers Hardness Number of 653 to 746. The cups have a width of 13.06 ± 0.05 mm (0.514 ± 0.002 in.), a perimeter of 154.51 ± 0.23 mm (6.083 ± 0.009 in.), a diameter of $49.22 +0.025, -0.127$ mm ($1.938 +0.001, -0.005$ in.), and a maximum radial run-out of 0.013 mm (0.0005 in.). The axial surface roughness should lie between 0.51 and 0.76 μm (20 and 30 $\mu\text{in.}$) C.L.A.

³ The sole source of supply of the test cups known to the committee at this time is Falex Corporation, 1020 Airpark Dr., Sugar Grove, IL, 60554-9585 under Part No. F-25061.

⁴ If you are aware of alternative suppliers, please provide this information to ASTM International Headquarters. Your comments will receive careful consideration at a meeting of the responsible technical committee,¹ which you may attend.

6.5 *Test Blocks*^{4,5} with test surfaces 12.32 ± 0.10 mm (0.485 ± 0.004 in.) wide and 19.05 ± 0.41 mm (0.750 ± 0.016 in.) long, of carburized steel, having a Rockwell Hardness C Scale Number of 58 to 62, or a Vickers Hardness Number of 653 to 746. Each block is supplied with four ground faces and the surface roughness should lie between 0.51 and 0.76 μm (20 and 30 $\mu\text{in.}$) C.L.A.

6.6 *Microscope*,^{4,6} low-power (50 \times to 60 \times), having sufficient clearance under objective to accommodate the test block. It should be fitted with a filar micrometer so that the scar width may be measured with an accuracy of ± 0.05 mm (± 0.002 in.).

6.7 *Timer*, graduated in minutes and seconds.

7. Reagents

7.1 *Acetone*, reagent grade, minimum purity. (**Warning**—Extremely flammable. Vapors can cause flash fire.)

7.2 *Stoddard Solvent*, also known as Mineral Spirits, reagent grade. (**Warning**—Combustible. Vapor harmful.)

8. Preparation of Apparatus

8.1 Clean the apparatus with Stoddard solvent and acetone (see **7.1** and **7.2**), and blow dry. Shield the sump outlet and disconnect the oil pump to eliminate wear on the unused pump. Replace the oil reservoir with the grease feed device.

⁵ The sole source of supply of the test blocks known to the committee at this time is Falex Corporation, 1020 Airpark Dr., Sugar Grove, IL, 60554-9585 under Part No. F-25001.

⁶ The sole source of supply of the apparatus known to the committee at this time is Falex Corporation, 1020 Airpark Dr., Sugar Grove, IL, 60554-9585.

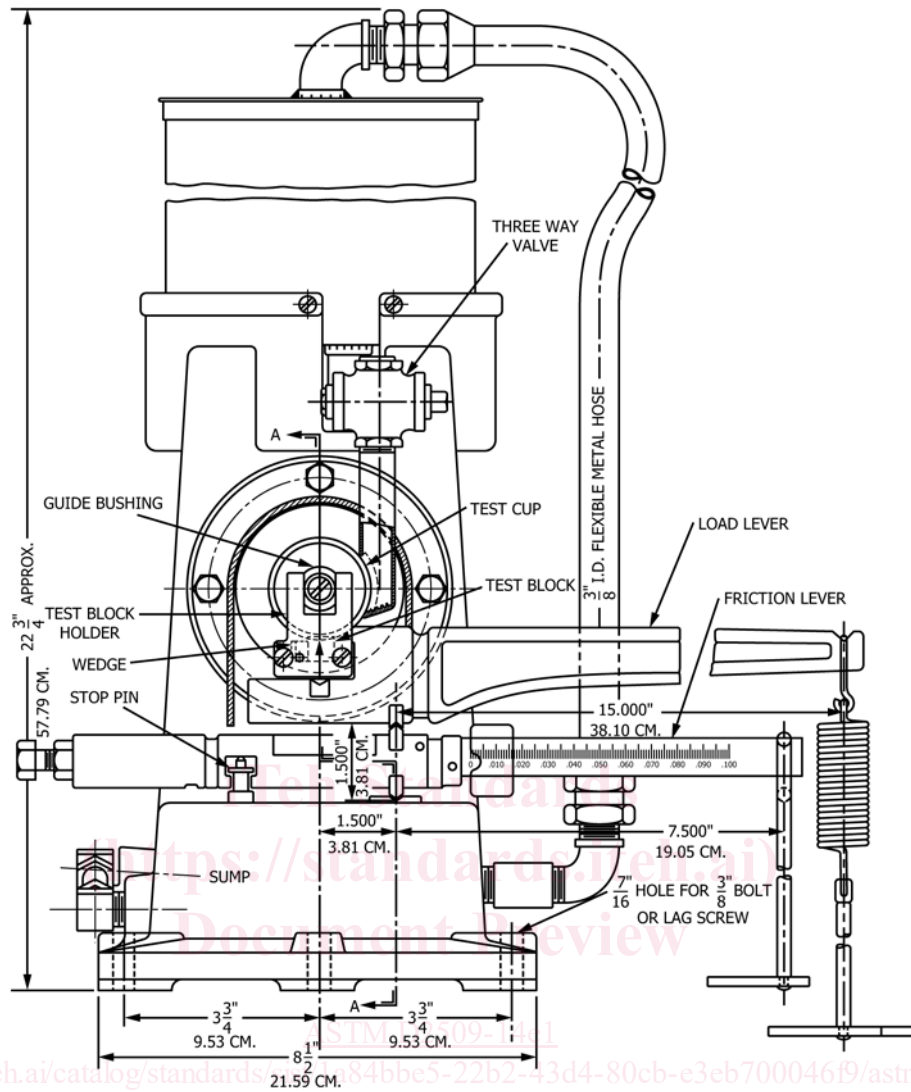

FIG. 2 Timken Tester

8.2 Select a new test cup and block, wash with Stoddard solvent, and dry with a clean soft cloth or paper. Immediately before use rinse the test cup and block with acetone and blow them dry. Do not use solvents such as carbon tetrachloride or others that may inherently possess load-carrying properties which may affect the results.

8.3 Assemble the tester carefully (Fig. 3), placing the test cup on the spindle and making certain that it is well seated, drawing it up firmly but avoiding possible distortion from excessive tightening (Note 1). Place the test block in the test block holder and adjust the levers so that all the knife edges are in proper alignment. Exercise special care in placing the stirrup of the spring-weight platform assembly (selection of which will depend on the loading device) in the groove of the load-lever arm to avoid premature shock to the test block when the load is applied. To ensure the test block, test block holder, and lever arms are properly aligned and seated, coat the test block and test cup with the grease to be tested, and rotate the machine slowly for a few revolutions either by hand or by

suitable control mechanism. If the parts are in alignment, the grease will be wiped off the cup over its entire width.

NOTE 1—At this point it is recommended that a dial indicator be used to check that the radial run-out of the cup *in situ* does not exceed 0.001 in. (0.025 mm) total indicator movement.

9. Procedure

9.1 Bring the grease to 24 ± 6°C (75 ± 10°F). Fill the grease-feeding device with grease, avoiding the inclusion of air bubbles. Apply a film of grease to the test cup and block and thoroughly grease the guide bushing with the test grease. Do not heat the grease.

9.2 Apply the grease at 24 ± 6°C (75 ± 10°F) to the test block through the grease-feed mechanism at the uniform rate of 45 ± 9 g/min (0.1 ± 0.02 lb/min). Start the motor and run for 30 s to break-in. If the equipment used is equipped with acceleration control, start the motor and gradually increase the rotational speed of the spindle to achieve 800 ± 5 rpm after 15 s. Run for a further 15 s to complete the break-in.

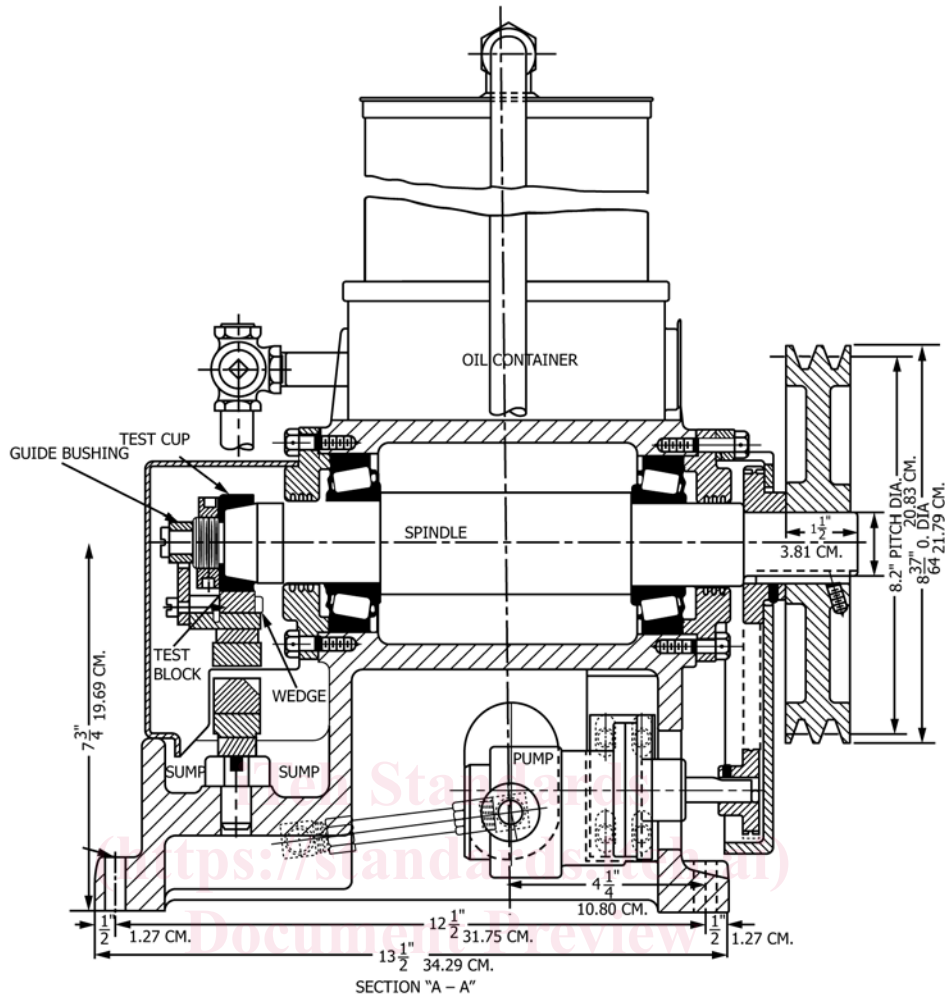

FIG. 2 Timken Tester (continued)

ASTM D2509-14e1

<https://standards.iteh.ai/catalog/standards/sist/1a84bbe5-23b2-43d4-80cb-e3eb700046f9/astm-d2509-14e1>

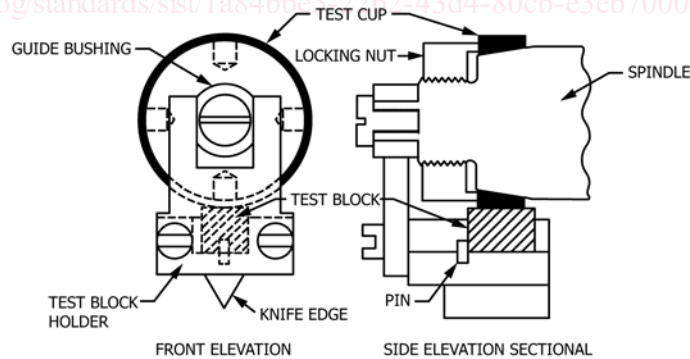

FIG. 3 Assembly of Tester Showing Test Pieces

9.3 After the break-in period of 30 s, start the timer and apply at 8.9 to 13.3 N/s (2 to 3 lbf/s), a load of 133.4 N (30 lbf). (A starting load of 133.4 N (30 lbf/s) is recommended. The load lever arm, spring, and mass (weight) carrier assembly are not considered part of the applied load.) Then allow the machine to run at 800 ± 5 rpm for 10 min \pm 15 s after load application is initiated, unless a score is detected before that period. Excessive noise and fluctuations in the spindle speed

indicate scoring of the test components. Stop the machine at once, turn off the supply of grease lubricant, and remove the load.

9.4 If, after the load has been applied, scoring is evident by vibration or noise, stop the tester at once, remove the load, and turn off the flow of lubricant. Since the excessive heat