



Designation: **E1786—08 E1786 – 17**

Standard Test Method for Determination of Low Levels of Water in Liquid Chlorine by On-Line Infrared Spectrophotometry¹

This standard is issued under the fixed designation E1786; the number immediately following the designation indicates the year of original adoption or, in the case of revision, the year of last revision. A number in parentheses indicates the year of last reapproval. A superscript epsilon (ϵ) indicates an editorial change since the last revision or reapproval.

1. Scope*

1.1 This test method is designed for the on-line determination of the content of water in liquid chlorine in the concentration range of 0.5 to 15 mg/kg (ppm).

1.2 The values stated in SI units are to be regarded as standard. The values given in parentheses are for information only.

1.3 Review the current Material–Safety Data Sheets (~~MSDS~~)(SDS) for detailed information concerning toxicity, first aid procedures, and safety precautions.

1.4 *This standard does not purport to address all of the safety concerns, if any, associated with its use. It is the responsibility of the user of this standard to establish appropriate safety and health practices and determine the applicability of regulatory limitations prior to use.* Specific hazards statements are given in Section 7 and **Note 3**.

2. Referenced Documents

2.1 *ASTM Standards:*²

D1193 Specification for Reagent Water

E806 Test Method for Carbon Tetrachloride and Chloroform in Liquid Chlorine by Direct Injection (Gas Chromatographic Procedure)

2.2 *Federal Standards:*³

49 CFR 173 Code of Federal Regulations Title 49 Transportation: ~~Shippers'~~ **Shippers'** General Requirements for Shipments and Packaging, including the following sections:

173.304 Charging of Cylinders with Liquefied Compressed Gas

173.314 Requirements for Compressed Gases in Tank Cars

173.315 Compressed Gases in Cargo Tanks and Portable Tank Containers

2.3 *Other Document:*⁴

Chlorine Institute Pamphlet No. 771 — Sampling Liquid Chlorine — Chlorine Basics

3. Summary of Test Method

3.1 Liquid chlorine continuously flows through a special infrared cell where it is maintained as a liquid under its own pressure. A process infrared spectrometer scans from 400 to 4400 wavenumbers of the infrared transmission spectrum of liquid chlorine. This spectrum then is ratioed to one obtained from the nitrogen-filled infrared cell previously. The ratioed spectrum is converted to absorbance, and the net absorbance of water band at 1596 wavenumbers, relative to a reference at 1663 wavenumbers, is determined.

3.2 The amount of water corresponding to this net absorbance is determined from a calibration curve prepared from the infrared absorbencies of standards which contain concentrations of water in liquid chlorine. These standards are prepared from manual

¹ This test method is under the jurisdiction of ASTM Committee **D16** on Aromatic Hydrocarbons and Related Chemicals and is the direct responsibility of Subcommittee **D16.16** on Industrial and Specialty Product Standards.

Current edition approved ~~April 1, 2008~~ **March 1, 2017**. Published ~~May 2008~~ **March 2017**. Originally approved in 1996. Last previous edition approved in ~~2002~~ **2008** as **E1786—02**; **E1786 – 08**. DOI: ~~10.1520/E1786-08~~ **10.1520/E1786-17**.

² For referenced ASTM standards, visit the ASTM website, www.astm.org, or contact ASTM Customer Service at service@astm.org. For *Annual Book of ASTM Standards* volume information, refer to the standard's Document Summary page on the ASTM website.

³ *Code of Federal Regulations*, available from U.S. Government Printing Office, Washington, DC 20402; Superintendent of Documents, 732 N. Capitol St., NW, Washington, DC 20401-0001, <http://www.access.gpo.gov>.

⁴ Available from The Chlorine Institute, Inc., 2001 L St. NW, Washington, DC 20036-4919; 1300 Wilson Blvd., Suite 525, Arlington, VA 22209, <https://www.chlorineinstitute.org>.

*A Summary of Changes section appears at the end of this standard

samples of liquid chlorine in tantalum cylinders. Sample from each cylinder is introduced into a calibration infrared cell and maintained as a liquid under its own pressure.

4. Significance and Use

4.1 Trace amounts of water may be detrimental to the use of chlorine in some applications. The amount of water in the chlorine must be known to prevent problems during its use.

5. Apparatus

5.1 *Process Infrared Spectrometer*, capable of measurements in the 1600 wavenumber region. An FTIR with four wavenumber resolution is the instrument of choice, but dispersive instruments also may be used to achieve similar results.

5.2 *Special Infrared Calibration Cell* (Fig. 1), as used for calibration. Neither cell size nor pathlength are critical to the analysis, but sensitivity and limit of detection are dependent on pathlength. The concentration range reported in the Section 1 is achievable with a 60-mm pathlength cell constructed with the following: Figs. 2-7

5.2.1 *Hastelloy C and 316 Stainless Steel Stock*, suitable for machining,

5.2.2 *Silver Chloride Windows*, 0.5 cm × 2.5 cm, and

5.2.3 *Perfluoroelastomer Sheet*, 0.762 mm (0.030 in.) thickness.

5.3 *Ball Valves*, Monel 6.35 mm (1/4-in.) valve with pipe and 6.35 mm (1/4-in.) tube ends.

5.4 *Needle Valves*, Nickel or Monel 6.35 mm (1/4-in.) valve with pipe and 6.35 mm (1/4-in.) tube ends.

5.5 *Sample Cylinder Assembly* (Fig. 8), consisting of:

5.5.1 *Sample Cylinder*, nickel, Monel, or tantalum, 400 to 1000-mL capacity, double-ended, with valves at each end, specially cleaned. Cylinders with both valves at one end and with a dip tube on one valve have been found to be satisfactory. Another option is to construct special cylinders containing a septum fitting on one end.

NOTE 1—A procedure for cleaning cylinders and valves, for use with liquid chlorine, is given in Test Method E806, Appendix X2–X2.

ITeH Standards
(<https://standards.iteh.ai>)

Document Preview

<https://standards.iteh.ai/catalog/standards/sist/337bc421e-4ad4-a697-d3e972bc2b3/astm-e1786-17>

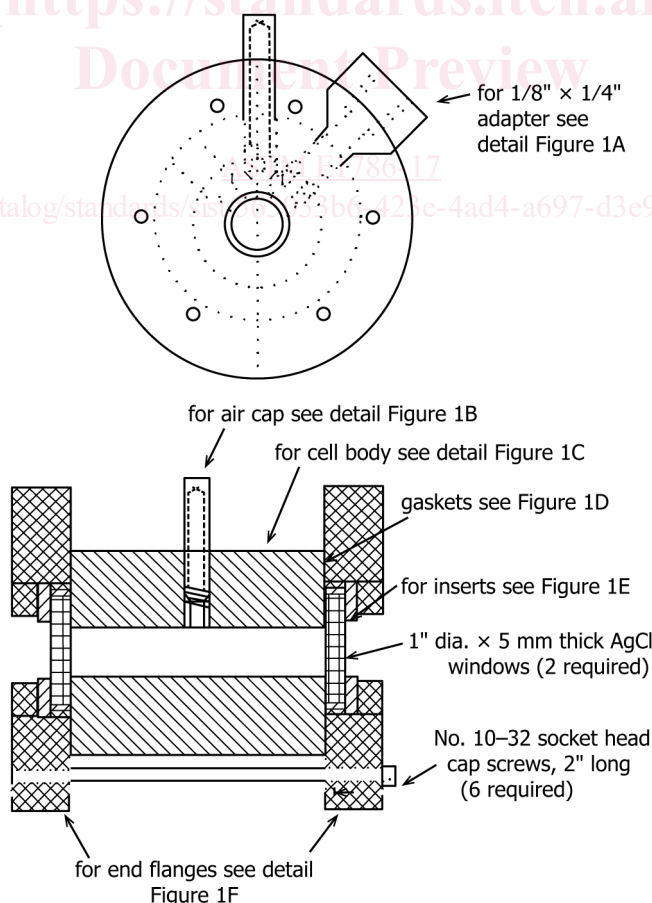
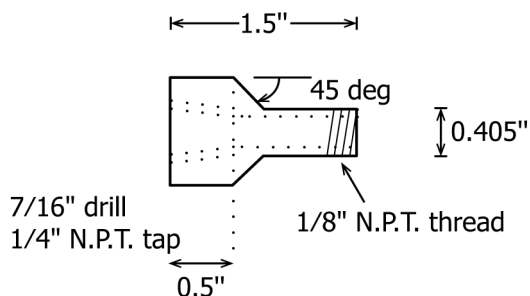
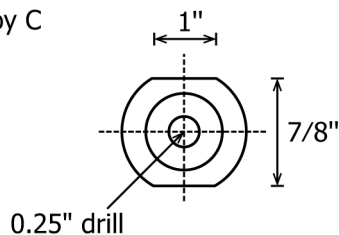

FIG. 1 Infrared Cell (Drawing Not to Scale)

1/8" x 1/4"
 material: Hastalloy C
 2 required



if desired, pipe adapters may be welded

FIG. 2 Pipe Adapter

(<https://standards.iteh.ai>)
 Document Preview

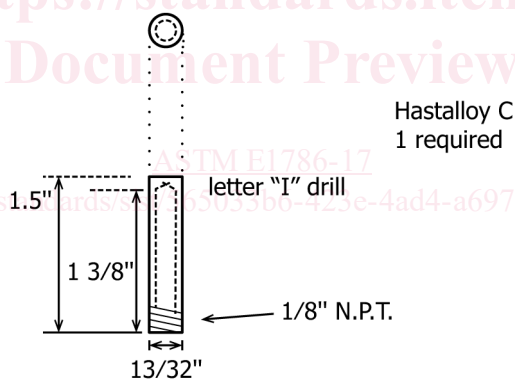

Hastalloy C
 1 required

FIG. 3 Air Cap Detail

5.5.2 *One Needle and One Ball Valve*, nickel body, having packing resistant to liquid chlorine. If nickel valves are not available, monel valves may be used.

5.5.3 *Septum*, inserted into a 6.35 mm (1/4-in.)-in. nut.

5.5.4 *Glove Bag or Dry Box*, purged with dry nitrogen (less than 5 mg/kg (ppm) water vapor).

5.5.5 *Fittings*, for transferring chlorine from one cylinder to another.

5.5.6 *One 0 to 10 µL Syringe and One 0 to 25 µL Syringe*, 26 gage needle.

5.5.7 *Dewar Flask*, of sufficient size to hold a cylinder surrounded by dry ice and methylene chloride. The Dewar flask should be supported by a wooden holder for safety purposes.

5.5.8 *Hygrometer*, capable of measuring moisture as low as 5 mg/kg (ppm) in glove bag or dry box.

5.6 *Silicone Rubber Septa*.

5.7 *Mechanical Shaker*.

5.8 *Drying Oven*.

Letter "R" drill 7/16" deep

Letter "I" drill thru
1/8" N.P.T. tap

3 holes as shown

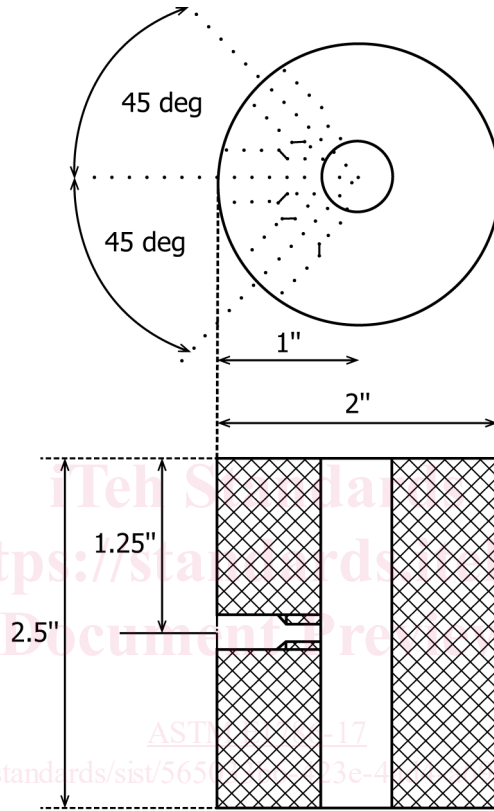
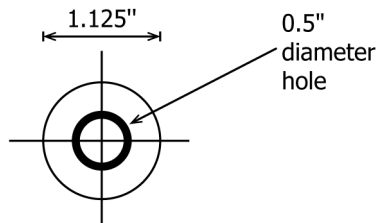

FIG. 4 Body Detail



DuPont Kalrez Perfluoroelastomer
2 required
material about 0.030" thick

FIG. 5 Gasket Detail

5.9 *Special Infrared Process Cell (Fig. 9)* for on-line analysis of water in liquid chlorine. Neither cell size nor path length is critical to the analysis, but sensitivity and limit of detection are dependent on pathlength. The concentration range reported in the scope is achievable with a 60-mm pathlength cell constructed with:

5.9.1 *Hastelloy C and 316 Stainless Steel Stock*, suitable for machining.

5.9.2 *Silver Chloride Windows*, two, 25-mm diameter by 2-mm thick and two 25-mm diameter by 4-mm thick.

5.9.3 *Eight Viton O-rings*, Size 027.

Material: Teflon
2 required

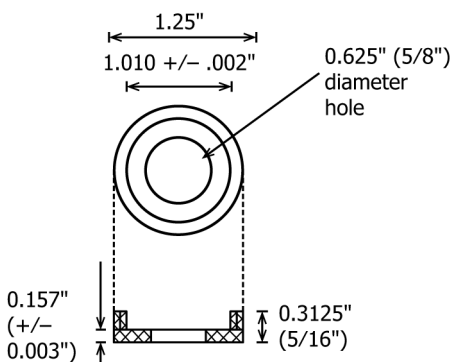

FIG. 6 Insert Detail

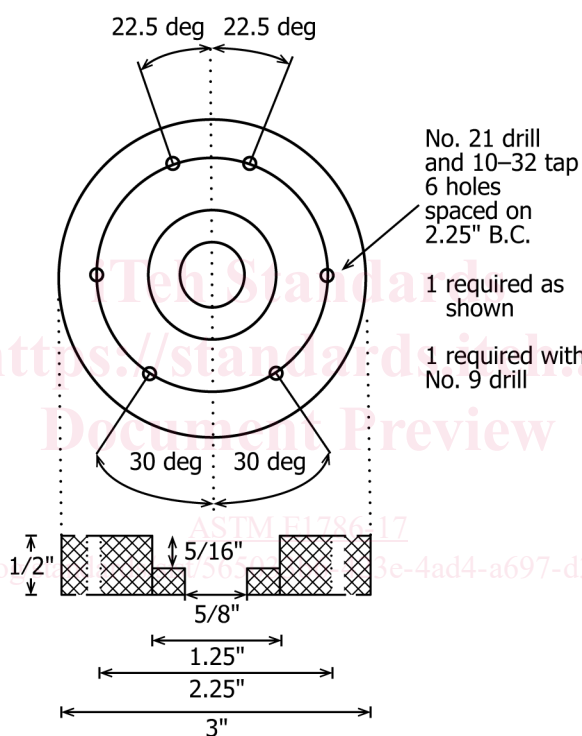

FIG. 7 Flange Detail

6. Reagents

6.1 *Purity of Water*—Unless otherwise indicated, water means Type II or III reagent water conforming to Specification **D1193**.

6.2 *Chlorine*, liquid with less than 5 mg/kg (ppm) water.

6.3 *Methylene Chloride* (CH₂Cl₂).

NOTE 2—This reagent is used for cooling purposes only.

6.4 *Dry Ice* (CO₂).

6.5 *Dry Nitrogen* (<5 mg/kg (ppm) water), to purge glove bag or dry box and test equipment.

7. Hazards

7.1 *Safety Precautions:*

7.1.1 Chlorine is a corrosive and toxic material. Use a well-ventilated fume hood to house all test equipment, except the infrared spectrophotometer, when this material is analyzed in the laboratory.

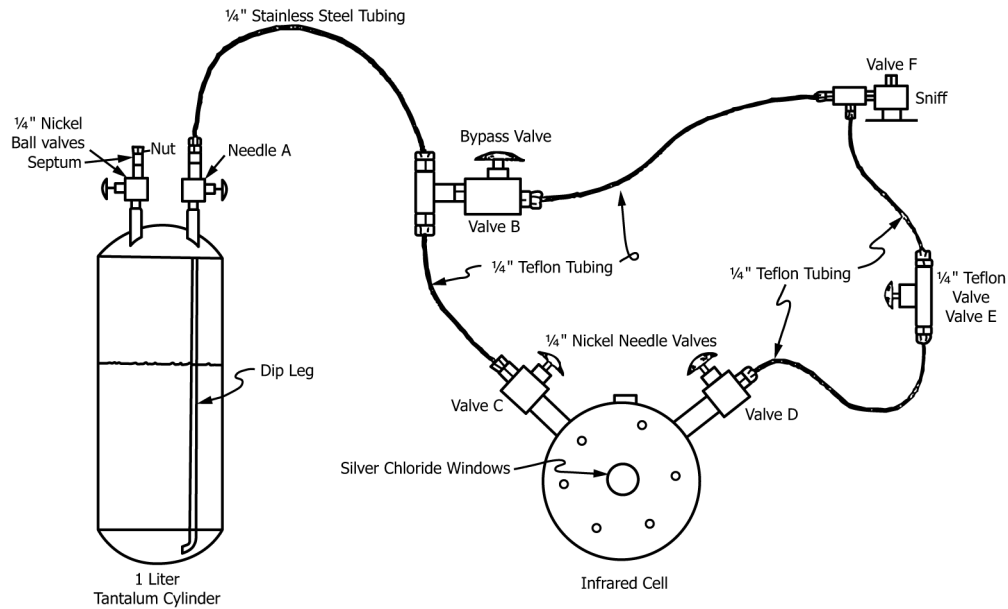

FIG. 8 Sample Cylinder Assembly

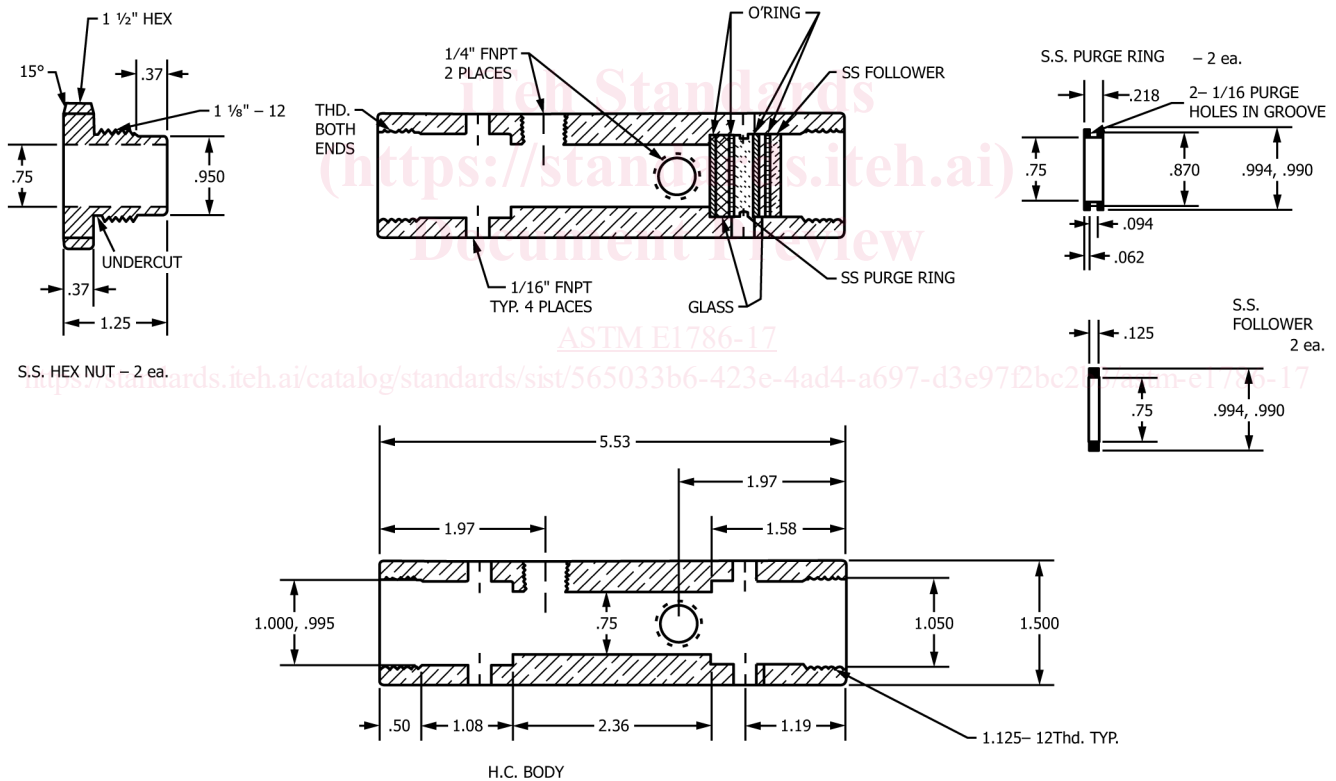

FIG. 9 Special Infrared Process Cell

7.1.2 Persons who are thoroughly familiar with the handling of chlorine should perform this analysis. An experienced person should not work alone. The analyst must be provided with adequate eye protection (chemical goggles are recommended) and an approved chlorine respirator. Splashes of liquid chlorine destroy clothing, and if such clothing is next to the skin, will produce irritation and burns.

7.1.3 When sampling and working with chlorine out of doors, warn people downwind from such operations of the possible release of chlorine.

7.1.4 Dispose of excess chlorine in an environmentally safe and acceptable manner. If chlorine cannot be disposed of in a chlorine consuming process, provide a chlorine absorption system. When the analysis and sampling regimen requires an initial purging of chlorine from a container, the purged chlorine should be similarly handled. Avoid purging to the atmosphere.