



## Designation: **F2180–02 (Reapproved 2015) F2180 – 17**

# Standard Specification for Metallic Implantable Strands and Cables<sup>1</sup>

This standard is issued under the fixed designation F2180; the number immediately following the designation indicates the year of original adoption or, in the case of revision, the year of last revision. A number in parentheses indicates the year of last reapproval. A superscript epsilon ( $\epsilon$ ) indicates an editorial change since the last revision or reapproval.

## 1. Scope

1.1 This specification covers the materials, dimensional tolerances, constructions, and mechanical properties for standard metallic implantable strands and cables.

1.2 This specification is intended to assist in the development of specific strand and cable specifications. It is particularly appropriate for high load bearing applications. It is not intended however, to address all of the possible variations in construction, material, or properties.

1.3 The values stated in SI units are to be regarded as standard. No other units of measurement are included in this standard.

1.4 *This international standard was developed in accordance with internationally recognized principles on standardization established in the Decision on Principles for the Development of International Standards, Guides and Recommendations issued by the World Trade Organization Technical Barriers to Trade (TBT) Committee.*

## 2. Referenced Documents

2.1 *ASTM Standards:*<sup>2</sup>

[E8 Test Methods for Tension Testing of Metallic Materials](#)

[F86 Practice for Surface Preparation and Marking of Metallic Surgical Implants](#)

[F90 Specification for Wrought Cobalt-20Chromium-15Tungsten-10Nickel Alloy for Surgical Implant Applications \(UNS R30605\)](#)

[F136 Specification for Wrought Titanium-6Aluminum-4Vanadium ELI \(Extra Low Interstitial\) Alloy for Surgical Implant Applications \(UNS R56401\)](#)

[F138 Specification for Wrought 18Chromium-14Nickel-2.5Molybdenum Stainless Steel Bar and Wire for Surgical Implants \(UNS S31673\)](#)

[F562 Specification for Wrought 35Cobalt-35Nickel-20Chromium-10Molybdenum Alloy for Surgical Implant Applications \(UNS R30035\)](#)

[F1058 Specification for Wrought 40Cobalt-20Chromium-16Iron-15Nickel-7Molybdenum Alloy Wire, Strip, and Strip Bar for Surgical Implant Applications \(UNS R30003 and UNS R30008\)](#)

[F1295 Specification for Wrought Titanium-6Aluminum-7Niobium Alloy for Surgical Implant Applications \(UNS R56700\)](#)

[F1314 Specification for Wrought Nitrogen Strengthened 22 Chromium–13 Nickel–5 Manganese–2.5 Molybdenum Stainless Steel Alloy Bar and Wire for Surgical Implants \(UNS S20910\)](#)

[F1341 Specification for Unalloyed Titanium Wire UNS R50250, UNS R50400, UNS R50550, UNS R50700, for Surgical Implant Applications \(Withdrawn 2006\)](#)<sup>3</sup>

[F2503 Practice for Marking Medical Devices and Other Items for Safety in the Magnetic Resonance Environment](#)

2.2 *American Society for Quality (ASQ) Standard: ISO Standards:*<sup>4</sup>

[ASQ-ISO 9001 Specification of General Requirements for a Quality Program Quality Management Systems—Requirements](#)

<sup>1</sup> This specification is under the jurisdiction of ASTM Committee F04 on Medical and Surgical Materials and Devices and is the direct responsibility of Subcommittee F04.21 on Osteosynthesis.

Current edition approved Sept. 1, 2015 Feb. 1, 2017. Published October 2015 March 2017. Originally approved in 2002. Last previous edition approved in 2011 as F2180 – 02 (2011) (2015).<sup>2</sup> DOI: 10.1520/F2180-02R15.10.1520/F2180-17.

<sup>2</sup> For referenced ASTM standards, visit the ASTM website, [www.astm.org](http://www.astm.org), or contact ASTM Customer Service at [service@astm.org](mailto:service@astm.org). For *Annual Book of ASTM Standards* volume information, refer to the standard's Document Summary page on the ASTM website.

<sup>3</sup> The last approved version of this historical standard is referenced on [www.astm.org](http://www.astm.org).

<sup>4</sup> Available from American Society for Quality (ASQ), 600 N. Plankinton Ave., Milwaukee, WI 53203, <http://www.asq.org>; National Standards Institute (ANSI), 25 W. 43rd St., 4th Floor, New York, NY 10036, <http://www.ansi.org>.

2.3 Department of Defense Specifications:<sup>5</sup>

- MIL-DTL-83420J Wire Rope, Flexible, For Aircraft Control
- MIL-DTL-83420/1B Wire Rope, Flexible, Type 1, Composition A
- MIL-DTL-83420/2B Wire Rope, Flexible, Type 1, Composition B

### 3. Terminology

3.1 Definitions:

3.1.1 *cable*, *n*—a group of strands helically twisted together.

3.1.2 *diameter*, *n*—the distance between opposing points across the circle circumscribing either the strand or cable as illustrated in Figs. 1 and 2 (see MIL-DTL-83420J, MIL-DTL-83420/1B and MIL-DTL-83420/2B).

3.1.3 *lay (or twist)*, *n*—the helical form taken by the wires in a strand and by the strands in a cable (see MIL-DTL-83420J).

<sup>5</sup> Available from DODSSP, Building 4, Section D, 700 Robbins Ave., Philadelphia, PA 19111-5098.

3.1.3.1 Discussion—

In a “Right Lay” situation, the wires of the strand (or the strands in a cable) are oriented in the same direction as the thread on a right-hand screw.

3.1.4 *length of lay (or pitch)*, *n*—the distance parallel to the axis of the strand (or cable) in which a wire (or strand) makes one complete turn about the axis.

3.1.5 *M×N*, *n*—the construction designation for strands and cables. In this construction designation *M* represents the number of strands in the cable and *N* represents the number of wires in each strand.

3.1.5.1 Discussion—

Some examples of strand constructions are 1×7 and 1×3. Similar examples of cable constructions are 7×7 and 7×19.

3.1.6 *strand*, *n*—a group of wires helically twisted together.

3.1.7 *wire*, *n*—an individual element (typically a cylindrical rod) making up a strand.

### 4. General Requirements

4.1 In addition to the requirements of this specification, all requirements of the current editions of Specifications F90, F136, F138, F562, F1058, F1295, F1314, and F1341 shall apply.

4.2 In cases of conflict between this specification and those listed in 2.1, this specification shall take precedence.

### 5. Ordering Information

5.1 Inquiries and orders under this specification shall include the following information:

- 5.1.1 Quantity (weight, length, or number of pieces),
- 5.1.2 ASTM designation,
- 5.1.3 Material (ASTM designation),

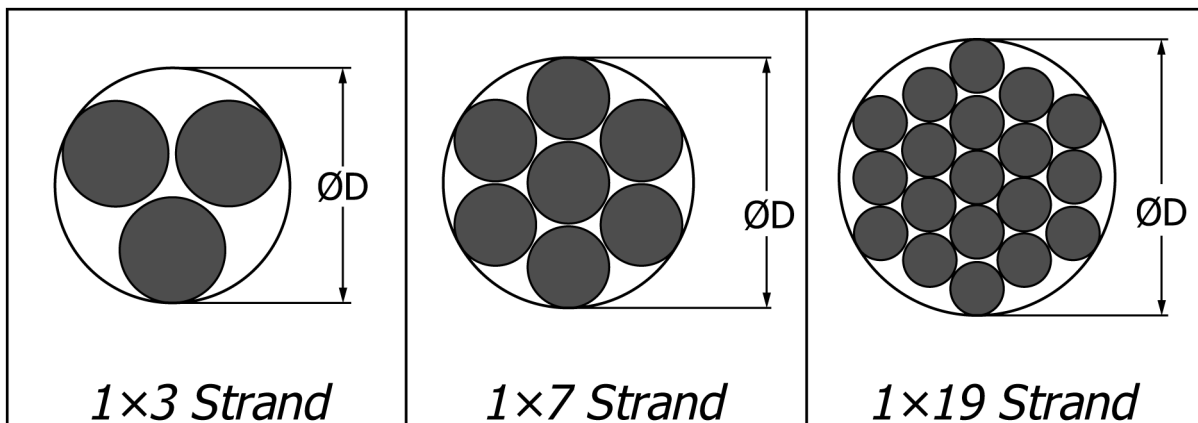

FIG. 1 Standard Stranding Constructions