



Designation: **D2937–17** **D2937 – 17^{ε1}**

Standard Test Method for Density of Soil in Place by the Drive-Cylinder Method¹

This standard is issued under the fixed designation D2937; the number immediately following the designation indicates the year of original adoption or, in the case of revision, the year of last revision. A number in parentheses indicates the year of last reappraisal. A superscript epsilon (ϵ) indicates an editorial change since the last revision or reappraisal.

This standard has been approved for use by agencies of the U.S. Department of Defense.

^{ε1} NOTE—Editorially corrected Example Data Sheet in [Appendix X1](#) in April 2017.

1. Scope*

1.1 This test method covers the determination of in-place density of soil by the drive-cylinder method. The test method involves obtaining an intact soil sample by driving a thin-walled cylinder into the soil and conducting specific measurements and calculations for the determination of in-place density. When sampling or in-place density is required at depth, Test Method **D1587** should be used.

1.2 This test method is not recommended for sampling organic or friable soils which may compress during sampling. This test method may not be applicable for soft, organic, highly plastic, noncohesive, saturated or other soils which are easily deformed, compress during sampling, or which may not be retained in the drive cylinder sampler. This test may not be applicable with very hard natural soils or heavily compacted soils that may not be easily penetrated with the drive cylinder sampler. The use of this test method in soils containing an appreciable amount of particles larger than 4.75 mm ($\frac{3}{16}$ in.) may result in damage to the drive cylinder equipment. Soils containing particles larger than 4.75 mm ($\frac{3}{16}$ in.) may not yield valid results if voids are created along the wall of the cylinder during driving, or if particles are dislodged from the sample ends during trimming.

1.3 This test method is limited to the procedures necessary for obtaining specimens suitable for determining the in-place density and water content of certain soils. The procedures, precautions, and requirements necessary for selecting locations for obtaining intact samples, suitable for laboratory testing or otherwise determining engineering properties, is beyond the scope of this test method.

1.4 The values stated in SI units are to be regarded as standard. The inch-pound units given in parentheses are mathematical conversions, which are provided for information purposes only and are not considered standard.

1.4.1 It is common practice in the engineering/construction profession to concurrently use pounds to represent both a unit of mass (lbm) and a unit of force (lbf). This implicitly combines two separate systems of units; that is, the absolute system and the gravitational system. It is scientifically undesirable to combine the use of two separate sets of inch-pound units within a single standard. As stated, this standard includes the gravitational system of inch-pound units and does not use/present the slug unit for mass. However, the use of balances or scales recording pounds of mass (lbm) or the recording of density in lbm/ft^3 shall not be regarded as nonconformance with this standard.

1.5 All observed and calculated values shall conform to the guidelines for significant digits and rounding established in Practice **D6026**, unless superseded by this standard.

1.5.1 The procedures used to specify how data are collected/recorded or calculated in this standard are regarded as the industry standard. In addition, they are representative of the significant digits that generally should be retained. The procedures used do not consider material variation, purpose for obtaining the data, special purpose studies, or any considerations for the user's objectives; and it is common practice to increase or reduce significant digits of reported data to be commensurate with these considerations. It is beyond the scope of this standard to consider significant digits used in analysis methods for engineering design.

1.6 *This standard does not purport to address all of the safety concerns, if any, associated with its use. It is the responsibility of the user of this standard to establish appropriate safety and health practices and determine the applicability of regulatory limitations prior to use.*

¹ This test method is under the jurisdiction of ASTM Committee **D18** on Soil and Rock and is the direct responsibility of Subcommittee **D18.08** on Special and Construction Control Tests.

Current edition approved Feb. 1, 2017. Published February 2017. Originally approved in 1971. Last previous edition approved in 2010 as D2937 – 10. DOI: [10.1520/D2937-17](#); [10.1520/D2937-17E01](#).

*A Summary of Changes section appears at the end of this standard

1.7 This international standard was developed in accordance with internationally recognized principles on standardization established in the Decision on Principles for the Development of International Standards, Guides and Recommendations issued by the World Trade Organization Technical Barriers to Trade (TBT) Committee.

2. Referenced Documents

2.1 ASTM Standards:²

D653 Terminology Relating to Soil, Rock, and Contained Fluids

D698 Test Methods for Laboratory Compaction Characteristics of Soil Using Standard Effort (12,400 ft-lbf/ft³ (600 kN-m/m³))

D1557 Test Methods for Laboratory Compaction Characteristics of Soil Using Modified Effort (56,000 ft-lbf/ft³ (2,700 kN-m/m³))

D1587 Practice for Thin-Walled Tube Sampling of Fine-Grained Soils for Geotechnical Purposes

D2216 Test Methods for Laboratory Determination of Water (Moisture) Content of Soil and Rock by Mass

D2488 Practice for Description and Identification of Soils (Visual-Manual Procedure)

D3740 Practice for Minimum Requirements for Agencies Engaged in Testing and/or Inspection of Soil and Rock as Used in Engineering Design and Construction

D4643 Test Method for Determination of Water Content of Soil and Rock by Microwave Oven Heating

D4753 Guide for Evaluating, Selecting, and Specifying Balances and Standard Masses for Use in Soil, Rock, and Construction Materials Testing

D4944 Test Method for Field Determination of Water (Moisture) Content of Soil by the Calcium Carbide Gas Pressure Tester

D4959 Test Method for Determination of Water Content of Soil By Direct Heating

D6026 Practice for Using Significant Digits in Geotechnical Data

3. Terminology

3.1 *Definitions*—For common terms found in this standard refer to Terminology **D653**.

4. Significance and Use

4.1 This test method can be used to determine the in-place density of soils which do not contain significant amounts of particles larger than 4.75 mm (³/₁₆ in.), and which can be readily retained in the drive cylinder. This test method may also be used to determine the in-place density of compacted soils used in construction of structural fill, highway embankments, or earth dams. When the in-place density is to be used as a basis for acceptance, the drive cylinder volumes must be as large as practical and not less than 850 cm³ (0.030 ft³).

4.2 The general principles of this test method have been successfully used to obtain samples of various field compacted fine-grained soils having a maximum particle size of 4.75 mm (³/₁₆ in.) for purposes other than density determinations, such as testing for engineering properties.

NOTE 1—Notwithstanding the statements on precision and bias contained in this standard: The precision of this test method is dependent on the competence of the personnel performing it and the suitability of the equipment and facilities used. Agencies which meet the criteria of Practice **D3740** are generally considered capable of competent and objective testing. Users of this method are cautioned that compliance with Practice **D3740** does not in itself assure reliable testing. Reliable testing depends on many factors; Practice **D3740** provides a means of evaluating some of those factors.

5. Apparatus

5.1 *Drive Cylinders*, of approximately 100 to 152 mm (4.00 to 6.00 in.) diameter. Larger sizes may be used if desired or required. Typical details of drive cylinders with outside diameters of 100 mm (4.00 in.) are shown in **Fig. 1** (see also **Table 1**). Drive cylinders of other diameters will require proportional changes in the drive-cylinder tube and drive-head dimensions. The volume of the cylinders with the dimensions shown in **Fig. 1** is approximately 940 cm³ (0.033 ft³). The apparatus shown in **Fig. 1** is of a design suitable for use at or near the surface.

5.1.1 When the in-place density is to be used as a basis for acceptance of compacted fill, the drive cylinders shall be as large as practical to reduce the effects of errors and shall be equal to or greater than 850 cm³ (0.030 ft³).

5.1.2 The number of drive cylinders required will depend on the number of samples to be taken and the anticipated rapidity by which the cylinders can be returned to service after processing.

5.1.3 The cylinders shown in **Fig. 1** meet the clearance ratio, wall thickness and area-ratio requirements as set forth by Hvorslev³ for drive cylinder samplers, and shall not exceed 10 to 15 %, as defined by the following:

$$A_r = [(D_w^2 - D_e^2)/D_e^2] \times 100 \quad (1)$$

² For referenced ASTM standards, visit the ASTM website, www.astm.org, or contact ASTM Customer Service at service@astm.org. For *Annual Book of ASTM Standards* volume information, refer to the standard's Document Summary page on the ASTM website.

³ Hvorslev, M. J., "Surface Exploration and Sampling of Soils for Engineering Purposes," Engineering Foundation, 345 E. 47th St., New York, NY 10017.

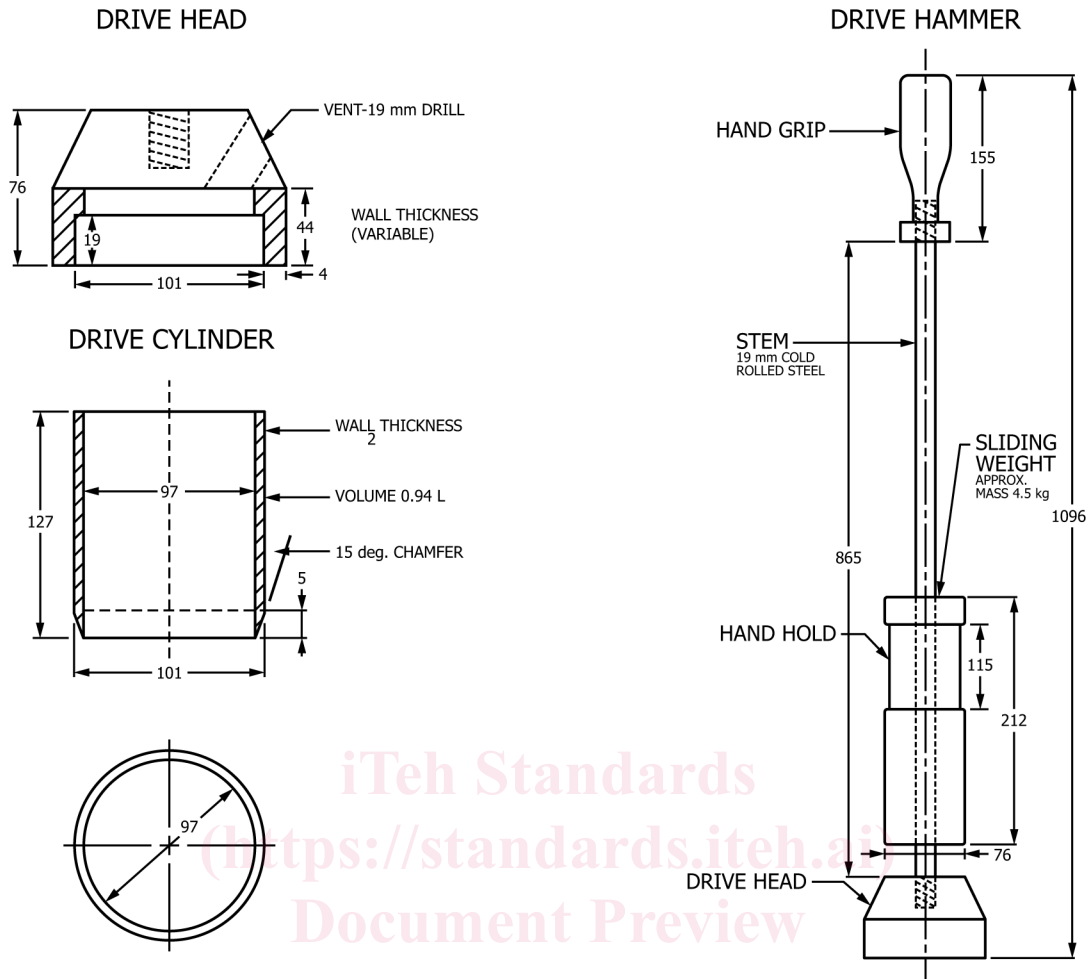

All length dimensions are in millimeters.

FIG. 1 Typical Design for a Surface Soil Sampler

TABLE 1 Dimensional Equivalent for Fig. 1

mm	in.	mm	in.
2	5/64	103	4 1/16
4	5/32	115	4 1/2
5	3/16	127	5.00
19	3/4	155	6.00
44	1 3/4	212	8.00
76	3.0	865	36.00
98	3 7/8	1096	45.00
100	4.00		

where:

A_r = area ratio, %,

D_w = maximum external diameter of the drive cylinder, and

D_e = effective (minimum) internal diameter of the drive sampler at the cutting edge after swaging.

5.1.4 Except for very short drive cylinder samplers with no clearance, the inside clearance ratio of the drive cylinders shall be from 0.5 to 3.0 %, with increasing ratios as the plasticity increases in the soil being sampled. Inside clearance ratio is defined by the following:

$$C_r = \frac{D_i - D_e}{D_e} \times 100 \quad (2)$$

where:

C_r = inside clearance ratio, %

D_e = effective (minimum) internal diameter of the sampler at the cutting edge after swaging, and
 D_i = internal diameter of the sampler.

5.1.5 Drive cylinders of other diameters shall conform to these requirements.

5.2 *Drive Head*—The typical details of the drive head and appurtenances are shown in Fig. 1. The drive head has a sliding weight for driving the cylinder.

5.3 *Straightedge*—Steel, approximately 3 mm (1/8 in.) by 38 mm (1 1/2 in.) by 305 mm (12.0 in.) with one edge sharpened at approximately a 45° angle for trimming the ends of the sample flush with the cylinder.

5.4 *Shovel*—Any one of several types of shovels or spades is satisfactory in shallow sampling for digging the cylinders out after they have been driven into the soil.

5.5 *Balance*—A balance having a minimum capacity of 10 kg (22 lbs) and meeting the requirements of Specification D4753 for a balance of 1 g (0.002 lbs) readability is required for the cylinders shown in Fig. 1. Larger cylinders will require a balance of 25 kg (55 lbs) capacity with readability of 1 gm (0.002 lbs).

5.6 *Drying Equipment*—Equipment or ovens, or both, to dry specimens, facilitating the determination of water (moisture) content in accordance with Test Methods D2216, D4643, D4944, or D4959.

5.7 *Miscellaneous Equipment*—Brushes, sledgehammers, plastic bags, metal cans with lids, or other suitable containers for retaining the drive cylinder and sample until the determination of moist mass and water content can be determined. Spoons, inside/outside caliper, or equivalent, accurate to 0.25 mm (0.01 in.) for calibration.

5.8 *Safety Equipment*—Gloves and safety glasses. Steel-toed shoes or boots if required by agency.

6. Procedure

6.1 Brush all loose particles from the surface. For near-surface sampling (not more than 1 m (3 ft) in depth), sample through a hole bored with an auger or dug by a shovel from which loosened material has been removed. The surface where the cylinder initially is placed should be fairly level prior to the cylinder being driven. Depending on the soil type and moisture condition, the surface may be prepared utilizing a bulldozer blade or other heavy equipment blades providing the sample area and vicinity are not deformed, compressed, torn, or otherwise disturbed.

6.2 Assemble the cylinder and drive apparatus with the sharpened edge on the surface to be sampled. Drive the cylinder by raising the drop hammer and allowing it to fall, or alternatively by applying a uniform force via a jack or similar device, while keeping the drive rod steady and in a vertical position. Continue driving until the top of the cylinder is approximately 13 mm (1/2 in.) below the original surface as shown in Fig. 2. Overdriving may result in deforming or compressing the sample and may influence the test results. Care shall be exercised to prevent overdriving, particularly when sampling below the surface. If overdriving occurs or is suspected, the sample shall be discarded and the soil resampled. Remove the drive head and remove the cylinder from the ground with a shovel; dig the soil from around the sides of the cylinder, undercutting several inches below the bottom of the cylinder before lifting the cylinder out from the ground. When sampling near the surface, more soil may need to be removed from around the sides of the cylinder to properly undercut the cylinder.

6.3 After the cylinder has been removed from the ground, remove any excess soil from the sides of the drive cylinder. Using the straightedge, trim the ends of the sample flush and plane with the ends of the cylinder. Patch with loose soil any voids that may have been created from the trimming process. A satisfactory sample consists of an intact soil sample and shall not contain rocks, roots, or other foreign material. If the drive cylinder is not full or does not properly represent the in-situ soil, discard the soil and obtain another sample. If the drive cylinder is deformed or otherwise damaged as a result of driving it into or removing

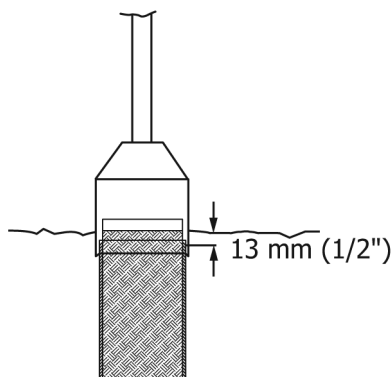

FIG. 2 Relationship of Driven Cylinder to Ground Surface