



Designation: D2172/D2172M – 17

Standard Test Methods for Quantitative Extraction of Asphalt Binder from Asphalt Mixtures¹

This standard is issued under the fixed designation D2172/D2172M; the number immediately following the designation indicates the year of original adoption or, in the case of revision, the year of last revision. A number in parentheses indicates the year of last reapproval. A superscript epsilon (ϵ) indicates an editorial change since the last revision or reapproval.

1. Scope

1.1 These test methods cover the quantitative determination of asphalt binder content in asphalt mixtures and pavement samples. Aggregate obtained by these methods may be used for sieve analysis using Test Method D5444. This test is not appropriate for testing asphalt mixtures containing coal tar.

1.2 Asphalt binder may be recovered using Test Method D1856, Practice D5404/D5404M, or Practice D7906.

1.3 *Units* – The values stated in either SI units or inch-pound units are to be regarded separately as standard. The values stated in each system may not be exact equivalents; therefore, each system shall be used independently of the other. Combining values from the two systems may result in nonconformance with the standard.

1.4 The text of this standard references notes and footnotes which provide explanatory material. These notes and footnotes (excluding those in tables and figures) shall not be considered as requirements of the standard.

1.5 *This standard does not purport to address all of the safety concerns, if any, associated with its use. It is the responsibility of the user of this standard to establish appropriate safety and health practices and determine the applicability of regulatory limitations prior to use.* Specific hazards are given in Section 7.

NOTE 1—The results obtained by these test methods may be affected by the age of the material tested, with older samples tending to yield slightly lower asphalt binder content. Best quantitative results are obtained when the test is made on mixtures and pavements shortly after their preparation. It is difficult to remove all the asphalt when some aggregates are used and some chlorides may remain within the mineral matter affecting the measured asphalt content.

1.6 *This international standard was developed in accordance with internationally recognized principles on standardization established in the Decision on Principles for the Development of International Standards, Guides and Recom-*

mendations issued by the World Trade Organization Technical Barriers to Trade (TBT) Committee.

2. Referenced Documents

2.1 ASTM Standards:²

- C128 Test Method for Relative Density (Specific Gravity) and Absorption of Fine Aggregate
- C670 Practice for Preparing Precision and Bias Statements for Test Methods for Construction Materials
- D70 Test Method for Density of Semi-Solid Bituminous Materials (Pycnometer Method)
- D604 Specification for Diatomaceous Silica Pigment (Withdrawn 2003)³
- D979/D979M Practice for Sampling Bituminous Paving Mixtures
- D1461 Test Method for Moisture or Volatile Distillates in Bituminous Paving Mixtures
- D1856 Test Method for Recovery of Asphalt From Solution by Abson Method
- D2111 Test Methods for Specific Gravity and Density of Halogenated Organic Solvents and Their Admixtures
- D3666 Specification for Minimum Requirements for Agencies Testing and Inspecting Road and Paving Materials
- D4753 Guide for Evaluating, Selecting, and Specifying Balances and Standard Masses for Use in Soil, Rock, and Construction Materials Testing
- D5404/D5404M Practice for Recovery of Asphalt from Solution Using the Rotary Evaporator
- D5444 Test Method for Mechanical Size Analysis of Extracted Aggregate
- D6368 Specification for Vapor-Degreasing Solvents Based on *normal*-Propyl Bromide and Technical Grade *normal*-Propyl Bromide
- D7906 Practice for Recovery of Asphalt from Solution Using Toluene and the Rotary Evaporator

¹ These test methods are under the jurisdiction of ASTM Committee D04 on Road and Paving Materials and are the direct responsibilities of Subcommittee D04.25 on Analysis of Asphalt Mixtures.

Current edition approved April 1, 2017. Published April 2017. Originally approved in 1963. Last previous edition approved in 2011 as D2172/D2172M – 11. DOI: 10.1520/D2172_D2172M-17.

² For referenced ASTM standards, visit the ASTM website, www.astm.org, or contact ASTM Customer Service at service@astm.org. For *Annual Book of ASTM Standards* volume information, refer to the standard's Document Summary page on the ASTM website.

³ The last approved version of this historical standard is referenced on www.astm.org.

2.2 AASHTO Standards:

R47 Practice for Reducing Samples of Hot Mix Asphalt (HMA) to Testing Size⁴

3. Summary of Test Methods

3.1 The asphalt mixture is extracted with trichloroethylene (TCE), normal propyl bromide (nPB), or methylene chloride using the extraction equipment applicable to the particular method. The asphalt binder content is calculated by difference from the mass of the extracted aggregate, moisture content, if determined, and mineral matter in the effluent (binder-solvent solution). The asphalt binder content is expressed as mass percent of moisture-free mixtures.

4. Significance and Use

4.1 All of these test methods can be used for quantitative determinations of asphalt binder in asphalt mixtures and pavement samples for specification acceptance, service evaluation, control, and research. Each method prescribes the solvent or solvents and any other reagents that can be used in the test method.

NOTE 2—Further testing of the asphalt mixture may be performed by using sieve analysis on the extracted aggregate, Test Method **D5444**, or recovering the extracted asphalt binder from solution by Test Method **D1856**, Practice **D5404/D5404M**, or Practice **D7906** for asphalt binder property testing. When recovering the asphalt binder for property testing, all mineral matter should be removed from the effluent.

NOTE 3—The quality of the results produced by this standard are dependent on the competence of the personnel performing the procedure and the capability, calibration, and maintenance of the equipment used. Agencies that meet the criteria of Specification **D3666** are generally considered capable of competent and objective testing/sampling/inspection, etc. Users of this standard are cautioned that compliance with Specification **D3666** alone does not completely ensure reliable results. Reliable results depend on many factors; following the suggestions of Specification **D3666** or some similar acceptable guideline provides a means of evaluating and controlling some of those factors.

5. Apparatus

5.1 *Oven*, capable of maintaining the temperature at 110 ± 5 °C [230 ± 9 °F].

5.2 *Pan*, large enough that the asphalt mixture can be spread out in a thin layer over the bottom of the pan.

5.3 *Balance*, readable to 0.1 g, and capable of measuring the mass of sample and container. The balance shall conform to the requirement of Guide **D4753**, Class GP2.

5.4 *Analytical Balance*, readable to 0.001 g and capable of measuring the mass of the sample and container.

5.5 *Electric Hot Plate*, thermostatically controlled, of sufficient dimensions and heat capacity to permit evaporating or refluxing of the solvent.

5.6 *Small-Mouth Graduate Container*, 1000- or 2000-mL capacity. Optional small-mouth graduate, 100-mL capacity.

5.7 *Ignition Dish*, 125-mL capacity.

⁴ Available from American Association of State Highway and Transportation Officials (AASHTO), 444 N. Capitol St., NW, Suite 249, Washington, DC 20001, <http://www.transportation.org>.

5.8 *Desiccator*, a container with a lid of sufficient size to hold the ignition dish on a perforated drying rack above the top level of the desiccant. The lid should form a good seal around the top of the container so that air movement between the container and the atmosphere is prevented

6. Reagents

6.1 *Purity of Reagents*—Reagent grade chemicals shall be used in all tests. Unless otherwise indicated, it is intended that all reagents shall conform to the specifications of the Committee on Analytical Reagents of the American Chemical Society,⁵ where such specifications are available. Other grades may be used, provided it is first ascertained that the reagent is of sufficiently high purity to permit its use without lessening the accuracy of the determination.

NOTE 4—Reagents that have exceeded the expiration date should not be used for asphalt mixtures that require asphalt binder property testing. The use of expired solvents may adversely affect the results of asphalt binder property testing.

6.2 Not all solvents (reagents) are applicable to all of the extraction methods detailed in this standard. Each extraction method identifies the specific solvents that can be used.

6.3 *Ammonium Carbonate Solution*—Saturated solution of reagent grade ammonium carbonate $[(\text{NH}_4)_2\text{CO}_3]$.

6.4 *normal-Propyl Bromide (nPB)*, conforming to Specification **D6368**. **Warning**—See Section 7.

6.5 *Toluene*, reagent grade. **Warning**—See Section 7.

6.6 *Trichloroethylene (TCE)*, technical grade, Type 1, Federal Specification O-T-634, latest revision. **Warning**—See Section 7.

6.7 *Methylene Chloride*, reagent grade. **Warning**—See Section 7.

6.8 *Diatomaceous Silica Filtering Aid*, conforming to Type B of Specification **D604**.

6.9 *Ethyl Alcohol*, denatured.

7. Hazards

7.1 **Warning**—The solvents listed in Section 6 should be used only under a hood or with an effective surface exhaust system in a well-ventilated area, since they are toxic to various degrees. Consult the current Threshold Limit Concentration Committee of the American Conference of Governmental Industrial Hygienists⁶ for the current threshold limit values.

8. Sampling

8.1 Obtain samples in accordance with Practice **D979/D979M**.

⁵ *Reagent Chemicals, American Chemical Society Specifications*, American Chemical Society, Washington, DC. For suggestions on the testing of reagents not listed by the American Chemical Society, see *Analar Standards for Laboratory Chemicals*, BDH Ltd., Poole, Dorset, U.K., and the *United States Pharmacopeia and National Formulary*, U.S. Pharmacopeial Convention, Inc. (USPC), Rockville, MD.

⁶ Available from American Conference of Governmental Industrial Hygienists (ACGIH), 1330 Kemper Meadow Dr., Cincinnati, OH 45240, <http://www.acgih.org>.

8.2 Preparation of Test Specimens:

8.2.1 Separate sample by hand spatula or trowel, then split and reduce sample to required testing size in accordance to AASHTO R47. If sample is not able to be separated or split, place sample in a large, flat pan and warm to $110 \pm 5 \text{ }^\circ\text{C}$ [$230 \pm 9 \text{ }^\circ\text{F}$], only heating the mixture until it is pliable enough to separate. Split or quarter the material until the mass of material required for test is obtained and determine the mass of the sample, W_1 .

NOTE 5—In some cases, polymer modified mixtures need to be warmed at temperatures higher than $110 \text{ }^\circ\text{C}$ [$230 \text{ }^\circ\text{F}$] in order to split or quarter the mix. In all cases, the minimum temperature for the minimum time needed to split the mixture should be used so that any aging to the asphalt binder is minimized.

8.2.2 The size of the test sample shall be governed by the nominal maximum aggregate size of the mixture and shall conform to the mass requirement shown in **Table 1** (Note 6).

NOTE 6—When the mass of the test specimen exceeds the capacity of the equipment used (for a particular method), the test specimen may be divided into suitable increments, tested, and the masses of each increment combined before calculating the asphalt binder content (Section 14).

8.2.3 If the sample was obtained from the field and contains moisture, oven dry the HMA sample to a constant mass at a temperature of $110 \pm 5 \text{ }^\circ\text{C}$ [$230 \pm 9 \text{ }^\circ\text{F}$] or determine the moisture content of the sample according to Test Method **D1461**, so that the measured mass loss can be corrected for moisture. Record mass loss as W_2 . Constant mass is defined as less than 0.05 % loss in mass between consecutive 15-min intervals.

9. Test Method A – Centrifuge Extraction

9.1 Apparatus:

9.1.1 In addition to the apparatus listed in Section 5, the following apparatus is required for Test Method A:

9.1.1.1 *Extraction Apparatus*, of appropriate size to revolve a bowl of approximate dimensions as shown in **Figs. 1 and 2**, which can be controlled by the apparatus at variable speeds up to 3600 r/min. The speed may be controlled manually or with a preset speed control. The apparatus should be provided with a container for catching the effluent thrown from the bowl and a drain for removing the effluent. The apparatus shall be installed in a hood or an effective surface exhaust system to provide ventilation.

9.1.1.2 *Filter Rings*, felt or paper, to fit the rim of the bowl.

9.1.1.3 Low-ash paper filter rings may be used in place of the felt filter ring (9.1.1.2). Such filter rings shall consist of low-ash filter paper stock approximately 1.3 mm thick. The nominal base weight of the paper shall be $150 \pm 14 \text{ kg}$ ($330 \pm$

30 lb) for a 500-sheet ream with sheet size approximately 635 by 965 mm (25 by 38 in.). The ash content of the paper shall not exceed 0.2 % (approximately 0.034 g per ring).

9.2 Procedure:

9.2.1 Prepare the sample and determine the moisture content of the material in accordance with Section 8.

9.2.2 Place a dry sample of 500- to 3000-g test portion into a bowl. Alternatively, place a test portion in a bowl that has been previously dried to a constant mass with the filter ring.

9.2.3 TCE, nPB, or toluene solvents can be used with this extraction method.

9.2.4 Place the bowl containing the test portion onto the extraction apparatus. Cover the test portion in the bowl with solvent and allow sufficient time for the solvent to disintegrate the test portion (not over 1 h). Dry and determine the mass of the filter ring and fit it around the edge of the bowl. Position lid on the bowl and tighten setscrew. Clamp the cover on the bowl tightly and place a beaker under the drain to collect the effluent.

9.2.5 Start the centrifuge revolving slowly and gradually increase the speed to a maximum of 3600 r/min or until solvent ceases to flow from the drain. Allow the machine to stop, add 200 mL of solvent and repeat the procedure. Use sufficient solvent additions (not less than three) so that the extract is not darker than a light straw color. Collect the effluent and the washings in a graduate container.

NOTE 7—Additions of solvent greater than 200 mL may be used as appropriate for the size of the sample.

9.2.6 Drying Procedures:

9.2.6.1 Remove lid from centrifuge bowl, leaving bowl, sample and filter in place. Allow the extracted aggregate to air dry for 15 to 30 min in the ventilated hood. Place bowl, filter ring, and extracted sample into an exhaust oven at $110 \pm 5 \text{ }^\circ\text{C}$ [$230 \pm 9 \text{ }^\circ\text{F}$] for 1 to 2 h to evaporate remaining solvent. Cool bowl, filter ring, and extracted aggregate and if felt filter rings are used, brush off mineral matter adhering to the surface of the ring and add to the extracted aggregate. The mass of the extracted aggregate, W_3 , is equal to the mass of the aggregate in the bowl plus the increase in mass of the filter rings. Report mass measurements to the nearest 0.1 g.

9.2.6.2 Use the following alternative procedure when low-ash filter rings are used: Place the aggregate and filter rings in a clean metal pan. Dry as specified above. Carefully fold the dried filter ring and stand it on the aggregate. Burn the filter ring by igniting with a Bunsen burner or match. Determine the mass of the extracted aggregate in the pan, W_3 . Report mass measurements to the nearest 0.1 g.

9.2.6.3 Since dry aggregate absorbs moisture when exposed to air containing moisture, determine the mass of the extracted aggregate immediately after cooling to a suitable temperature.

9.2.7 Determine the amount of mineral matter in the extract by any of the test methods in Section 13.

9.2.8 Calculate the asphalt binder content as described in Section 14.

10. Test Method B – Reflux Extractor

10.1 Apparatus:

10.1.1 In addition to the apparatus listed in Section 5, the following apparatus is required for Test Method B:

TABLE 1 Size of Sample

Nominal Maximum Aggregate Size Standard, mm	Sieve Size	Minimum Mass of Sample, kg
4.75	(No. 4)	0.5
9.5	$\frac{3}{8}$ in.	1
12.5	$\frac{1}{2}$ in.	1.5
19.0	$\frac{3}{4}$ in.	2
25.0	1 in.	3
37.5	$1\frac{1}{2}$ in.	4

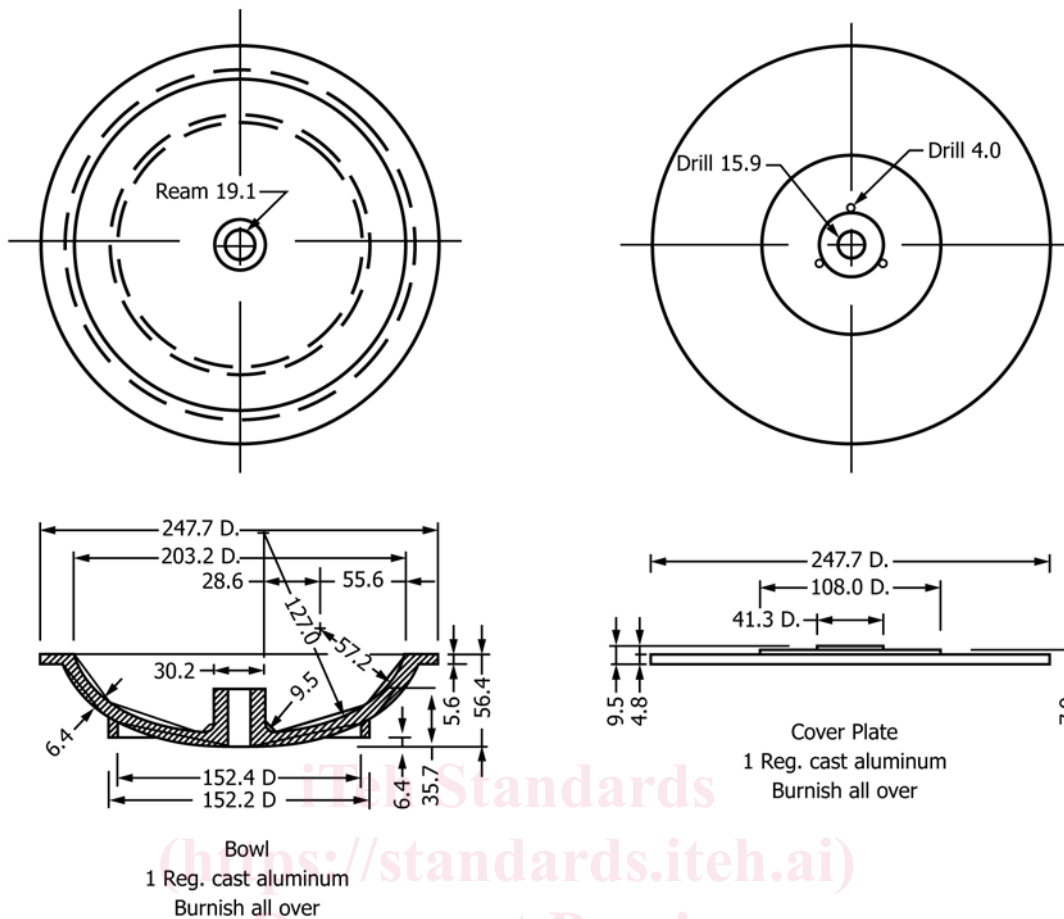

NOTE 1—All dimensions are in millimeters.

FIG. 1 Centrifuge Extraction Unit Bowl (Test Method A)

10.1.1.1 *Extraction Apparatus*, similar to that shown in Fig.

accordance with the directions given below, it shall completely line the metal cones in the frames (see Fig. 4).

10.1.1.2 *Glass Jar*, cylindrical, plain, made of heat-resistant glass. The jar shall be free of cracks, scratches, or other evidence of flaws that might cause breakage during heating.

10.1.1.3 *Cylindrical Metal Frames*, one or two. The lower frame shall have legs of sufficient length to support the frame, including the apex of the metal cone and paper cone liner above the solvent level. When two frames are used, the upper frame shall have legs of sufficient length to support the metal cone and paper cone liner at or above the top rim of the lower frame. The legs of the upper frame shall fit securely in the top rim of the lower frame. A bail handle may be provided on the inside of the top rim of each frame for convenient handling. The metal used in fabricating the frames shall be essentially inactive to the solvents used in the test method.

10.1.1.4 *Condenser*, fabricated with a truncated hemispherical condensing surface and a truncated conical top. Other suitable geometric shapes may also be used provided they accomplish the condensing and flow functions intended. The material used in fabricating the condenser shall be essentially unreactive to water and to the solvent used and shall be provided with suitable water inlet and outlet.

10.1.1.5 *Filter Paper*, medium grade, fast-filtering. The diameter of the paper shall be such that when folded in

10.1.1.6 *Heat Resistant-Coated Wire Mesh*, approximately 3 mm [0.1 in.] thick for use as insulation between the glass jar and hot plate.

10.1.1.7 *Electric Hot Plate*, thermostatically controlled, of sufficient dimensions and heat capacity to permit refluxing of the solvent as described in 10.2.2.5.

10.2 *Procedure:*

10.2.1 Prepare a test portion for moisture determination and extraction in accordance with the procedure described in Section 8.

10.2.2 *Extraction:*

10.2.2.1 Dry and determine the mass of one sheet of filter paper for each frame to be used. Fold each paper on its diameter, fold the ends over, and spread it open to form a proper size to fit inside the metal cones.

10.2.2.2 Determine the mass of each frame with its filter paper liner to the nearest 0.5 g. Record the mass, identifying each frame by number.

10.2.2.3 Place the test portion in the frame or frames. If two frames are used, distribute the test portion approximately equally between the two. The top of the test portion must be



NOTE 1—Similar apparatus of larger size may be used.

FIG. 2 Extraction Unit Bowl (Test Method A)

below the upper edge of the paper liner. Determine the mass of each loaded frame separately to the nearest 0.5 g. Again, record the mass.

10.2.2.4 TCE, nPB, or toluene solvent can be used with this extraction method.

10.2.2.5 Pour the solvent into the glass cylinder and place the bottom frame into it. The solvent level should be below the apex of the one in the (lower) frame. If two frames are used, place the upper frame in the lower frame, fitting its legs into the holes in the upper rim of the lower frame.

NOTE 8—Sufficiently denatured ethyl alcohol may be poured over the test portion(s) to wet the filter paper.

10.2.2.6 Place the thermal insulating pad on the hot plate and then the cylinder on the pad. Cover the condenser. Circulate a gentle, steady stream of cool water through the condenser. Adjust the temperature of the hot plate so that the solvent will boil gently and a steady stream of condensed solvent flows into the cone. If necessary, adjust the temperature of the hot plate to maintain the solvent stream at a rate necessary to keep the test portions in the cone(s) completely covered with condensed solvent. Take care not to allow condensed solvent to overflow the filter cone(s). Continue the refluxing until the solvent flowing from the lower cone is light straw color (when viewed against a white background). At this

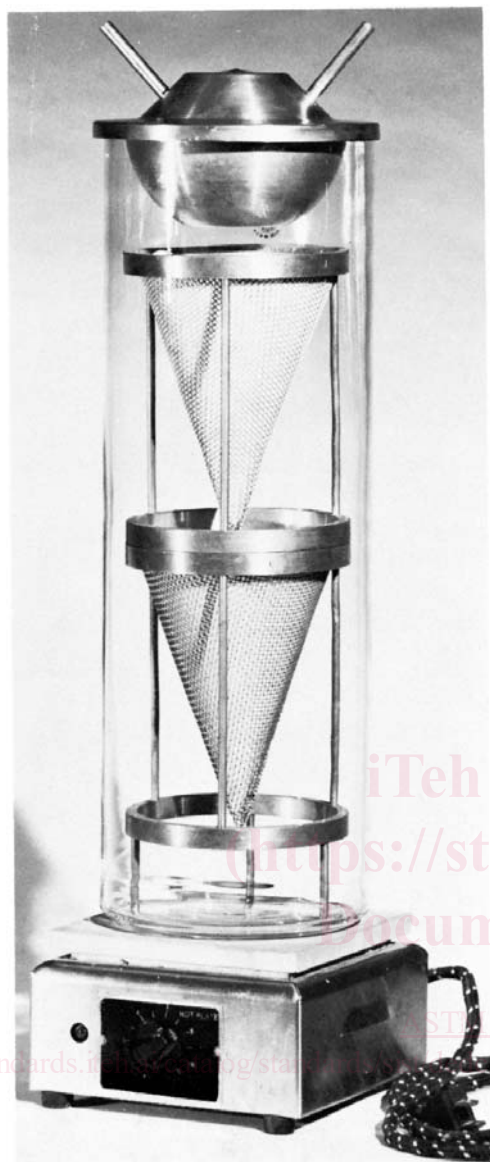

FIG. 3 Reflux Extractor (Test Method B)

point, turn off the hot plate and allow the apparatus to cool with the water running in the condenser. When boiling has ceased and the cylinder is cool enough to handle, turn off the condenser and remove from the cylinder.

10.2.2.7 Remove the frame assembly from the cylinder. Allow to dry in air (hood) and dry to constant mass in an oven at $110 \pm 5^\circ\text{C}$ [$230 \pm 9^\circ\text{F}$].

10.2.3 Determine the amount of mineral matter in the extract by any of the test methods in Section 13.

10.2.4 Calculate the asphalt binder content as described in Section 14.

11. Test Method C – Vacuum Extractor

11.1 Apparatus:

11.1.1 In addition to the apparatus listed in Section 5, the following apparatus is required for Test Method C:

11.1.1.1 *Vacuum Extractor*, complete with vacuum pump, gasket, rubber tubing, filter paper, support plate, and funnel ring, similar to that shown in Fig. 5.

11.1.1.2 *Filter Paper*, medium grade, fast-filtering, 330 mm [13 in.] in diameter.

11.1.1.3 *Stainless Steel Beaker*, having a capacity of approximately 8 L.

11.1.1.4 *Erlenmeyer Flasks*, glass, two, having a capacity of 400 mL each.

11.1.1.5 *Erlenmeyer Flask*, glass, having a capacity of 1000 mL.

11.1.1.6 *Graduate*, glass, having a capacity of 500 mL.

11.1.1.7 *Dial Thermometer*, having a range from 10 to 80 °C [50 to 180 °F].

11.1.1.8 *Watch Glass*, having a 100-mm [4-in.] diameter.

11.1.2 *Miscellaneous Equipment*—Wash bottle, large mixing spatula, stiff-bristled brush, and metal tongs.

11.2 Procedure:

11.2.1 Prepare the sample and determine the moisture content of the material in accordance with Section 8.

11.2.2 TCE, nPB, toluene, or methylene chloride solvent can be used with this extraction method.

NOTE 9—Denatured ethyl alcohol can be used to facilitate the filtering of the asphalt sample.

11.2.3 Initial Sample Preparation:

11.2.3.1 Place the extraction test portion into the tared stainless steel beaker, or alternatively, an ultrasonic cleaning tank, and determine the mass to the nearest 0.1 g.

11.2.3.2 If the test portion is above 54 °C [130 °F], allow sample to cool to a temperature less than 54 °C [130 °F]. When sufficiently cool, pour 200 mL of denatured alcohol over the specimen. Add approximately 700 mL of solvent and stir until the asphalt is visually in solution.

11.2.4 Filter Preparation:

11.2.4.1 Place a dry, tared filter paper on the vacuum extractor, taking care to center the filter, and tighten the wing nuts finger tight.

11.2.5 *Additional Steps for Preparing Extraction of Slow-Filtering Asphalt Mixtures:*

11.2.5.1 Weigh 50 g of oven-dried diatomaceous silica filtering aid into a 100-mL Erlenmeyer flask and add 500 mL of methylene chloride. Swirl until the diatomaceous silica is completely in suspension.

NOTE 10—Fifty (50) g of diatomaceous silica may not be sufficient for all mixes. Some labs have indicated that as the percent passing the 0.075-mm (No. 200) sieve increases, so does the required amount of filtering aid. Good results have been obtained by increasing the amount of diatomaceous silica by 50 g for every 1 % increase in the percent passing the 0.075-mm (No. 200) sieve above 2 %.

11.2.5.2 Immediately pour the diatomaceous silica and solvent over the filter. Start the vacuum pump and let it run until the pad formed by the diatomaceous silica is surface dry and begins to crack slightly.

11.2.5.3 Place the watch glass in the extractor and gently pour the solvent from the test portion over it. Remove the watch glass with tongs and wash with the wash bottle. Add the rest of the sample and proceed with 11.2.6.