



Designation: ~~D2172/D2172M~~ – 11 D2172/D2172M – 17

Standard Test Methods for Quantitative Extraction of Bitumen From Bituminous Paving Asphalt Binder from Asphalt Mixtures¹

This standard is issued under the fixed designation D2172/D2172M; the number immediately following the designation indicates the year of original adoption or, in the case of revision, the year of last revision. A number in parentheses indicates the year of last reappraisal. A superscript epsilon (ϵ) indicates an editorial change since the last revision or reappraisal.

1. Scope

1.1 These test methods cover the quantitative determination of ~~bitumen in hot-mixed paving asphalt binder content in asphalt mixtures and pavement samples. Aggregate extracted from a paving mixture obtained by these methods may be used for sieve analysis using Test Method D5444. This test is not appropriate for testing asphalt mixtures containing coal tar.~~

1.2 Asphalt binder may be recovered using Test Method D1856, Practice D5404/D5404M, or Practice D7906.

1.3 *Units* – The values stated in either SI units or inch-pound units are to be regarded separately as standard. The values stated in each system may not be exact equivalents; therefore, each system shall be used independently of the other. Combining values from the two systems may result in ~~non-conformance~~ nonconformance with the standard.

~~1.2.1 Measurements of volume and mass are only given in SI units because they are the only units typically used in practice when performing this test method.~~

1.4 The text of this standard references notes and footnotes which provide explanatory material. These notes and footnotes (excluding those in tables and figures) shall not be considered as requirements of the standard.

1.5 *This standard does not purport to address all of the safety concerns, if any, associated with its use. It is the responsibility of the user of this standard to establish appropriate safety and health practices and determine the applicability of regulatory limitations prior to use. Specific hazards are given in Section 7.*

NOTE 1—The results obtained by these test methods may be affected by the age of the material tested, with older samples tending to yield slightly lower ~~bitumen~~ asphalt binder content. Best quantitative results are obtained when the test is made on mixtures and pavements shortly after their preparation. It is difficult to remove all the asphalt when some aggregates are used and some chlorides may remain within the mineral matter affecting the measured asphalt content.

1.6 *This international standard was developed in accordance with internationally recognized principles on standardization established in the Decision on Principles for the Development of International Standards, Guides and Recommendations issued by the World Trade Organization Technical Barriers to Trade (TBT) Committee.*

2. Referenced Documents

2.1 *ASTM Standards:*²

C128 Test Method for Relative Density (Specific Gravity) and Absorption of Fine Aggregate

C670 Practice for Preparing Precision and Bias Statements for Test Methods for Construction Materials

D70 Test Method for Density of Semi-Solid Bituminous Materials (Pycnometer Method)

D604 Specification for Diatomaceous Silica Pigment (Withdrawn 2003)³

~~D979~~D979/D979M Practice for Sampling Bituminous Paving Mixtures

D1461 Test Method for Moisture or Volatile Distillates in Bituminous Paving Mixtures

D1856 Test Method for Recovery of Asphalt From Solution by Abson Method

D2111 Test Methods for Specific Gravity and Density of Halogenated Organic Solvents and Their Admixtures

D3666 Specification for Minimum Requirements for Agencies Testing and Inspecting Road and Paving Materials

¹ These test methods are under the jurisdiction of ASTM Committee D04 on Road and Paving Materials and are the direct responsibilities of Subcommittee D04.25 on Analysis of Asphalt Mixtures.

Current edition approved Feb. 1, 2011 April 1, 2017. Published March 2011 April 2017. Originally approved in 1963. Last previous edition approved in 2005 2011 as ~~D2172–05~~ D2172/D2172M – 11. DOI: ~~10.1520/D2172-11~~ 10.1520/D2172_D2172M-17.

² For referenced ASTM standards, visit the ASTM website, www.astm.org, or contact ASTM Customer Service at service@astm.org. For *Annual Book of ASTM Standards* volume information, refer to the standard's Document Summary page on the ASTM website.

³ The last approved version of this historical standard is referenced on www.astm.org.

[D4753 Guide for Evaluating, Selecting, and Specifying Balances and Standard Masses for Use in Soil, Rock, and Construction Materials Testing](#)

[D5404/D5404M Practice for Recovery of Asphalt from Solution Using the Rotary Evaporator](#)

[D5444 Test Method for Mechanical Size Analysis of Extracted Aggregate](#)

[D6368 Specification for Vapor-Degreasing Solvents Based on *normal*-Propyl Bromide and Technical Grade *normal*-Propyl Bromide](#)

[D7906 Practice for Recovery of Asphalt from Solution Using Toluene and the Rotary Evaporator](#)

2.2 ~~Federal Specifications:~~ *AASHTO Standards:*

~~OT-634R47~~ [\(latest\) *normal*-Propyl Bromide, Technical Practice for Reducing Samples of Hot Mix Asphalt \(HMA\) to Testing Size⁴](#)

3. Summary of Test Methods

3.1 The ~~paving asphalt~~ mixture is extracted with ~~trichloroethylene, normal Propyl Bromide, trichloroethylene (TCE), normal propyl bromide (nPB), or methylene chloride~~ using the extraction equipment applicable to the particular method. The ~~bitumen asphalt binder~~ content is calculated by difference from the mass of the extracted aggregate, moisture content, if determined, and mineral matter in the ~~extract. The bitumen effluent (binder-solvent solution).~~ The asphalt binder content is expressed as mass percent of moisture-free mixtures.

4. Significance and Use

4.1 All of these test methods can be used for quantitative determinations of ~~bitumen in hot-mixed paving asphalt binder in asphalt mixtures and pavement samples for specification acceptance, service evaluation, control, and research.~~ Each method prescribes the solvent or solvents and any other reagents that can be used in the test method. ~~Test Method D1856 requires that Method A be used when asphalt is recovered from solution.~~

NOTE 2—Further testing of the asphalt mixture may be performed by using sieve analysis on the extracted aggregate, Test Method D5444, or recovering the extracted asphalt binder from solution by Test Method D1856, Practice D5404/D5404M, or Practice D7906 for asphalt binder property testing. When recovering the asphalt binder for property testing, all mineral matter should be removed from the effluent.

NOTE 3—The quality of the results produced by this standard are dependent on the competence of the personnel performing the procedure and the capability, calibration, and maintenance of the equipment used. Agencies that meet the criteria of ~~Standard Practice Specification D3666~~ are generally considered capable of competent and objective ~~testing/sampling/inspection/etc.~~ testing/sampling/inspection, etc. Users of this standard are cautioned that compliance with ~~Practice Specification D3666~~ alone does not completely assure reliable results. Reliable results depend on many factors; following the suggestions of ~~Practice Specification D3666~~ or some similar acceptable guideline provides a means of evaluating and controlling some of those factors.

5. Apparatus

5.1 *Oven*, capable of maintaining the temperature at $110 \pm 5^\circ\text{C}$ [$230 \pm 10^\circ\text{F}$].

5.2 *Pan*, flat, at least 300 mm [12 in.] long, 200 mm [8 in.] wide, and 25 mm [1 in.] deep, large enough that the asphalt mixture can be spread out in a thin layer over the bottom of the pan.

5.3 *Balance*, or balances having an accuracy of at least 0.01% of the sample mass, readable to 0.1 g, and capable of measuring the mass of sample and container. The balance shall conform to the requirement of Guide D4753, Class GP2.

5.4 *Analytical Balance*, readable to 0.001 g and capable of measuring the mass of the sample and container.

5.5 *Electric Hot Plate*, electric, 700-W continuous or low, medium, and high settings, thermostatically controlled, of sufficient dimensions and heat capacity to permit evaporating or refluxing of the solvent.

5.6 *Small-Mouth Graduate, Graduate Container*, 1000-1000- or 2000-mL capacity. Optional small-mouth graduate, 100-mL capacity.

5.7 *Ignition Dish*, 125-mL 125-mL capacity.

5.8 *Desiccator*, a container with a lid of sufficient size to hold the ignition dish on a perforated drying rack above the top level of the desiccant. The lid should form a good seal around the top of the container so that air movement between the container and the atmosphere is prevented

~~5.8 Analytical Balance:~~

⁴ Available from DLA Document Services, Building 4/D, 700 Robbins Ave., Philadelphia, PA 19111-5094, <http://quicksearch.dla.mil>; American Association of State Highway and Transportation Officials (AASHTO), 444 N. Capitol St., NW, Suite 249, Washington, DC 20001, <http://www.transportation.org>.

6. Reagents

6.1 *Purity of Reagents*—Reagent grade chemicals shall be used in all tests. Unless otherwise indicated, it is intended that all reagents shall conform to the specifications of the Committee on Analytical Reagents of the American Chemical Society,⁵ where such specifications are available. Other grades may be used, provided it is first ascertained that the reagent is of sufficiently high purity to permit its use without lessening the accuracy of the determination.

NOTE 4—Reagents that have exceeded the expiration date should not be used for asphalt mixtures that require asphalt binder property testing. The use of expired solvents may adversely affect the results of asphalt binder property testing.

6.2 Not all solvents (reagents) are applicable to all of the extraction methods detailed in this standard. Each extraction method identifies the specific solvents that can be used.

6.3 ~~Ammonium Carbonate Solution~~Solution—Saturated solution of reagent grade ammonium carbonate [(NH₄)₂CO₃].

6.3 ~~Methylene Chloride~~, technical grade. **Caution**—see Section 7.

6.4 *normal-Propyl Bromide (nPB)*, conforming to Specification **D6368**. **Warning**—~~Caution~~See—see Section 7.

6.5 *Toluene*, reagent grade. **Warning**—See Section 7.

6.6 ~~Trichloroethylene~~, *Trichloroethylene (TCE)*, technical grade, Type 1, Federal Specification O-T-634, latest revision. **Warning**—~~Caution~~See—see Section 7.

6.7 *Methylene Chloride*, reagent grade. **Warning**—See Section 7.

6.8 *Diatomaceous Silica Filtering Aid*, conforming to Type B of Specification **D604**.

6.9 *Ethyl Alcohol*, denatured.

7. Hazards

7.1 **Caution**—**Warning**—The solvents listed in Section 6 should be used only under a hood or with an effective surface exhaust system in a well-ventilated area, since they are toxic to various degrees. Consult the current Threshold Limit Concentration Committee of the American Conference of Governmental Industrial Hygienists⁶ for the current threshold limit values.

8. Sampling

8.1 Obtain samples in accordance with Practice **D979**~~D979~~/**D979M**.

8.2 *Preparation of Test Specimens*:

8.2.1 ~~If the mixture is not sufficiently soft to separate with a spatula or trowel, place it~~Separate sample by hand spatula or trowel, then split and reduce sample to required testing size in accordance to AASHTO R47. If sample is not able to be separated or split, place sample in a large, flat pan and warm to 110 ± 5°C [230 ± 10°F] ~~only until it can be handled or mixed.~~ only heating the mixture until it is pliable enough to separate. Split or quarter the material until the mass of material required for test is ~~obtained.~~ obtained and determine the mass of the sample, W₁.

NOTE 5—In some cases, polymer modified mixtures need to be warmed at temperatures higher than 110 °C [230 °F] in order to split or quarter the mix. In all cases, the minimum temperature for the minimum time needed to split the mixture should be used so that any aging to the asphalt binder is minimized.

8.2.2 The size of the test sample shall be governed by the nominal maximum aggregate size of the mixture and shall conform to the mass requirement shown in **Table 1** (**Note 3**~~6~~).

NOTE 6—When the mass of the test specimen exceeds the capacity of the equipment used (for a particular method), the test specimen may be divided

⁵ *Reagent Chemicals, American Chemical Society Specifications*, American Chemical Society, Washington, DC. For suggestions on the testing of reagents not listed by the American Chemical Society, see *Analar Standards for Laboratory Chemicals*, BDH Ltd., Poole, Dorset, U.K., and the *United States Pharmacopeia and National Formulary*, U.S. Pharmacopeial Convention, Inc. (USPC), Rockville, MD.

⁶ Available from American Conference of Governmental Industrial Hygienists (ACGIH), 1330 Kemper Meadow Dr., Cincinnati, OH 45240, <http://www.acgih.org>.

TABLE 1 Size of Sample

Nominal Maximum Aggregate Size Standard, mm	Sieve Size	Minimum Mass of Sample, kg
4.75	(No. 4)	0.5
9.5	3/8 in.	1
12.5	1/2 in.	1.5
19.0	3/4 in.	2
25.0	1 in.	3
37.5	1 1/2 in.	4

into suitable increments, tested, and the results appropriately combined for calculation of bitumen masses of each increment combined before calculating the asphalt binder content (Section 12.14).

8.2.3 In addition, a test specimen is required for the determination of moisture (Section 9) in the mixtures. Take this test specimen from the remaining sample of the mixture immediately after obtaining the extraction test specimen from the field and contains moisture, oven dry the HMA sample to a constant mass at a temperature of $110 \pm 5^\circ\text{C}$ [$230 \pm 9^\circ\text{F}$] or determine the moisture content of the sample according to Test Method D1461, so that the measured mass loss can be corrected for moisture. Record mass loss as W_2 . Constant mass is defined as less than 0.05 % loss in mass between consecutive 15-min intervals.

NOTE 4—If recovery of bitumen from the solution obtained from the extraction test is not required, the entire test specimen may be dried to constant mass in an oven at a temperature of $110 \pm 5^\circ\text{C}$ [$230 \pm 10^\circ\text{F}$] prior to extraction instead of determining the moisture content (Section 9).

9. Moisture Content Test Method A – Centrifuge Extraction

9.1 Determine the moisture content of the mixture (see 8.2.2) in accordance using the procedure described in Test Method D1461. Apparatus:

9.1.1 In addition to the apparatus listed in Section 5, the following apparatus is required for Test Method A:

9.1.1.1 Extraction Apparatus, of appropriate size to revolve a bowl of approximate dimensions as shown in Figs. 1 and 2, which can be controlled by the apparatus at variable speeds up to 3600 r/min. The speed may be controlled manually or with a preset speed control. The apparatus should be provided with a container for catching the effluent thrown from the bowl and a drain for removing the effluent. The apparatus shall be installed in a hood or an effective surface exhaust system to provide ventilation.

9.1.1.2 Filter Rings, felt or paper, to fit the rim of the bowl.

9.1.1.3 Low-ash paper filter rings may be used in place of the felt filter ring (9.1.1.2). Such filter rings shall consist of low-ash filter paper stock approximately 1.3 mm thick. The nominal base weight of the paper shall be $150 \pm 14\text{ kg}$ ($330 \pm 30\text{ lb}$) for a 500-sheet ream with sheet size approximately 635 by 965 mm (25 by 38 in.). The ash content of the paper shall not exceed 0.2 % (approximately 0.034 g per ring).

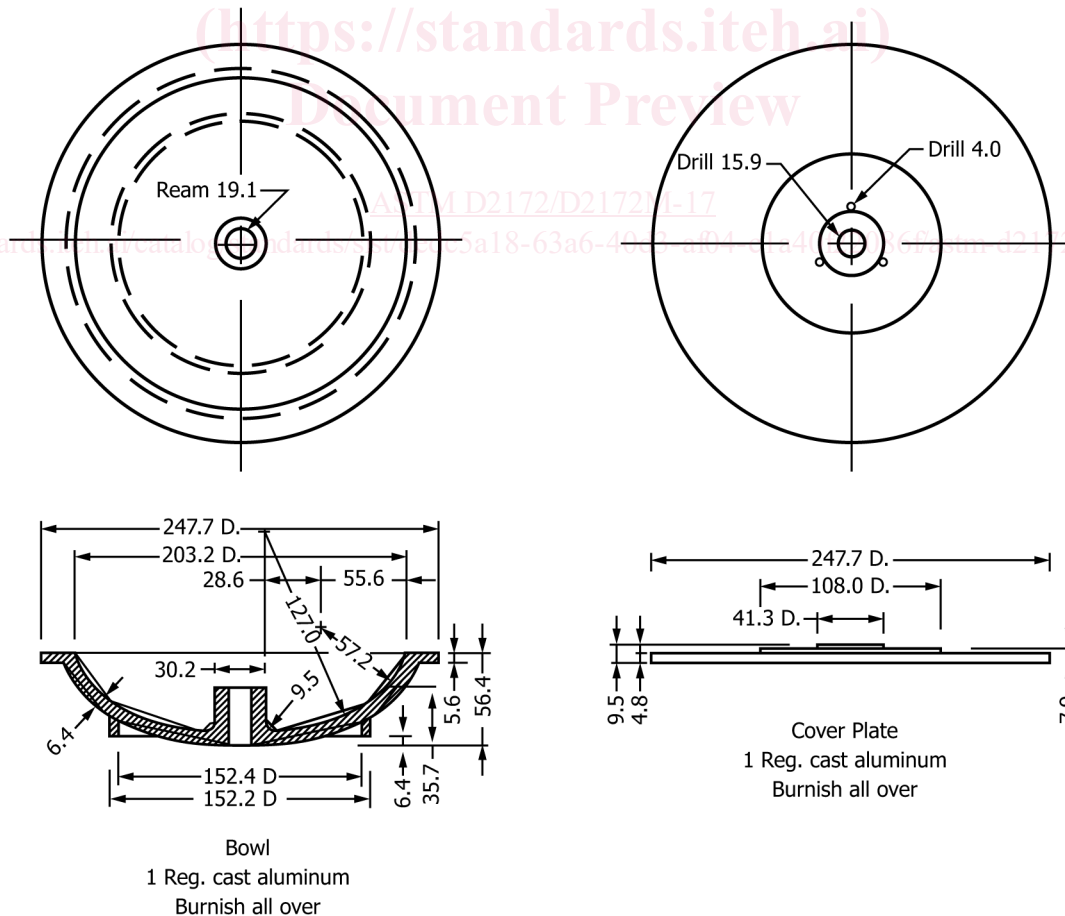

FIG. 1 Centrifuge Extraction Unit Bowl (Test Method A)

NOTE 1—All dimensions are in millimeters.



NOTE 1—Similar apparatus of larger size may be used.

FIG. 2 Extraction Apparatus—Unit Bowl (Test Method B)A)

9.2 Calculate the mass of water, W_2 , (12.1) in the extraction test portion by multiplying mass percent water (9.1) by the mass of the extraction test portion, W_1 , (12.1). Procedure:

9.2.1 Prepare the sample and determine the moisture content of the material in accordance with Section 8.

9.2.2 Place a dry sample of 500- to 3000-g test portion into a bowl. Alternatively, place a test portion in a bowl that has been previously dried to a constant mass with the filter ring.

9.2.3 TCE, nPB, or toluene solvents can be used with this extraction method.

9.2.4 Place the bowl containing the test portion onto the extraction apparatus. Cover the test portion in the bowl with solvent and allow sufficient time for the solvent to disintegrate the test portion (not over 1 h). Dry and determine the mass of the filter ring and fit it around the edge of the bowl. Position lid on the bowl and tighten setscrew. Clamp the cover on the bowl tightly and place a beaker under the drain to collect the effluent.

9.2.5 Start the centrifuge revolving slowly and gradually increase the speed to a maximum of 3600 r/min or until solvent ceases to flow from the drain. Allow the machine to stop, add 200 mL of solvent and repeat the procedure. Use sufficient solvent additions (not less than three) so that the extract is not darker than a light straw color. Collect the effluent and the washings in a graduate container.



NOTE 7—Additions of solvent greater than 200 mL may be used as appropriate for the size of the sample.

9.2.6 *Drying Procedures:*

9.2.6.1 Remove lid from centrifuge bowl, leaving bowl, sample and filter in place. Allow the extracted aggregate to air dry for 15 to 30 min in the ventilated hood. Place bowl, filter ring, and extracted sample into an exhaust oven at $110 \pm 5^\circ\text{C}$ [$230 \pm 9^\circ\text{F}$] for 1 to 2 h to evaporate remaining solvent. Cool bowl, filter ring, and extracted aggregate and if felt filter rings are used, brush off mineral matter adhering to the surface of the ring and add to the extracted aggregate. The mass of the extracted aggregate, W_3 , is equal to the mass of the aggregate in the bowl plus the increase in mass of the filter rings. Report mass measurements to the nearest 0.1 g.

9.2.6.2 Use the following alternative procedure when low-ash filter rings are used: Place the aggregate and filter rings in a clean metal pan. Dry as specified above. Carefully fold the dried filter ring and stand it on the aggregate. Burn the filter ring by igniting with a Bunsen burner or match. Determine the mass of the extracted aggregate in the pan, W_3 . Report mass measurements to the nearest 0.1 g.

9.2.6.3 Since dry aggregate absorbs moisture when exposed to air containing moisture, determine the mass of the extracted aggregate immediately after cooling to a suitable temperature.

9.2.7 Determine the amount of mineral matter in the extract by any of the test methods in Section 13.

9.2.8 Calculate the asphalt binder content as described in Section 14.

TEST METHOD A

10. Apparatus

10.1 In addition to the apparatus listed in Section 5, the following apparatus is required for Test Method A:

10.1.1 *Extraction Apparatus*, consisting of a bowl approximating that shown in Fig. 1 and an apparatus in which the bowl may be revolved at controlled variable speeds up to 3600 r/min. The speed may be controlled manually or with a preset speed control. The apparatus should be provided with a container for catching the solvent thrown from the bowl and a drain for removing the solvent. The apparatus preferably shall be provided with explosion-proof features and installed in a hood or an effective surface exhaust system to provide ventilation.

NOTE 5—Similar apparatus of larger size may be used.

10.1.2 *Filter Rings*, felt or paper, to fit the rim of the bowl.

10.1.3 Low-ash paper filter rings may be used in place of the felt filter ring (10.1.2). Such filter rings shall consist of low ash filter paper stock approximately 1.3 mm [0.05 in.] thick. The ash content of the paper shall not exceed 0.2% (approximately 0.034 g per ring).

11. Procedure

11.1 Determine the moisture content of the material in accordance with Section 9.

11.2 Place a 650 to 2500-g test portion into a bowl. See Annex A1 for alternative procedures to those prescribed herein and in 11.5.

11.3 Cover the test portion in the bowl with trichloroethylene, normal Propyl Bromide, or methylene chloride and allow sufficient time for the solvent to disintegrate the test portion (not over 1 h). Place the bowl containing the test portion and the solvent in the extraction apparatus. Dry and determine the mass of the filter ring and fit it around the edge of the bowl. Clamp the cover on the bowl tightly and place a beaker under the drain to collect the extract.

11.4 Start the centrifuge revolving slowly and gradually increase the speed to a maximum of 3600 r/min or until solvent ceases to flow from the drain. Allow the machine to stop, add 200 mL of trichloroethylene, normal Propyl Bromide, or methylene chloride and repeat the procedure. Use sufficient 200-mL solvent additions (not less than three) so that the extract is not darker than a light straw color. Collect the extract and the washings in a suitable graduate.

11.5 Remove the filter ring from the bowl and dry in air. If felt filter rings are used, brush off mineral matter adhering to the surface of the ring and add to the extracted aggregate. Dry the ring to constant mass in an oven at $110 \pm 5^\circ\text{C}$ [$230 \pm 10^\circ\text{F}$]. Carefully remove all the contents of the bowl into a metal pan and dry on a steam bath and then, dry to constant mass in an oven or on a hot plate at $110 \pm 5^\circ\text{C}$ [$230 \pm 10^\circ\text{F}$]. If trichloroethylene or normal Propyl Bromide is used as the extraction solvent, the preliminary drying on a steam bath may be omitted. The mass of the extracted aggregate, W_3 , is equal to the mass of the aggregate in the pan plus the increase in mass of the filter rings.

11.5.1 Use the following alternative procedure when low-ash filter rings are used: Place the aggregate and filter rings in a clean metal pan. Dry as specified above. Carefully fold the dried filter ring and stand it on the aggregate. Burn the filter ring by igniting with a bunsen burner or match. Determine the mass of the extracted aggregate in the pan, W_3 .

NOTE 6—Since dry aggregate absorbs moisture when exposed to air containing moisture, determine the mass of the extracted aggregate immediately after cooling to a suitable temperature.

11.6 Determine the amount of mineral matter in the extract by any of the following test methods: