



Designation: D8034/D8034M – 17

Standard Test Method for Simulated Service Corrosion Testing of Non-Aqueous Engine Coolants¹

This standard is issued under the fixed designation D8034/D8034M; the number immediately following the designation indicates the year of original adoption or, in the case of revision, the year of last revision. A number in parentheses indicates the year of last reapproval. A superscript epsilon (ϵ) indicates an editorial change since the last revision or reapproval.

1. Scope*

1.1 This test method evaluates the effect of a circulating engine coolant on metal test specimens and automotive cooling system components under controlled, essentially isothermal laboratory conditions.

1.2 This test method specifies test material, cooling system components, type of coolant, and coolant flow conditions that are considered typical of current automotive use.

1.3 The values stated in either SI units or inch-pound units are to be regarded separately as standard. The values stated in each system may not be exact equivalents; therefore, each system shall be used independently of the other. Combining values from the two systems may result in non-conformance with the standard. Some values have only SI units because the inch-pound equivalents are not used in practice.

1.4 *This standard does not purport to address all of the safety concerns, if any, associated with its use. It is the responsibility of the user of this standard to establish appropriate safety and health practices and determine the applicability of regulatory limitations prior to use.* Specific precautionary statements are given in Section 6.

1.5 *This international standard was developed in accordance with internationally recognized principles on standardization established in the Decision on Principles for the Development of International Standards, Guides and Recommendations issued by the World Trade Organization Technical Barriers to Trade (TBT) Committee.*

2. Referenced Documents

2.1 *ASTM Standards:*²

D1121 Test Method for Reserve Alkalinity of Engine Coolants and Antirusts

¹ This test method is under the jurisdiction of ASTM Committee D15 on Engine Coolants and Related Fluids and is the direct responsibility of Subcommittee D15.22 on Non-Aqueous Coolants.

Current edition approved April 1, 2017. Published April 2017. Originally approved in 2016. Last previous edition approved in 2016 as D8034/D8034M-16. DOI: 10.1520/D8034_D8034M-17.

² For referenced ASTM standards, visit the ASTM website, www.astm.org, or contact ASTM Customer Service at service@astm.org. For *Annual Book of ASTM Standards* volume information, refer to the standard's Document Summary page on the ASTM website.

D1123 Test Methods for Water in Engine Coolant Concentrate by the Karl Fischer Reagent Method

D1176 Practice for Sampling and Preparing Aqueous Solutions of Engine Coolants or Antirusts for Testing Purposes

D1193 Specification for Reagent Water

D1287 Test Method for pH of Engine Coolants and Antirusts

D2570 Test Method for Simulated Service Corrosion Testing of Engine Coolants

D7935/D7935M Test Method for Corrosion Test for Non-Aqueous Engine Coolants in Glassware

E203 Test Method for Water Using Volumetric Karl Fischer Titration

2.2 *SAE Standard:*³

SAE J20e Standard for Coolant System Hoses

2.3 *ASTM Adjuncts:*

Coolant reservoir (1 drawing)⁴

Framework for test equipment (3 drawings and B/M)⁵

3. Summary of Test Method

3.1 An engine coolant is circulated for 1064 h at 96.1 °C [205 °F] in a flow loop consisting of a metal reservoir, an automotive coolant pump, an automotive radiator, and connecting rubber hoses. Test specimens representative of engine cooling system metals are mounted inside the reservoir, which simulates an engine cylinder block. At the end of the test period, the corrosion-inhibiting properties of the coolant are determined by measuring the mass losses of the test specimens, and by visual examination of the interior surfaces of the components.

4. Significance and Use

4.1 This test method, by a closer approach to engine cooling system conditions, provides better evaluation and selective screening of engine coolants than is possible from glassware

³ Available from SAE International (SAE), 400 Commonwealth Dr., Warrendale, PA 15096, http://www.sae.org.

⁴ Detail drawings are available from ASTM International Headquarters. Order Adjunct No. **ADJD257001**. Original adjunct produced in 1982. Reservoirs of cast iron or cast aluminum, made in accordance with these drawings may be obtained from Commercial Machine Service, 1099 Touhy Ave., Elk Grove Village, IL 60007.

⁵ Detail and assembly drawings of a suitable framework and arrangement of components thereon are available from ASTM International Headquarters. Order Adjunct No. **ADJD257002**. Original adjunct produced in 1982.

*A Summary of Changes section appears at the end of this standard

testing (Test Method D7935/D7935M). The improvement is achieved by controlled circulation of the coolant, by the use of automotive cooling system components, and by a greater ratio of metal surface area to coolant volume.

4.2 Although this test method provides improved discrimination, it cannot conclusively predict satisfactory corrosion inhibition and service life. If greater assurance of satisfactory performance is desired, it should be obtained from full-scale engine tests and from field testing in actual service.

4.3 Significance and interpretation of the test and its limitations are discussed further in Appendix X1.

4.4 The substitution of components in the apparatus of Section 5 is permissible if agreed upon by the contracting parties.

5. Apparatus

5.1 *Reservoir*—An assembly drawing of this component⁴ is shown in Fig. 1. The material of construction, representing that of the engine cylinder block, shall be SAE G3500 Gray Iron for Automotive Castings.⁶ No air line is to be attached.

5.2 *Automotive Components*—These shall be those normally used with a 4-, 6-, or 8-cylinder automobile engine used in current automobiles in the United States, in the 1.6 to 5.0-L [98 to 305-in.³] range of piston displacement. General characteristics shall be as follows:

5.2.1 *Radiator*—Aluminum radiator, GM part No. 3093506, or equivalent, may be used subject to mutual agreement of the

⁶ Aluminum or iron may be used if mutually agreed upon between the parties involved.

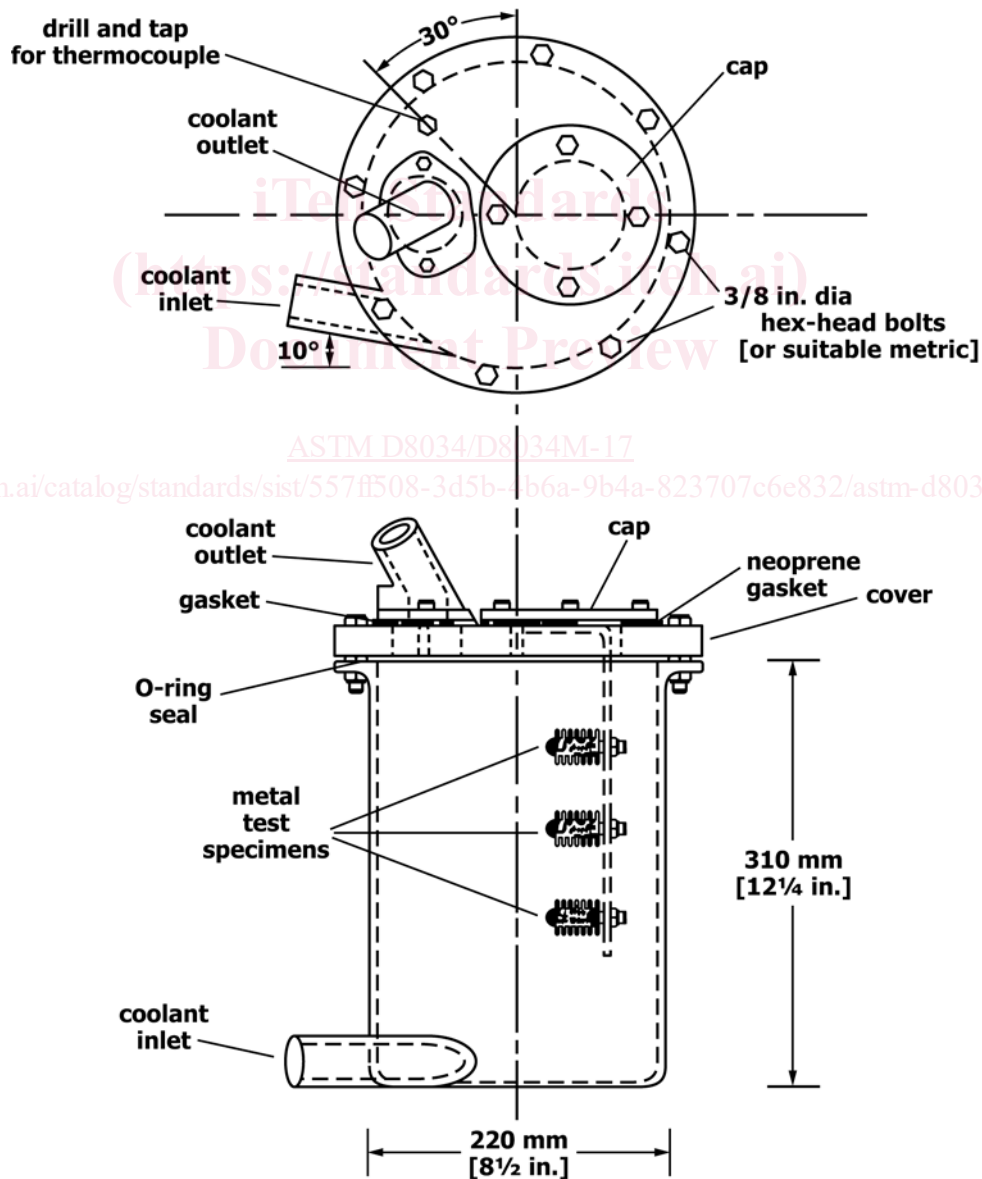

FIG. 1 Reservoir

parties involved. The radiator has a “neck” with a hose nipple and the top of the neck accepts a pressure cap.

5.2.2 *Radiator Pressure Cap*—80 to 100 kPa [12 to 15 psig], GM part No. 6410427. The pressure valve in the cap is removed so as to allow free movement of coolant into and out of the hose nipple. The only purpose of the cap is to be able to open or close the opening at the top of the radiator neck.

5.2.3 *Pressurized Expansion Tank*—A plastic tank approximately 2 L, capable of withstanding a gauge pressure of 136 kPa [20 psig] at 96.1 °C [205 °F]. The tank has an opening at the top to accept a pressure cap and a nipple at the bottom to accept a hose. Any other openings are sealed.

5.2.4 *Expansion Tank Pressure Cap*—80 to 100 kPa [12 to 15 psig] to fit the opening at the top of the expansion tank.

5.2.5 *Coolant Pump*—GM part No. 14033483 (aluminum matching front end cover). GM part No. 14033526 (aluminum provides back cover), coolant discharge parts and mounting for pump, or equivalent, may be used subject to mutual agreement of the parties involved.

5.2.6 *Coolant Outlet*—GM part No. 14033198 (aluminum), or equivalent, may be used subject to mutual agreement of the parties involved.

5.2.7 *Hoses*—Reinforced elastomer, meeting the requirements of SAE J20e Type 20R1 Standard Wall Class D-2

requirements; heat-resistant cover; temperature rating: -40 to 125 °C [-40 to 257 °F].

5.2.8 *Hose Clamps*—Preferably worm-screw type (constant tension may be used).

5.3 *Pipe Fittings*—The preferred material for the fittings required in the hose connections between pump discharge ports and reservoir inlet is malleable cast iron. A satisfactory alternative is steel.

5.4 *Electric Motor*—1.1 kW [1½ hp] or larger, drip-proof or explosion-proof in accordance with local safety regulations.

5.5 *Pulleys and Drive Belt*—Sized to drive the pump at a speed that will produce a flow rate of 1.3 to 1.6 L/s [20 to 25 gal/min] for the General Motors 2.8-L [173-in.³] V-6 engine. The flow rate at operating temperature is determined by a flow measurement device⁷ located between pump discharge and reservoir inlet, as indicated in Fig. 2. The pressure drop between pump discharge and reservoir inlet, measured by the pressure gages shown in Fig. 2, must be maintained when the flow measurement device is removed from the system. This

⁷ Flow rate indicator, 0.3 to 3.0 L/s [4 to 50 gal/min], of bronze construction is satisfactory.

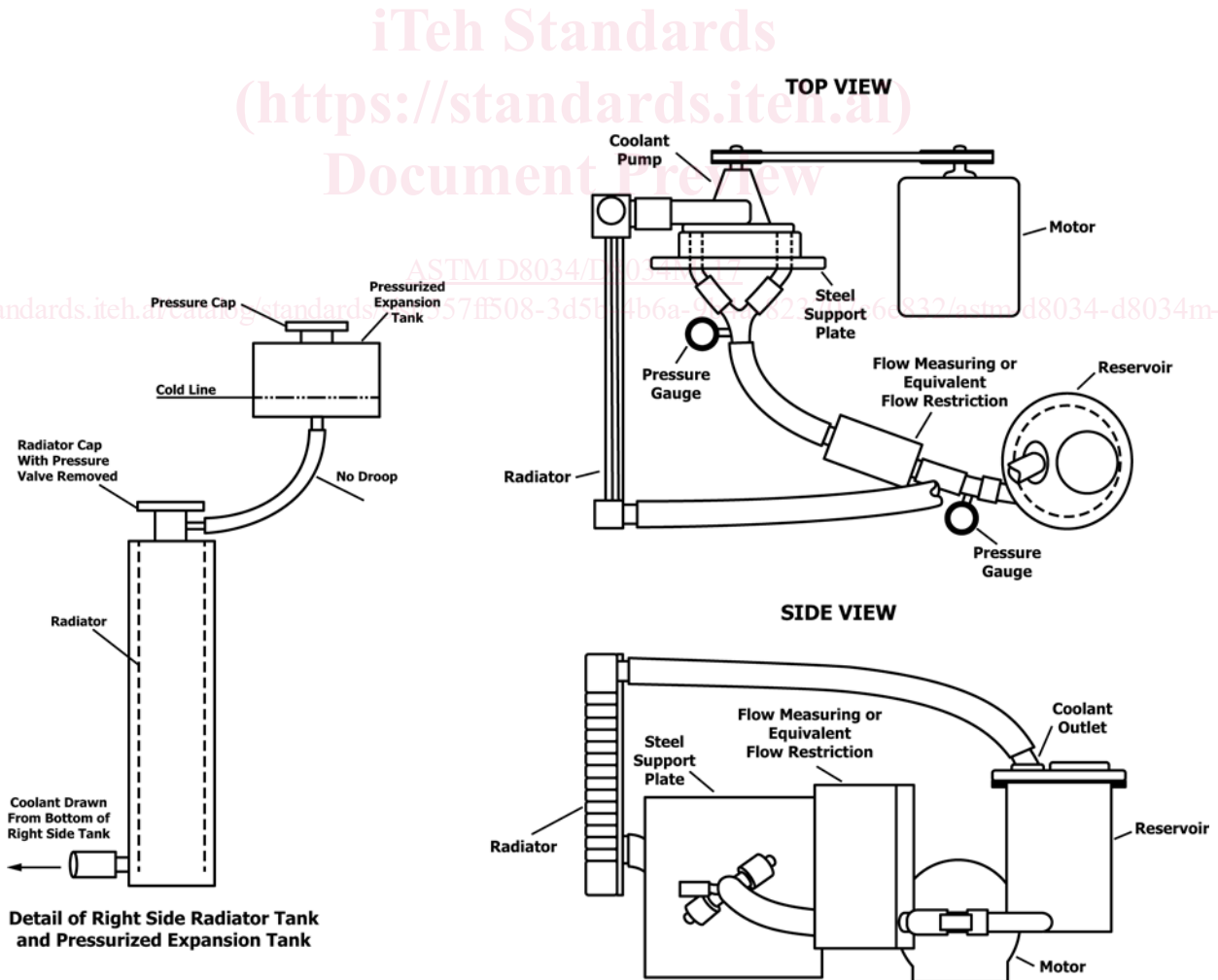

FIG. 2 Assembly of Test Apparatus

can be done by substituting for the flow measurement device a variable-flow restriction, such as a valve, which can be adjusted to produce the same pressure drop as that measured across the flow measurement device at the specified flow rate.

5.6 Electric Heater—About 2000 W, either a hot plate installed under the reservoir, or a circumferential, metal-clad heater band around the reservoir.

5.7 Thermoregulator—A suitable temperature regulator shall be used to maintain the coolant temperature between the limits specified by 9.3. The sensing unit of the regulator shall be installed in an opening on the reservoir cover.

5.8 Temperature Measuring Device—A thermocouple and read-out instrument capable of indicating coolant temperature to the nearest 0.5 °C shall be installed in an opening on the reservoir cover.

5.9 Framework—A suitable framework shall be used to mount all the components as a unit.⁵

NOTE 1—The apparatus required for this test method is similar to that required for Test Method D2570. Test Method D2570 Section 5 Apparatus includes possible component sources.

6. Safety Precautions

6.1 System Pressure—Protection against bursting shall be provided by a working pressure-relief cap at the top of the expansion tank. A safety enclosure is also recommended. When power is applied to the heating element(s), the pump shall be turned on and circulating the test fluid.

6.2 Pump Drive—A safety guard for the coolant pump drive belt and pulleys shall be provided.

6.3 Electrical—Electrical circuits required for operation of motor, heater, and thermo-regulator shall be installed with suitable precautions against electrical shock to operating personnel in the event of accidental spills of electrically conductive liquids.

6.4 Thermal—Protection of operating personnel against burns from exposed metal surfaces, especially those of the heater, shall be provided.

6.5 Plumbing—Protection of operating personnel against burns or scalds from hot fluid escaping from burst hoses or failed plumbing connections shall be provided.

7. Metal Test Specimens

NOTE 2—Current production vehicles may have differing alloy. Therefore, specimens other than those designated in this test method may be used by mutual agreement of the parties involved.

7.1 The description, specification, preparation, cleaning, and weighing of the metal test specimens to be used in this test method are given in detail in Test Method D7935/D7935M. However, the solid solder specimen allowed as an alternative in Test Method D7935/D7935M shall not be used in this test method, as it has been known to bend and contact an adjoining specimen. Specimens containing high lead solder, or low lead solder, or both, may be used subject to mutual agreement of the parties involved.

NOTE 3—The procedure for the cleaning of aluminum alloy coupons

was changed in 1995 to eliminate the use of chromic acid, a recognized health hazard.

7.2 Arrangement—The metal test specimens shall be drilled through the center with a 6.8-mm [¹⁷/₆₄-in.] drill to accommodate a 65-mm [2½-in.] 10–24 brass machine screw covered with a thin-walled insulating sleeve. Polytetrafluoroethylene tubing with a 6.4-mm [¹/₄-in.] outside diameter and a wall thickness of 0.4 mm [¹/₆₄ in.] is satisfactory. The standard test “bundle” shall be assembled on the insulated screw with the specimens in the following order, starting from the screw head: copper, solder, brass, steel, cast iron, and cast aluminum. The specimens shall be separated by 5-mm [³/₁₆-in.] thick solid metal and insulating spacers having a 6.8-mm [¹⁷/₆₄-in.] inside diameter and an 11-mm [7.16-in.] outside diameter. Brass spacers shall be used between the copper, solder, and brass specimens, and steel spacers between the steel, cast iron, and cast aluminum specimens. Insulating spacers made from polytetrafluoroethylene shall be used between the screw head and the copper specimen, between the brass and steel specimens, and between the cast aluminum specimen and a brass nut. The nut shall be tightened firmly to ensure good electrical contact between the test specimens in each section of the bundle. As shown in Fig. 3, each bundle shall be positioned on a bracket mounted on the cap of the reservoir and fastened in place with another brass nut; the 50.8-mm [2-in.] dimensions of the test specimens shall be horizontal when inserted into the reservoir.

8. Test Solution

8.1 The coolant to be tested shall be a 94 % by volume non-aqueous coolant prepared with corrosive water (Note 4). The corrosive water shall contain 100 ppm each of sulfate, chloride, and bicarbonate ions introduced as the sodium salts. Preparation of the sample shall be done in accordance with Section 6 of Practice D1176, with corrosive water used for dilution. Thus, any insoluble materials will be included in the representative sample.

NOTE 4—1 L of the specified corrosive water can be prepared by dissolving the following amounts of anhydrous sodium salts in a quantity of distilled or deionized water:

Sodium sulfate	148 mg
Sodium chloride	165 mg
Sodium bicarbonate	138 mg

The resulting solution should be made up to a volume of 1 L with distilled or deionized water at 20 °C.

9. Test Conditions

9.1 **Assembly**—The essential arrangement of the reservoir, radiator, coolant pump, and connecting hoses is shown in Fig. 2. The gasketed coolant outlet is bolted to the reservoir cover.

9.2 **Coolant Flow**—The coolant flow shall be maintained at 1.3 to 1.6 L/s [23 ± 1 gal/min].

9.3 **Temperature**—The test coolant shall be maintained at a temperature of 96 ± 3 °C [205 ± 5 °F] throughout the test except during shutdown periods.

9.4 **Duration**—The test shall be run for 152 h/week for 7 weeks. Operation shall be continuous, except for two 8-h shutdowns each week, until 1064 h of operation have been completed.