



Designation: D1826 – 94 (Reapproved 2017)

Standard Test Method for Calorific (Heating) Value of Gases in Natural Gas Range by Continuous Recording Calorimeter¹

This standard is issued under the fixed designation D1826; the number immediately following the designation indicates the year of original adoption or, in the case of revision, the year of last revision. A number in parentheses indicates the year of last reapproval. A superscript epsilon (ϵ) indicates an editorial change since the last revision or reapproval.

1. Scope

1.1 This test method covers the determination with the continuous recording calorimeter (**Note 1**) of the total calorific (heating) value of fuel gas produced or sold in the natural gas range from 900 to 1200 Btu/standard ft³.

NOTE 1—An extensive investigation of the accuracy of the Cutler-Hammer recording gas calorimeter, when used with gases of high heating value, was made by the National Bureau of Standards in 1957 under a research project sponsored by the American Gas Association.

1.2 The subjects covered in this test method appear in the following sections:

	Sections
Air-Gas Ratio Test	11
Apparatus	5
Basis of Measurement	14
Cold Balance Test	10
Compensation of Complicating Factors	13
Condition of Gas Sample	7
Definitions	2
Installation of Apparatus	6
Maintenance	Appendix X1
Operating Precautions	Appendix X2
Operation and Checking of Apparatus	9
Precision	15
Scope	1
Significance and Use	4
Standardization of Calorimeter	12
Standardization, Preliminary, of Calorimeter by Hydrogen	8
Summary of Test Method	3

1.3 *This standard does not purport to address all of the safety concerns, if any, associated with its use. It is the responsibility of the user of this standard to establish appropriate safety and health practices and determine the applicability of regulatory limitations prior to use.*

1.4 *This international standard was developed in accordance with internationally recognized principles on standardization established in the Decision on Principles for the Development of International Standards, Guides and Recommendations issued by the World Trade Organization Technical Barriers to Trade (TBT) Committee.*

¹ This test method is under the jurisdiction of ASTM Committee D03 on Gaseous Fuels and is the direct responsibility of Subcommittee D03.03 on Determination of Heating Value and Relative Density of Gaseous Fuels.

Current edition approved April 1, 2017. Published April 2017. Originally approved in 1961. Last previous edition approved in 2010 as D1826 – 94 (2010). DOI: 10.1520/D1826-94R17.

2. Terminology

2.1 Definitions of Terms Specific to This Standard:

2.1.1 The most important terms used in connection with the determination of the calorific value of gaseous fuels in recording calorimetry are as follows:

2.1.2 *British Thermal Unit, or Btu*—is the defined International Tables British thermal unit (symbol Btu).

NOTE 2—The defining relationships are:

(a) 1 Btu·lb⁻¹ = 2.326 J·g⁻¹ (exact)

(b) 1 lb = 453.592 37 g (exact).

By these relationships, 1 Btu = 1 055.055 852 62 J (exact). For most purposes, the value rounded to 1 Btu = 1 055.056 J is adequate.

2.1.3 *combustion air*—air used for combustion, a total of the portion mixed with the gas as primary air and the air supplied around the burner tube as secondary air (theoretical air plus excess air).

2.1.4 *flue gases*—the products, of combustion remaining in the gaseous state, together with any excess air.

2.1.5 *heat-absorbing air*—the heat exchange medium used to absorb the heat of combustion derived from the burning of gaseous fuel.

2.1.6 *saturated basis*—the expressed total calorific value of a gas when it is saturated with water vapor at standard temperature and pressure; 1 ft³ of this gas is equivalent in dry gas content to 0.9826 ft³ of dry gas at the standard temperature of 60°F and standard pressure of 14.73 psia.

NOTE 3—The definitions given in 2.1.6 and 2.1.10 are for total calorific (heating) values per standard cubic foot of gas. The definitions corresponding to any other unit quantity of gas are obtained by substituting the name of the desired unit in place of the term “standard cubic foot” in the definitions. Methods of calculating calorific (heating) values per cubic foot of gas under any desired conditions of pressure, temperature, and water vapor content are specified in Section 14.

2.1.7 *standard cubic foot of gas*—the quantity of any gas that at standard temperature and under standard pressure will fill a space of 1 ft³ when in equilibrium with liquid water.

2.1.8 *standard pressure*—is 14.73 psia.

NOTE 4—This is the pressure base adopted by the American National Standards Institute in 1969 (Z132.1). According to Dalton’s law, this is equivalent to stating that the partial pressure of the gas is:

$$14.73 - 0.256\ 36 = 14.473\ 64\ \text{psia}$$

where 0.256 36 is the vapor pressure of water in psia at 60°F.

2.1.9 *standard temperature*—60°F, based on the international practical temperature scale of 1968.

2.1.10 *total calorific value (gross heating value, higher heating value)*—of a gas is the number of British thermal units evolved by the complete combustion at constant pressure of one standard cubic foot of gas with air, the temperature of the gas, air, and products of combustion being 60°F, and all the water formed by the combustion reaction being condensed to the liquid state.

3. Summary of Test Method

3.1 The heating value is determined by imparting all of the heat obtained from the combustion of the test gas to a stream of air and measuring the rise in temperature of the air. The streams of test gas and heat absorbing air are maintained in fixed volumetric proportion to each other by metering devices similar to the ordinary wet test meters geared together and driven from a common electric motor. The meters are mounted in a tank of water, the level of which is maintained and the temperature of which determines the temperature of the entering gas and air.

3.2 The flue gas resulting from combustion of the gas (combustion products plus excess combustion air) is kept separate from the heat-absorbing air and is cooled to a few degrees above the initial temperature of gas and air. The water formed in the combustion is practically all condensed to the liquid state. Consequently, the temperature rise produced in the heat-absorbing air is directly proportional to the heating value of the gas. Since all the heat from the combustion of the test gas sample, including the latent heat of vaporization of the water vapor formed in the combustion, is imparted to the heat-absorbing air, the calorimeter makes a direct determination of total heating value. The temperature rise is measured by nickel resistance thermometers and is translated into Btu per standard cubic foot.

4. Significance and Use

4.1 This test method provides an accurate and reliable method to measure the total calorific value of a fuel gas, on a continuous basis, which is used for regulatory compliance, custody transfer, and process control.

5. Apparatus

5.1 The recording calorimeter (Note 5) consists of two major units; the tank unit or calorimeter proper, Fig. 1, Fig. 2, and Fig. 3, in which the heating value of the test gas sample is measured; and the recording unit which translates the heat measurements into an indication of calorific (heating) value and records it graphically on a strip chart recorder or digitally if the new SMART-CAL is used (Note 6).

NOTE 5—The previous specified pressure base was the absolute pressure of a column of pure mercury 30 in. in height at 32°F and under standard gravity (32.174 ft/s²). This is equivalent to 14.7346 psia.

NOTE 6—Refer to specific manufacturer's manual for pictures of the recorder or the SMART-CAL, a digital indicating or printing device, currently used on new or retrofitted calorimeters.

6. Installation of Apparatus

6.1 To secure the precise results that are possible with the recording calorimeter, it is important that the instrument be installed so that the surrounding conditions will not introduce errors. In general, more precise results will be secured when a narrow range is maintained on the various conditions of the calorimeter environment.

6.2 *Calorimeter Room*—A typical installation of a single recording calorimeter is shown in Fig. 4. The detailed requirements for the calorimeter room are given in Table 1.

NOTE 7—A detailed discussion of these requirements is included in the latest edition of the manufacturer's instruction book covering the recording calorimeter. The information can be applied to all models of the instrument.

NOTE 8—The dimensions shown in Fig. 4 are for the latest model calorimeter.

6.3 *Gas Connection*—Locate the sample line that brings the gas to be tested to the calorimeter tank unit so that the heating value is actually representative of the conditions existing in the main gas line. Keep the sample line time lag as small as possible by (1) locating the calorimeter tank unit close to the sample point, (2) running the sample line of small size pipe (Note 9), and (3) operating the sample line at low pressure. Provide an additional purge burner or a bleed to a low pressure point.

NOTE 9—Time lag may be calculated on the basis that the calorimeter uses about 1.2 ft³/h.

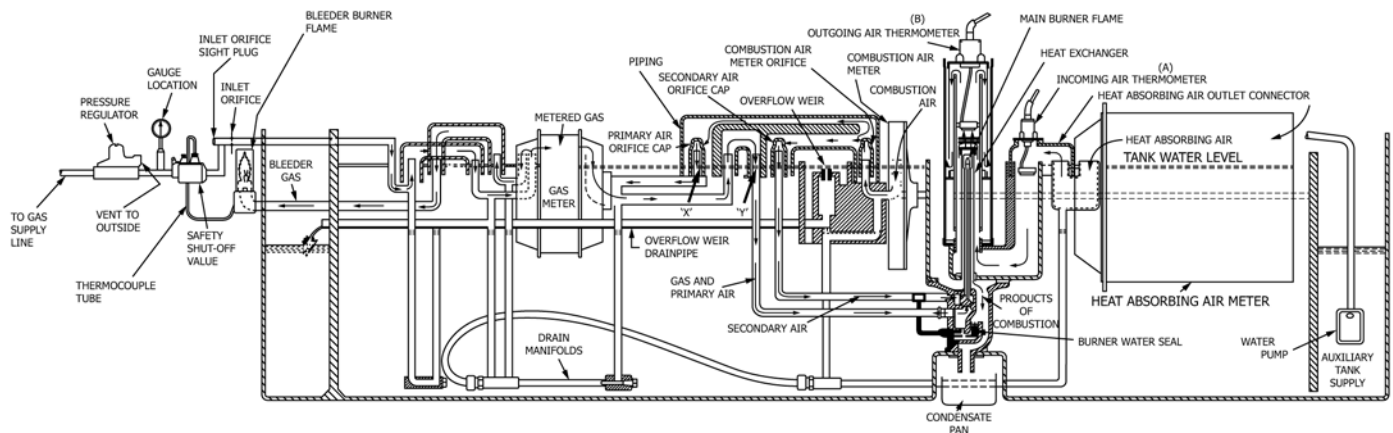

FIG. 1 Calorimeter—Schematic Flow Diagram

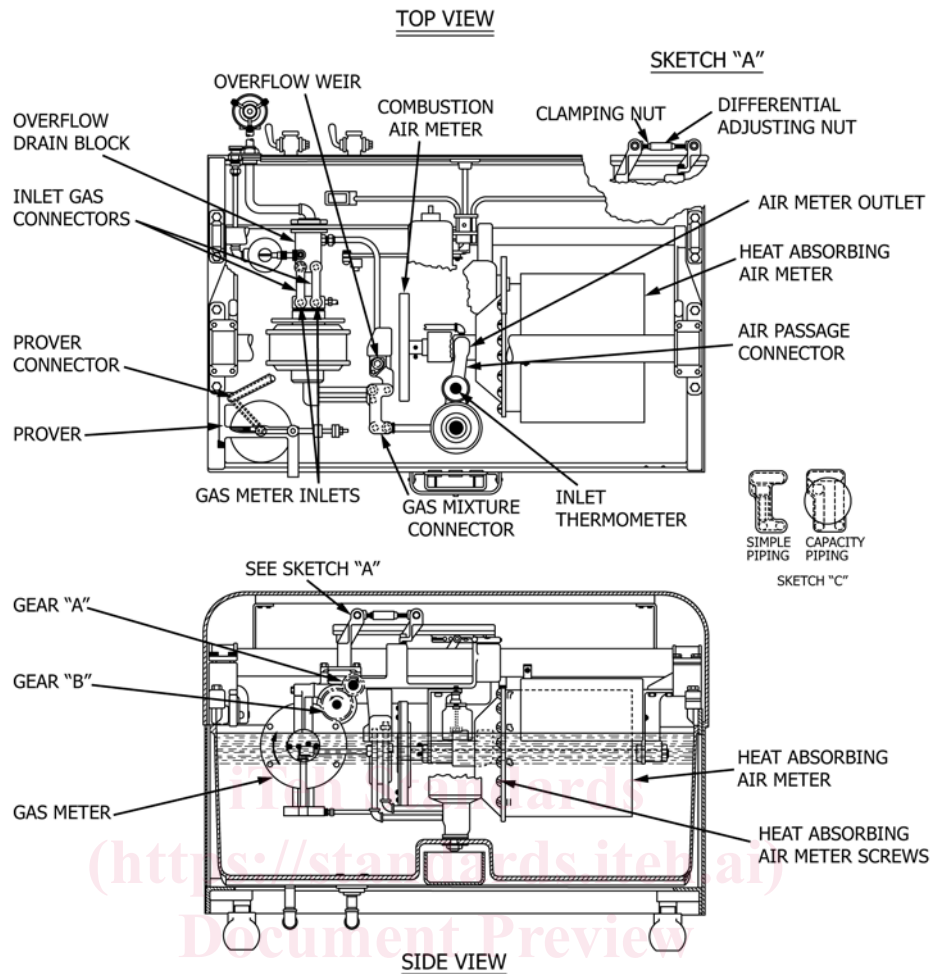

FIG. 2 Calorimeter—Layout Diagram

ASTM D1826-94(2017)

6.4 *Electrical Wiring*—The four leads for the resistance thermometers between either the recorder or the Smart-Cal junction box and the tank unit shall be of No. 12 gage, insulated, solid copper wire without joints. Run in a separate rigid metal conduit which is grounded and contains no other leads (Note 10). Power circuit wiring should be No. 14 gage, insulated, solid or stranded, copper wire. Provide the supply line with a suitably fused disconnect switch. For the model using an electronic recorder, it is essential that a suitable ground connection be made at both the recorder and the tank unit. Details are given in the manufacturer's instructions.

NOTE 10—Where outdoor or underground wiring must be used, special care should be exercised to protect the terminals of the cables from moisture to prevent grounds in the measuring circuit.

6.5 *Initial Installation*—When the calorimeter is first installed, fill the tank unit with water (Note 11) and adjust it to a temperature that is 2 to 5°F below the normal room temperature. Allow the unit to operate at least 24 h before performing the detailed calibration tests.

NOTE 11—The water may be ordinary tap water supplied by most municipalities. If, however, it is found that excessive quantities of deposits and sludge are formed in short duration which interfere with satisfactory

performance, it will be necessary to use distilled or demineralized water with a pH of 7.

NOTE 12—For actual test instructions and other information, see the appropriate instruction book provided by the manufacturer.

6.6 *Recorder Installation*—Install the recorder so that the instrument is reasonably free from mechanical vibration. This is particularly important for those models in which a suspension-type galvanometer is used.

7. Condition of Gas Sample

7.1 *Physical Contamination*—The gas sample should be free of dust, water, and other entrained solids. If experience indicates that the foreign materials can enter the sample line, install a suitable sample line filter. To avoid any problems in the line from water accumulation, pitch the line to a low point and provide a drip leg.

7.2 *Chemical Contamination*—The sample line should be practically free from hydrogen sulfide. A small, low-capacity purifier can be constructed using iron oxide on wood shavings as the purifying material. The time lag in the purifier adds to

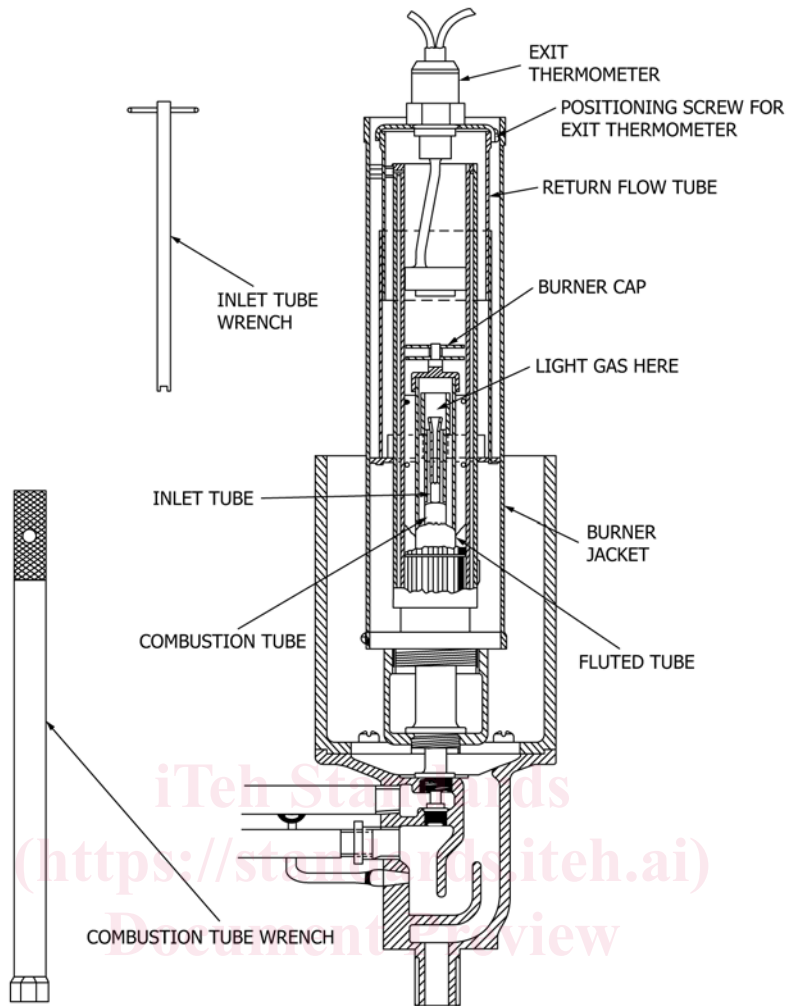
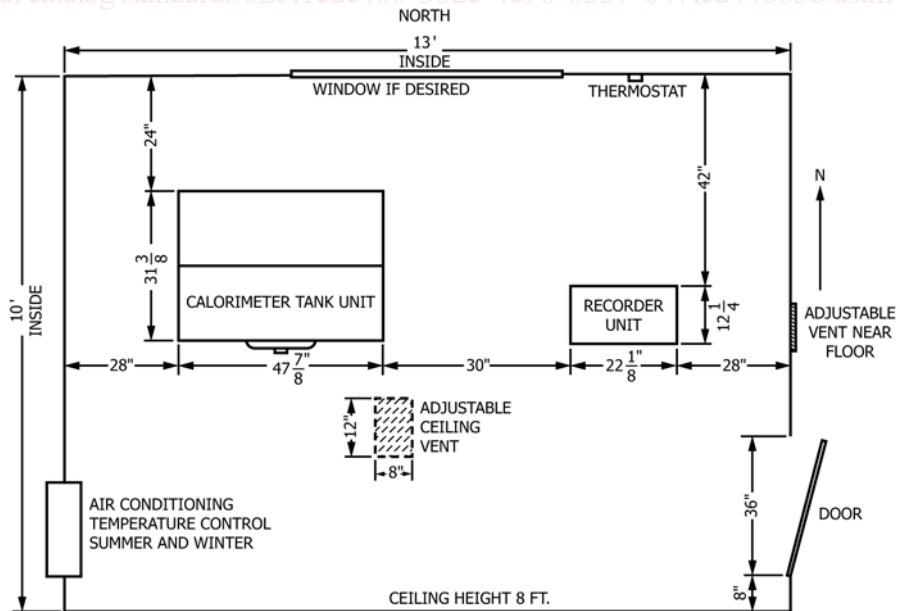

FIG. 3 Calorimeter Combustion Chamber

<https://standards.iteh.ai/catalog/standards/sist/fl ede406-382c-4e96-8337-047fcd44b65b/astm-d1826-942017>



NOTE 1—For each additional calorimeter at least 50 % additional space is required; for example, for two calorimeters the room should be 12 by 18 ft inside; for three calorimeters 15 by 18 ft.

FIG. 4 Calorimeter Room

TABLE 1 Calorimeter Room Requirements

Detail	Requirements
Space	1000 ft. ³ min.
Ceiling height	8 ft. min.
Side wall widths	10 and 13 ft. min.
Windows	One, on side normally away from sun (in northern hemisphere, the northern side).
Doors	One, with 3-ft opening, not in window wall. A door check is desirable.
Ventilation	Natural ventilation using ceiling vent and a vent at floor level. Both should be located away from the tank unit.
Tank location	The tank unit should be in a draft-free location with respect to heating and cooling units and natural ventilation.
Heating and cooling	Controlled in the range 60 to 75°F with a variation of not more than 2.5°F from the set point.
Foundation floor	The calorimeter should remain level at all times. Design for 3000-lb static and dynamic load. The tank feet should be on load bearing parts of the floor.
Lighting	No direct sunlight permitted on calorimeter tank unit.
Condition of air	Essentially free from dust and absolutely free from any combustible gas for both measurement accuracy and safety. Trace hydrocarbons can be removed from combustion air using a Hoskins furnace and a combustion air meter hood.
Vibration	No vibrations or shocks shall be transmitted to the tank unit.
Water	Pure pH-7 clean water shall be available for filling the tank and replenishing the reserve tank.
Power supply	115 V, 1 phase, 60 Hz, 1000 W for small motors. Lighting, heating, and cooling in addition.
Gas supply	Sample pipe shall be ¼-in. tubing. Pressure shall be cut at the pipeline to 1½ to 2 psig for minimum time lag. Pressure at the calorimeter shall be 6 to 30 in. w.c.
Water supply and drain	Desirable but not essential.
Radiation	Tank unit shall be shielded from any hot radiation surfaces.
Safety	It should be remembered that the calorimeter has open flames. Natural ventilation is sufficient in nonhazardous locations and where only the aforementioned ¼-in. tubing service for natural gas at 1 psig is used. Hydrocarbon vapor detectors and purging means should be considered for installations where location can be hazardous, where higher pressure gas is present, or where gases heavier than air are involved. In all installations, lighting installations should be suitable for Division I, and incoming power from underground services should have sealoffs.

the sample line time lag so that the purifier should be of small capacity. A design that will purify about 3 ft³ of gas/h will be satisfactory.

8. Preliminary Standardization of Calorimeter by Hydrogen

8.1 The use of preliminary standardization by hydrogen test gas before the use of standard methane at the time of the initial installation or after any complete major overhaul of the tank unit and recorder is required, because of the following factors:

8.1.1 Because of the low density of hydrogen, the presence of any leaks in the system from the gas meter to the burner will result in a definite low reading. This situation should certainly be considered on the initial installation and whenever the gas meter assembly has been dismantled for inspection or cleaning.

8.1.2 The hydrogen test gives another cross-check of the slide wire and thermometer calibration at a different point on the scale of the instrument. A satisfactory hydrogen test gives additional assurance that no error exists in this part of the instrument.

8.1.3 There is practically no possibility of incomplete combustion on the hydrogen test. Therefore, a satisfactory hydrogen result gives assurance that, with the proper heat input, the correct calorific value reading will be secured. If a satisfactory hydrogen test has been secured and a low reading has been obtained on the standard gas, the possibility of incomplete combustion could be suspected. Without the hydrogen test, there might be some tendency to make adjustments to compensate in another way for the low reading. This is obviously undesirable.

NOTE 13—Use the manufacturer's instruction manual for the hydrogen test. This test is considered satisfactory if the reading agrees with the theoretical value within 0.3 %.

9. Operation and Checking of Apparatus

9.1 The recording calorimeter is designed for continuous operation and, as a precision instrument, it should receive regular inspection. Recording the results of tests, the replacement of any parts, and the establishment of a regular inspection will ensure that the high degree of precision attainable will be maintained. The manufacturer's appropriate instruction book gives details of the procedure for operating the instrument. The following points should be checked periodically:

9.1.1 *Recorder*—Check the operation of the recorder at regular intervals to be sure that the chart is set at the proper time and that the pen is making a satisfactory line. Examinations of the chart record will aid in avoiding certain operating problems since the record will show if undesirable conditions develop. For example, an irregular chart may be the result of deposits in the burner parts or on orifice caps. Gradual changes in the record from normal values may indicate a failure to replenish the water in the reserve tank or may show the existence of obstructions on the overflow weir.

9.1.1.1 *SMART-CAL*—The paper in the printer should be checked weekly. It may be necessary to correct the time. If alarm lights such as "high," "low," "max deviation," or "flame out" are activated, the operator will check the tank unit for water level, flame out, dirty overflow weir, restricted combustion air flow, defective burner parts, and so forth.

9.1.2 *Tank Unit*—To avoid contamination of the air in the room with combustible gas, take care to ensure that the bleeder burner remains lighted at all times. For unattended locations, a thermostatically operated shutoff valve that closes upon failure of the bleeder flame is normally provided. Regular inspection will indicate the necessity of replenishing the water in the reserve tank and thus ensure maintenance of the proper level in the main tank. The presence of any foreign material either in or

on the water can be avoided by regular examination. This will prevent incorrect overflow weir operation. Periodic examination of the thermometers and the burner parts will avoid errors in reading which could be caused by deterioration of any of these parts.

10. Procedure for Cold Balance Test

10.1 For the Recorder When Used:

10.1.1 The object of the cold balance test is to check the complete temperature-measuring circuit. It is equivalent to the calorimeter measuring a gas with zero heating value. For this test, observe the same precautions and care that are required for the calorimeter in normal use. The overall time of test shall not be less than 1 h.

10.1.2 If the cold balance is consistent within the range of the balancing rheostat (only small variations occurring from one test to another), the thermometer leads and resistance elements in the circuit are in satisfactory condition.

10.1.3 The rheostat provides a small amount of adjustment to compensate for any differences in the resistance of the thermometer leads. Thus, variations in the setting could be evidence of unsatisfactory electrical connections or deterioration of the thermometers or connecting leads.

10.1.4 When performing the test, it is very important that the room temperature be stable to avoid a false balance condition. In effect, a falling room temperature tends to result in a low-balance setting and a rising room temperature in a high-balance setting. The room temperature variation shall not exceed $\pm 2.5^\circ\text{F}$ during this test.

10.2 For SMART-CAL When Used:

10.2.1 The object of the cold balance test is to check the complete temperature measuring circuit and the electrical calibration of the SMART-CAL using internal test circuitry described in 10.2.2. This test is performed with the tank unit running. Stabilization time would be the same as specified in 10.1.1.

10.2.2 The cold balance and span adjustments are made when the SMART-CAL is in the calibration mode. Using the keyboard, the operator should activate the low-range display. This value is adjusted using the cold balance screw on front. Then the high-range display is activated. It is then set to the correct value using the span screw on the top of the instrument. The correct low- and high-range values are specified on a calibration plate on the front of the instrument. These values are a function of the heating value range, the thermometer pair used, and the basis of measurement.

11. Procedure for Air-Gas Ratio Test

11.1 The object of the air-gas ratio test is to ensure the fixed predetermined volume relation between the output of the gas meter and that of the heat-absorbing air meter. This volume ratio is a basic factor in the accuracy of the calorimeter.

11.2 The room temperature shall be reasonably constant at the normal controlled value during the test.

11.3 The tank unit shall be in proper mechanical operating condition; particularly, there should be no excessive gear or bearing wear existing.

11.4 Accurately balance the air-gas ratio prover. (See new model setup, Fig. 5.)

11.5 There shall be no leaks in the gas meter, heat-absorbing air meter, or the prover and its connections.

11.6 Check the tank unit level before the air-gas ratio test is started.

11.7 Recording of a typical air-gas ratio test is shown in Table 2 with the allowable tolerances.

12. Standardization of Calorimeter

12.1 The overall accuracy of the recording calorimeter may be checked by burning a gas of known heating value and comparing the results with this value. The total time of test

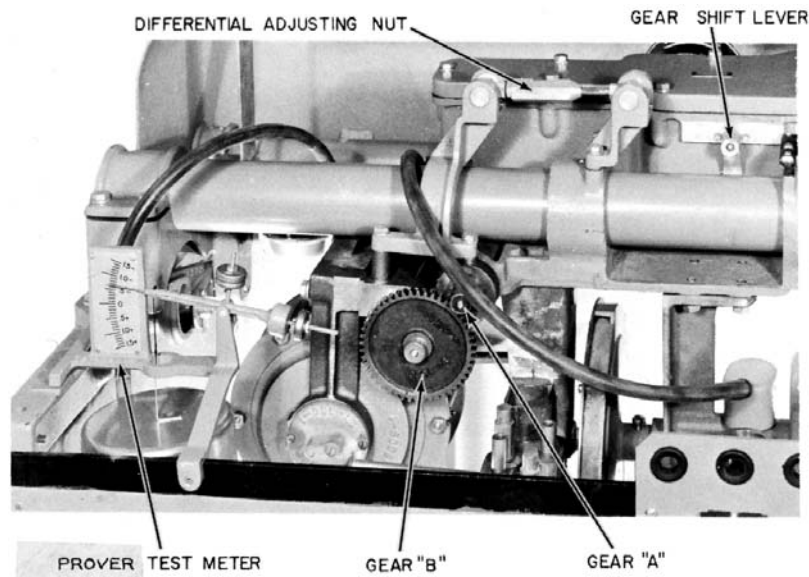

FIG. 5 Air-Gas Ratio Prover