



Designation: **C1589/C1589M – 17** C1589/C1589M – 17a

## Standard Practice for Outdoor Weathering of Construction Seals and Sealants<sup>1</sup>

This standard is issued under the fixed designation C1589/C1589M; the number immediately following the designation indicates the year of original adoption or, in the case of revision, the year of last revision. A number in parentheses indicates the year of last reappraisal. A superscript epsilon ( $\epsilon$ ) indicates an editorial change since the last revision or reappraisal.

### 1. Scope

1.1 This practice describes outdoor exposure procedures to be used as part of a test designed to determine the weatherability of building construction, seals and sealants.

NOTE 1—See Practice **G24** for Exposures to Daylight Filtered Through Glass.

1.2 This practice includes three procedures for outdoor weathering. Procedure A exposes specimens to outdoor weathering without movement. Procedure B and Procedure C are, respectively, continuous natural and periodic manual techniques for subjecting specimens to the combination of cyclic movement and exposure to outdoor weathering.

1.3 This practice is limited to the method by which the construction seals or sealants are exposed to outdoor weathering as part of a test program. It refers to the types of evaluations to be performed following the outdoor exposure but does not describe the test methods.

1.4 Means of evaluation of the effects of weathering will depend on the intended use of the test material.

1.5 The values stated in either SI units or inch-pound units are to be regarded separately as standard. The values stated in each system may not be exact equivalents; therefore, each system shall be used independently of the other. Combining values from the two systems may result in non-conformance with the standard.

1.6 *This standard does not purport to address all of the safety concerns, if any, associated with its use. It is the responsibility of the user of this standard to establish appropriate safety and health practices and determine the applicability of regulatory limitations prior to use.*

1.7 *This international standard was developed in accordance with internationally recognized principles on standardization established in the Decision on Principles for the Development of International Standards, Guides and Recommendations issued by the World Trade Organization Technical Barriers to Trade (TBT) Committee.*

### 2. Referenced Documents

[ASTM C1589/C1589M-17a](#)

<https://standards.cerif.org/catalog/standards/sist/67d1fb09-2ec7-4461-a51e-1cd343e2f578/astm-c1589-c1589m-17a>

**C717 Terminology of Building Seals and Sealants**

**C719 Test Method for Adhesion and Cohesion of Elastomeric Joint Sealants Under Cyclic Movement (Hockman Cycle)**

**C1135 Test Method for Determining Tensile Adhesion Properties of Structural Sealants**

**C1735 Test Method for Measuring the Time Dependent Modulus of Sealants Using Stress Relaxation**

**E631 Terminology of Building Constructions**

**E772 Terminology of Solar Energy Conversion**

**G7 Practice for Atmospheric Environmental Exposure Testing of Nonmetallic Materials**

**G24 Practice for Conducting Exposures to Daylight Filtered Through Glass**

**G84 Practice for Measurement of Time-of-Wetness on Surfaces Exposed to Wetting Conditions as in Atmospheric Corrosion Testing**

**G113 Terminology Relating to Natural and Artificial Weathering Tests of Nonmetallic Materials**

**G147 Practice for Conditioning and Handling of Nonmetallic Materials for Natural and Artificial Weathering Tests**

**G169 Guide for Application of Basic Statistical Methods to Weathering Tests**

**G178 Practice for Determining the Activation Spectrum of a Material (Wavelength Sensitivity to an Exposure Source) Using the Sharp Cut-On Filter or Spectrographic Technique**

<sup>1</sup> This practice is under the jurisdiction of ASTM Committee **C24** on Building Seals and Sealants and is the direct responsibility of Subcommittee **C24.40** on Weathering. Current edition approved Feb. 1, 2017; March 15, 2017. Published March 2017/April 2017. Originally approved in 2004. Last previous edition approved in 2016/2017 as C1589/C1589M-16-17. DOI: 10.1520/C1589/C1589M-17-10.1520/C1589/C1589M-17A.

<sup>2</sup> For referenced ASTM standards, visit the ASTM website, www.astm.org, or contact ASTM Customer Service at service@astm.org. For *Annual Book of ASTM Standards* volume information, refer to the standard's Document Summary page on the ASTM website.

### 3. Terminology

3.1 *Definitions*—Definitions are found in Terminologies C717, G113, E631, and E772.

### 4. Significance and Use

4.1 Tests conducted in accordance with this practice are used to evaluate the weatherability of construction seals and sealant materials when they are exposed to outdoor weather conditions. The weatherability of seals and sealants in actual outdoor use can be very different depending on the location because of differences in solar radiation, moisture, temperature, pollutants, and other factors. Sealant color may also affect weatherability.

4.2 This practice allows for three options: Option 1 – Procedure A in which the effect of movement during weathering is not considered; Option 2 – Procedure B in which specimens are weathered in conjunction with movement based on thermal changes. The applied strain is proportional to a combination of the temperature at the time the equipment is set up and subsequent thermal changes. This option closely mimics the actual movements that occur in many sealant installations, but is less repeatable than the movement in Procedure C; Option 3 – Procedure C in which the strain during weathering is manually applied. This procedure allows for excellent control and repeatability, but is less representative of movement in actual use conditions than the movement in Procedure B. Options 2 and 3 have been added to this practice based on peer reviewed scientific literature demonstrating that applied strain separately and in combination with other weathering stresses causes changes in the weatherability of sealants.

4.3 The type, frequency and amount of movement of sealants varies with location and may affect weatherability. It cannot be assumed, therefore, that results from one exposure in a single location will be useful for determining weatherability in a different location. Exposures in several locations with different climates (for example, solar radiation, moisture, temperature, pollutants, biological and other factors) that represent a broad range of anticipated service conditions are recommended.

4.4 It is strongly recommended that control materials of similar composition and construction to the test specimens and with known weatherability be exposed along with the test specimens for the purpose of comparing the performance of test materials to the controls. (See 6.2).

4.5 The results of short-term exposure tests can provide an indication of relative outdoor performance, but they shall not be used to predict the absolute long-term performance of a seal or sealant material. The results of tests conducted for less than 12 months will depend on the particular season of the year in which they begin.

4.6 Because of year-to-year climatological variations, results from a single exposure test cannot be used to predict the absolute rate at which a seal or sealant degrades. Several years of repeat exposures are needed to determine an average test result for a given location.

4.7 Climatic and construction factors can impose cyclic movement upon sealed joints in use. This movement can impact the effects of outdoor weathering and often causes types of failure that are not produced by weathering without movement. Thus, the ability of building joint sealants to withstand temperature-induced movements of compression and expansion is an important property.

4.8 Outdoor weathering of specimens in combination with natural or forced cyclic movement during exposure can provide a more realistic assessment of the ability of a seal or sealant to withstand the combined effects of climate and movement encountered by seals and sealants in building construction applications.

### 5. Test Sites and Exposure Racks

5.1 The test site shall conform to the requirements of Practice G7, and preferably, samples should be tested at a suitable number of climatologically different sites representing the variable conditions under which the construction seal or sealant will be used. Climatological variations within these areas may include those represented by desert, seashore (salt air), industrial locations, tropical, and subtropical regions, plus areas exhibiting a wide range of solar radiant energy. The area beneath and in the vicinity of the weathering racks shall be typical of the ground cover in that climatological area. In desert areas in which sand is the prevailing ground cover, coarse gravel is required to prevent abrasion and significant dust accretion due to wind-blown sand (Note 2). The ground cover shall be low-cut grass in most temperate, tropical, and subtropical areas.

NOTE 2—Sand as a ground cover may be desirable where the abrasive effects of exposure to wind-blown sand is a part of the desired exposure.

5.2 Weathering test racks shall be located in cleared areas. The racks and hardware shall conform to the requirements of Practice G7 and shall provide for the attachment of specimens or holders of any appropriate width and length. The structural members of the test racks shall not constitute a backing to the specimens under test. Fasteners used to attach specimens to the test rack shall provide for secure attachment but allow specimens to expand or contract with thermal changes, moisture absorption or desorption, or plasticizer loss.

5.3 Unless otherwise specified, position the racks at 45° relative to horizontal, facing the equator. The angle of the exposure rack, and the orientation relative to the equator can vary depending upon the in-service application of the material. Consult Practice G7 for information on other exposure rack orientations. If other rack orientations are used they must be reported.

## 6. Test Specimens

6.1 Follow the manufacturer's instructions for mixing or preparing, or both, materials to be tested. The specimens shall be cured under standard conditions as defined in Terminology **C717**. As far as practical, test specimens shall simulate those used in service conditions of an end-use application. When conditions of use are known, the specimen exposed will consist of seal or sealant material being evaluated plus suitable substrate or installation materials to conform to the projected practice. The effect of substrate or installation materials is highly significant and contributes to the degradation due to reflectance, heat absorption, moisture retention, etc.

6.2 It is recommended that a similar material of known performance under use conditions (a control) be exposed simultaneously with the test specimen for evaluation of the performance of the test materials relative to that of the control. It is preferable to use two control materials, one with relatively poor weatherability and the other with good weatherability. It is strongly recommended that control materials and test materials be of the same dimensions.

6.3 The use of at least three replicate specimens of each experimental and control material being tested is recommended in order to allow for variability. Consult Guide **G169** for performing statistical analysis.

6.4 The total number of specimens will be determined by the number of exposure periods, number of replicates exposed, and the number of unexposed file specimens. When destructive tests are used to evaluate the effect of weathering, ensure that sufficient unexposed file specimens are retained to be tested each time the exposed materials are tested. These unexposed file specimens shall be retained at conditions of  $23.0 \pm 2^\circ\text{C}$ . They shall be covered with inert opaque wrapping to exclude light during the storage period.

6.5 Refer to Practice **G147** for procedures on specimen identification, handling and conditioning.

## 7. Specimen Holders

7.1 Specimen holders shall be used to support the specimens. In no case shall the specimen holder constitute a backing for that portion of the material to be evaluated.

7.2 The specimen holders shall be constructed of a material agreed upon by the mutual parties.

## 8. Instruments for Measuring Climatological Data

8.1 *Instruments Used to Measure Ambient Temperature and Relative Humidity*—Instrument and procedures used for measurement of ambient temperature and relative humidity shall be in accordance with Practice **G7**.

8.2 *Instruments Used to Measure Solar Radiation*—Instrument and calibration procedures used for measurement of total solar radiation, total solar ultraviolet radiation, or narrow band solar ultraviolet radiation shall be in accordance with Practice **G7**.

## 9. General Procedure

9.1 Mark the test specimens to be exposed with an identifying number, letter, or symbol so that they may be identified readily after exposure. The marking shall be such that there is no interference with either the exposure or the subsequent testing. (Preferably, mark both specimen and specimen holder on the side not exposed to weather, as extended exposure can obscure even deeply scribed marks.)

9.2 Record the initial appearance and physical-property data appropriate to the evaluation method used.

9.3 Mount the test specimens in the holder or directly to the exposure rack. It is convenient to group specimens to be removed from exposure at the same time in one holder.

9.4 Record a diagram of the test specimen holder layout, and record the date of installation and length of exposure planned.

9.5 Ensure that the pyranometer is mounted at a tilt and azimuth angle that is identical to that of the test specimens.

9.6 Mount the specimens on racks for the prescribed time, solar radiant energy, or total UV radiant energy or narrow band UV radiant energy.

9.7 Establish a fixed procedure of cleaning, visual examination, conditioning, and testing of the specimens. This procedure will vary with materials, but it must be uniform in a series of tests on one material to provide comparative results.

9.8 The face of the specimen shall not be masked for the purpose of showing the effects of various exposure times on one panel. Misleading results can be obtained by this method since the masked portion of the specimen is still exposed to temperature and humidity that will affect the results in many cases.

9.9 Unexposed file specimens shall be used for visual comparison to exposed specimens and for destructive tests compared with those of exposed specimens at various exposure stages.

9.10 Exposures and evaluations shall be planned to permit reporting one of the following for the test material(s) and control(s), if used:

9.10.1 Change after a specified exposure,

9.10.2 Amount of time for a specified change in properties to occur, and

9.10.3 A record of measurements after various exposure periods.

## 10. Exposure Procedures With and Without Movement

### 10.1 Procedure A—Outdoor Weathering Without Movement

#### 10.1.1 Test Specimens:

10.1.1.1 Test specimens may be of any size or shape that can be mounted in a fixture, a holder or applied directly to the racks. The specimen dimensions can either be suited to the methods of evaluating the effects of weathering on specific properties, or larger from which smaller specimens for evaluation are cut. The exposure test specimens shall be large enough to allow for removal of the mounting edges, which would affect the evaluation of test results.

10.1.1.2 Test specimens can be made with any substrate. Standard substrates are glass, aluminum and concrete.

#### 10.1.2 Apparatus:

10.1.2.1 Test racks and hardware shall conform to the requirements of Practice **G7** and shall provide for the attachment of specimens or holders of any convenient width and length. The structural members of the test racks shall not constitute a backing to the specimens under test.

10.1.2.2 Specimen holders shall be used to support the many sizes of specimens involved in this testing. The specimen holders shall be constructed of a material agreed upon by the mutual parties. Aluminum panels, glass, and marble shapes have been found suitable for static exposures. In no case shall the specimen holder constitute a backing for that portion of the material to be evaluated.

10.1.2.3 Fasteners used to attach specimens to the test rack shall provide for secure attachment but allow specimens to expand or contract with thermal changes, moisture absorption or desorption, or plasticizer loss.

### 10.2 Procedure B—Outdoor Weathering of Building Joint Sealants With Continuous Movement

#### 10.2.1 Significance and Use:

10.2.1.1 The ability of building joint sealants to withstand daily and annual cycles of extension (tension) and compression caused by variations in the temperature of the sealants is an important property. This procedure defines a means of imposing temperature-induced cyclic movement of varying strain levels to specimens during exposure to outdoor weathering elements. The procedure applies to specimens whose size complies with the dimensions described in Test Method **C719**.

10.2.1.2 The extensions and compressions due to the pipe-induced movements will vary because of the daily and seasonal variations in ambient temperature and, most of the time, the extensions and compressions will be less than that of the full rated movement. However, the pipe-induced movement can produce weathering effects that more closely simulate in-service weathering than tests without movement.

**NOTE 3**—The device can be modified to obtain various levels of cyclic movement by changing the length of the pipe in consideration of the local weather conditions. The strain level imposed on the sealant will also depend on the temperature at the beginning of the experiment. For example, if the sealant exposure is started (zero level) on the hottest day of the year, all other temperatures will give either compression or tension depending on the design of the instrument. It is typically assumed that most sealant installations receive a balance of tension and compression during the year. Typical daily strains will be much less than the rated movement of the sealant. It is the seasonal changes in combination with the daily cycles that produce strains near the rated movement of the sealant.

10.2.1.3 The loss of sealant properties caused by this procedure depends on the season of the exposure and geographical location. Therefore, it cannot be assumed that a single exposure test can be used to predict the absolute rate at which loss of sealant properties occurs at one exposure site or to predict sealant property loss in a different location.

10.2.2 *Apparatus*—For additional details on description of equipment, see C. C. White, et. al, Review of Scientific Instruments, 82, 025112 (2011).<sup>3</sup> A detailed description of the apparatus is also included in an ASTM Research Report.<sup>4</sup> Note that the apparatus described is only for 25 % movement in Gaithersburg, MD. The length of the pipe will differ for different movement classes or a different location.

10.2.2.1 *Exposure Rack*—The exposure rack shall consist of specimen holders, a fixed supporting frame, a movable frame and polyvinyl chloride (PVC) pipes, see **Fig. 1a**. It employs the difference in the coefficients of thermal expansion between the fixed supporting frame and PVC pipes to induce strain on sealant specimens.

10.2.2.2 *Specimen Holder*—The specimen holders shall be used to support the specimen geometry conforming to Test Method **C719**. They shall be constructed of a material agreed upon by mutual parties (aluminum alloy and stainless steel have been found suitable for this application) and consist of two U-shaped metal holders (**Fig. 1b**). The specimens of a material are placed inside the U-shaped holders, and two thumbscrews at the bottom of each U-shaped holder are used to hold the specimens in place. The specimen holders are attached to the stainless steel fixed supporting and movable frames using stainless steel rods so that at a high temperature, the PVC pipe expands causing specimen to be loaded in compression; while at a low temperature, the specimen will be loaded in extension (tension) (**Fig. 2**). The ends of the stainless steel rods are all threaded (M6 × 1 – this specifies the screw

<sup>3</sup> Available from <http://rsi.aip.org/>

<sup>4</sup> Supporting data have been filed at ASTM International Headquarters and may be obtained by requesting Research Report RR:C24-1062. Contact ASTM Customer Service at [service@astm.org](mailto:service@astm.org).

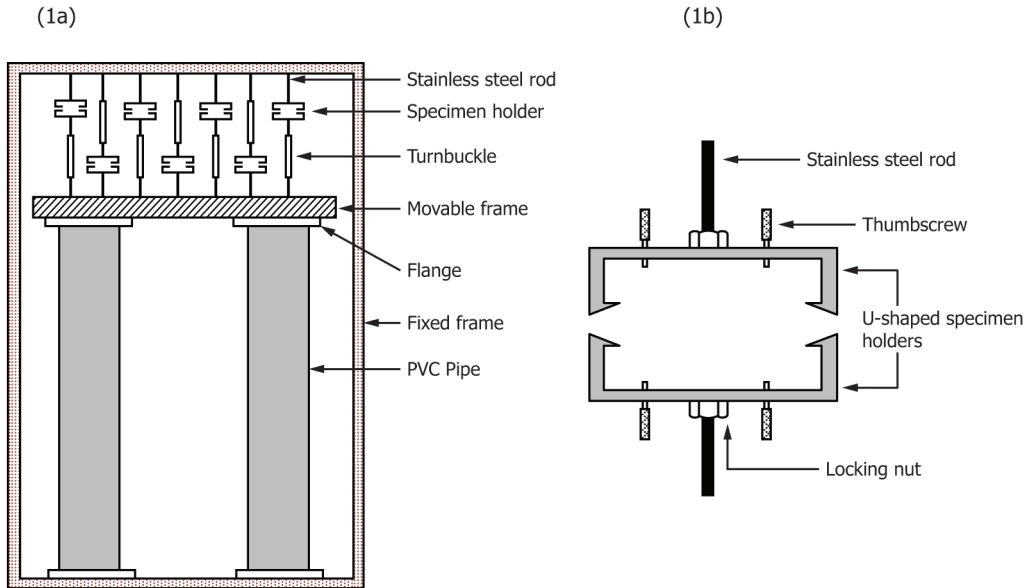
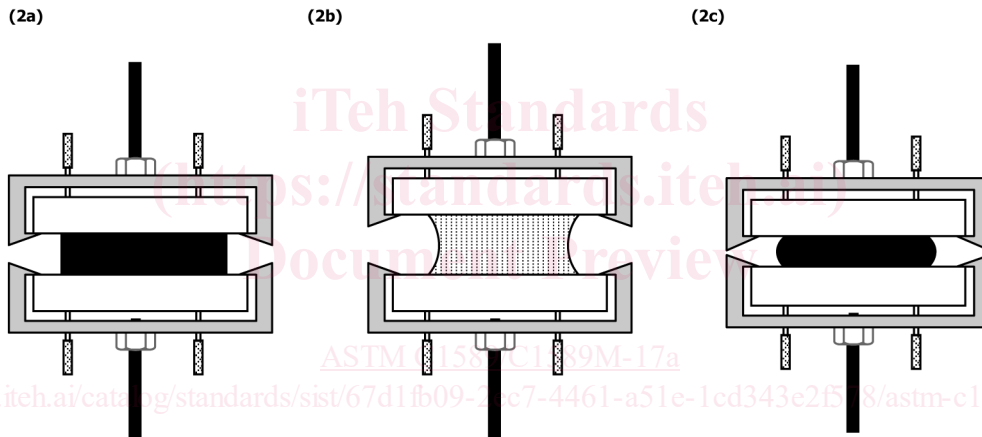

FIG. 1 (a) Schematic of Exposure Rack and (b) Specimen Holder (not to scale)



(a) at the intermediate temperature, the specimen is stress-free, (b) at a temperature below the intermediate temperature, the PVC pipes contract putting the specimen in extension (tension) and (c) at a temperature above the intermediate temperature, the PVC pipes expand causing the specimens to be in compression.

FIG. 2 Schematic of the Effect of Temperature on Movement of the Specimens (not to scale)

size and thread). In the middle of one of the rods between frame and specimen holders is a turnbuckle barrel for adjusting the length of the rod, and hence the extension (tension) of the specimen. All the connections are tightened using locking nuts (M6 × 1).

10.2.2.3 *Fixed Supporting and Movable Frames*—The support of the fixed frame shall be made of a material that is dimensionally insensitive to thermal variation. Hardwood (with cellulose fibers placed in the longitudinal directions) have been shown to be an effective, dimensionally temperature insensitive, material.

10.2.2.4 *PVC Pipes*—(These specifications only apply to materials rated for maximum strain of ±25 % and tested in the Gaithersburg, MD area) – Two 101.6 mm [4 in.] diameter PVC pipes are used and their coefficient of thermal expansion, CTE, must be known or measured. Toilet flanges are used to attach the PVC pipes at the bottom to the fixed supporting frame and at the top to the movable frame. The length of the PVC pipe,  $L$ , which meets the requirement of imposing ±25 % cyclic movement on specimens, is calculated as follows:

$$L = \frac{\Delta L}{CTE \times (T_{\max} - T_{\min})} \quad (1)$$

where:

$L$  = length of PVC pipe, m [in.],

$\Delta L$  = total of movement of pipe between  $T_{\max}$  and  $T_{\min}$ , m [in.]:  $\Delta L = 6.35 \times 10^{-3}$  m or  $[\Delta L = 0.25 \text{ in.}]$ ,

$CTE$  = coefficient of thermal expansion,  $^{\circ}\text{C}^{-1}$  [ $^{\circ}\text{F}^{-1}$ ],

$T_{\max}$  = maximum temperature extreme expected in the exposure site,  $^{\circ}\text{C}$  [F],

$T_{\min}$  = minimum temperature extreme expected in the exposure site, °C [F].

10.2.3 *Specimen Thickness Change*—In implementing the requirement of the  $\pm 25\%$  strain limit for the 12.7 mm [0.5 in.] Test Method C719 specimen, note first that specimen thickness needs to change from 9.525 mm [0.375 in.] at the maximum temperature extreme ( $T_{\max}$ ) expected at the exposure site to 15.875 mm [0.625 in.] at the corresponding minimum temperature extreme ( $T_{\min}$ ), spanning a total movement of 6.35 mm [0.25 in.].

10.2.4 *Test Procedure:*

10.2.4.1 Ensure that the specimens are inscribed or otherwise labeled with an identifying number, letter or symbol. Specimen marking shall be in accordance with Practice G147 and shall be such that there is no interference with either the exposure or the subsequent testing.

10.2.4.2 Measure the initial physical properties of unexposed specimens. Typical properties measured are time-dependent moduli (in accordance with Test Method C1735) and visual appearance for any abnormalities, such as cracks, crazing, tears, and adhesion flaws.

10.2.4.3 Mount the specimens to be exposed to the specimen holders at the intermediate temperature,  $T$ , between the maximum and minimum temperature extremes expected in the exposure site. Exercise precautions to minimize axial misalignment. This intermediate temperature corresponds to the temperature at which the specimens are stress-free.

$$T = \frac{T_{\max} + T_{\min}}{2} \quad (2)$$

where:

$T$  = intermediate temperature between  $T_{\max}$  and  $T_{\min}$ .

10.2.5 *Evaluation of Exposure of Specimens:*

10.2.5.1 After specimens are exposed for the desired amount of time, solar radiant energy, total ultraviolet radiant energy, or narrow band ultraviolet radiant energy, inspect the specimen to note the locus of joint failure, if any failure occurs.

10.2.5.2 Measure the properties of exposed specimens using the test methods as specified in 10.2.4.2.

10.3 *Procedure C—Outdoor Weathering of Building Joint Sealants with Periodic Manual Extension and Compression*

10.3.1 *Test Specimens:*

10.3.1.1 The procedures for making test specimens, including their cures, number of specimens (replicates) for each test, the specimen dimensions, and the substrate preparation shall conform to the descriptions in Section 7 of Test Method C719. (See Also C719 for exact dimensions and procedures for making specimens.) make an extra specimen for each set that will be kept at standard conditions (no outdoor exposure), but subjected to the same movement cycles as the other specimens. The sealant curing for all specimens shall be 28 days at standard conditions.

NOTE 4—Longer curing than specified in Test Method C719 is necessary to ensure that the sealant's properties have developed sufficiently to withstand the sustained extension or compression.

10.3.1.2 Test specimens can be made with any substrate. Standard substrates are glass, aluminum and concrete as per Test Method C719.

NOTE 4—Variations in joint geometry are permitted, with the most common being joints that have a 2:1 width-to-depth ratio (such as 12 mm [0.47 in.] wide and 6 mm [0.23 in.] deep). This default design conforms to most of the manufacturer's recommendations for joint design.

10.3.1.3 The design of the specimen holders intended to allow for cyclic movement (for example, testing rigs and manually adjusted vices) shall be agreed upon by the mutual parties.

10.3.2 *Apparatus*—Apparatus: Any clamping device can be used to hold specimens. An example of such a device is shown in Fig. 3 and Fig. 4 for holding the specimen in compression and extension, respectively. Use 114.3 mm [4½ in.] aluminum (or stainless steel) bars drilled with holes near ends, near the top, with 101.6 mm [4 in.] bolts and nuts to secure them. Use a bead of sealant 50.8 mm by 0.15 m by 6.35 mm [2 in. by ½ ft by ¼ in.] placed in between and appropriate spacer blocks to ensure the test specimen is held at the desired extension or compression or neutral position.

10.3.2.1 Specimens are attached to the exposure rack by any convenient method. Any clamping device can be used to hold specimens. An example of specimens attached to a south facing test track such a device for holding a specimen in tension or compression is shown in Fig. 53: and Fig. 4, respectively. Use 114.3 mm [4½ in.] aluminum (or stainless steel) bars drilled with holes near ends, near the top of the device, with 101.6 mm [4 in.] bolts and nuts to secure the bars. Insert a pair of casting spacers (such as nylon blocks) to ensure the test specimen is held at the desired neutral dimensions. Provide one pair of separators for each specimen for the extension dimension and one pair of separators for each specimen for the compression during the movement cycles.

10.3.2.2 Construct an outdoor exposure rack to hold the specimens; and example rack is shown in Fig. 5. Use hardware cloth or similar open-lattice backing to support the specimens without acting as a heat sink or reflector. Ensure that the rack is rigid enough that the specimens do not deflect the supporting material, changing their exposure angle. Orient the rack facing the equator and at an altitude angle of 45 degrees.