



Designation: **E238 – 12 E238 – 17**

Standard Test Method for Pin-Type Bearing Test of Metallic Materials¹

This standard is issued under the fixed designation E238; the number immediately following the designation indicates the year of original adoption or, in the case of revision, the year of last revision. A number in parentheses indicates the year of last reapproval. A superscript epsilon (ϵ) indicates an editorial change since the last revision or reapproval.

1. Scope*

1.1 This test method covers a pin-type bearing test of metallic materials to determine bearing yield strength and bearing strength.

NOTE 1—The presence of incidental lubricants on the bearing surfaces may significantly lower the value of bearing yield strength obtained by this method.

1.2 *Units*—The values stated in inch-pound units are to be regarded as standard. The values given in parentheses are mathematical conversions to SI units that are provided for information only and are not considered standard.

1.3 *This standard does not purport to address all of the safety concerns, if any, associated with its use. It is the responsibility of the user of this standard to establish appropriate safety and health practices and determine the applicability of regulatory limitations prior to use.*

1.4 *This international standard was developed in accordance with internationally recognized principles on standardization established in the Decision on Principles for the Development of International Standards, Guides and Recommendations issued by the World Trade Organization Technical Barriers to Trade (TBT) Committee.*

2. Referenced Documents

2.1 *ASTM Standards:*²

[E4 Practices for Force Verification of Testing Machines](#)

[E6 Terminology Relating to Methods of Mechanical Testing](#)

[E83 Practice for Verification and Classification of Extensometer Systems](#)

[B769 Test Method for Shear Testing of Aluminum Alloys](#)

[B831 Test Method for Shear Testing of Thin Aluminum Alloy Products](#)

3. Terminology

3.1 *Definitions:*

3.1.1 *bearing area*—the product of the pin diameter and specimen thickness.

3.1.2 *bearing stress*—the force per unit of bearing area.

3.1.3 *bearing strain*—the ratio of the bearing deformation of the bearing hole, in the direction of the applied force, to the pin diameter.

3.1.4 *bearing yield strength*—the bearing stress at which a material exhibits a specified limiting deviation from the proportionality of bearing stress to bearing strain.

3.1.5 *bearing strength*—the maximum bearing stress which a material is capable of sustaining.

3.1.6 *edge distance*—the distance from the edge of a bearing specimen to the center of the hole in the direction of applied force ([Fig. 1](#)).

3.1.7 *edge distance ratio*—the ratio of the edge distance to the pin diameter.

3.1.8 For definitions of other terms see Terminology [E6](#).

¹ This test method is under the jurisdiction of ASTM Committee [E28](#) on Mechanical Testing and is the direct responsibility of Subcommittee [E28.04](#) on Uniaxial Testing. Current edition approved ~~June 1, 2012~~ Feb. 1, 2017. Published ~~August 2012~~ April 2017. Originally approved in 1964. Last previous edition approved in ~~2008~~ 2012 as ~~E238 – 84 (2008)~~ E238 – 12. DOI: ~~10.1520/E0238-12~~ 10.1520/E0238-17.

² For referenced ASTM standards, visit the ASTM website, www.astm.org, or contact ASTM Customer Service at service@astm.org. For *Annual Book of ASTM Standards* volume information, refer to the standard's Document Summary page on the ASTM website.

*A Summary of Changes section appears at the end of this standard

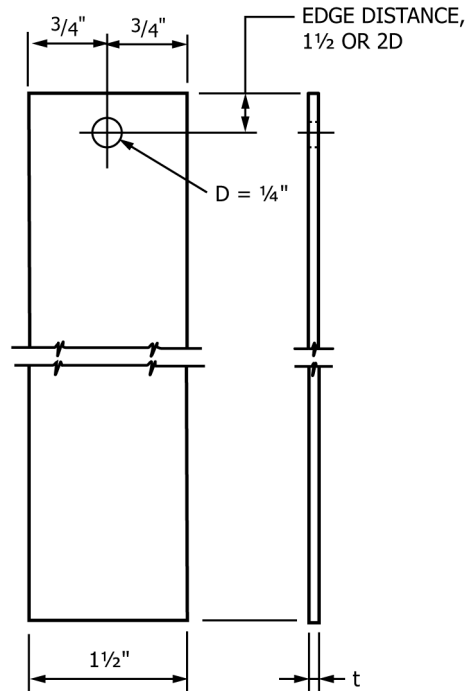

FIG. 1 Bearing Test Specimen

TABLE 1 Characteristics of Pin for Various Materials Tested

Material Tested	Material	Rockwell Hardness	Surface Roughness, μ in. (μ m) (avg)
Aluminum alloys	hardened steel	C60 to 64	4 to 8 (0.1 to 0.2 μ m)
Beryllium alloys	hardened steel	C60 to 64	4 to 8 (0.1 to 0.2 μ m)
Copper alloys	hardened steel	C60 to 64	4 to 8 (0.1 to 0.2 μ m)
Magnesium alloys	hardened steel	C60 to 64	4 to 8 (0.1 to 0.2 μ m)
Zinc alloys	hardened steel	C60 to 64	4 to 8 (0.1 to 0.2 μ m)

ASTM E238-17

4. Significance and Use

4.1 The data obtained from the bearing test are the bearing ultimate and yield strength. The data provide a measure of the load-carrying capacity of a material edge loaded with a close-fitting cylindrical pin through a hole located a specific distance from the specimen edge.

4.2 Bearing properties are useful in the comparison of materials and design of structures under conditions where the pin is not restricted.

5. Apparatus

5.1 *Testing Machines*—Machines used for bearing testing shall conform to the requirements of Practices E4.

5.2 *Gripping Devices*—Various types of gripping devices may be used to transmit the measured load applied by the testing machine to the test specimens. Any grips considered to apply the load axially for tension testing, such as pin connections or wedge grips, are satisfactory for use in bearing testing.

5.3 *Pin*—The bearing load is generally applied to the specimen through a close-fitting cylindrical pin. The pin shall be harder and stronger than the material being tested. Restraint of movement of the specimen where it is in contact with the pin has a considerable effect upon the hole deformation obtained as a function of the load applied. Close control of surface conditions on both the specimen and pin is needed to assure reproducible results. The pins used should be uniform in diameter, hardness, and surface roughness. Pin materials, hardness, and surface roughness as shown in Table 1 are recommended for testing the materials listed. The pin should be checked carefully after each test to ensure that no metallic residue adheres to it and that it is both straight and undeformed. If there is any question regarding its quality it should be replaced.

5.4 *Pin Support*—The jig supporting the pin should position the pin concentric with the hole in the specimen. It should not restrain the thickening of the specimen as the load from the pin deforms the hole. Bending of the pin should be kept to a minimum by having the jig support the pin close to the specimen. Fig. 2 and Fig. 3 show examples of the types of jig that have been used and are considered satisfactory.

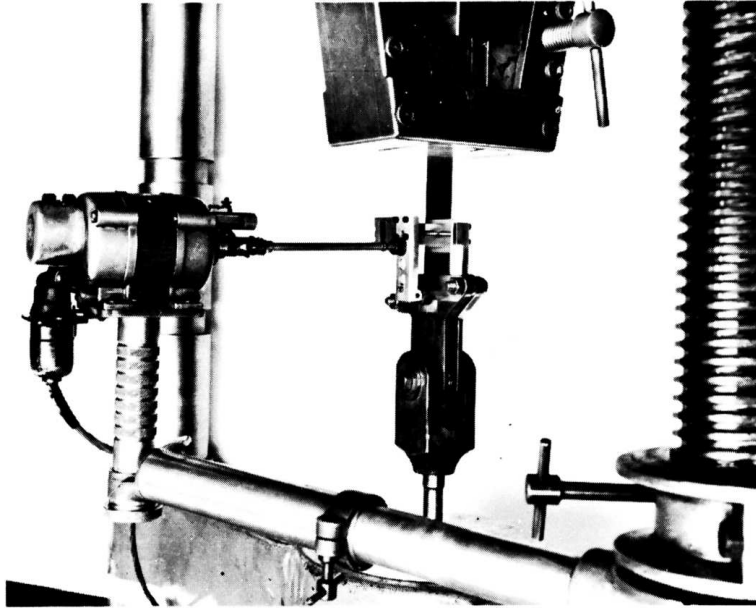

FIG. 2 Bearing Test Fixture Used on Aluminum Sheet

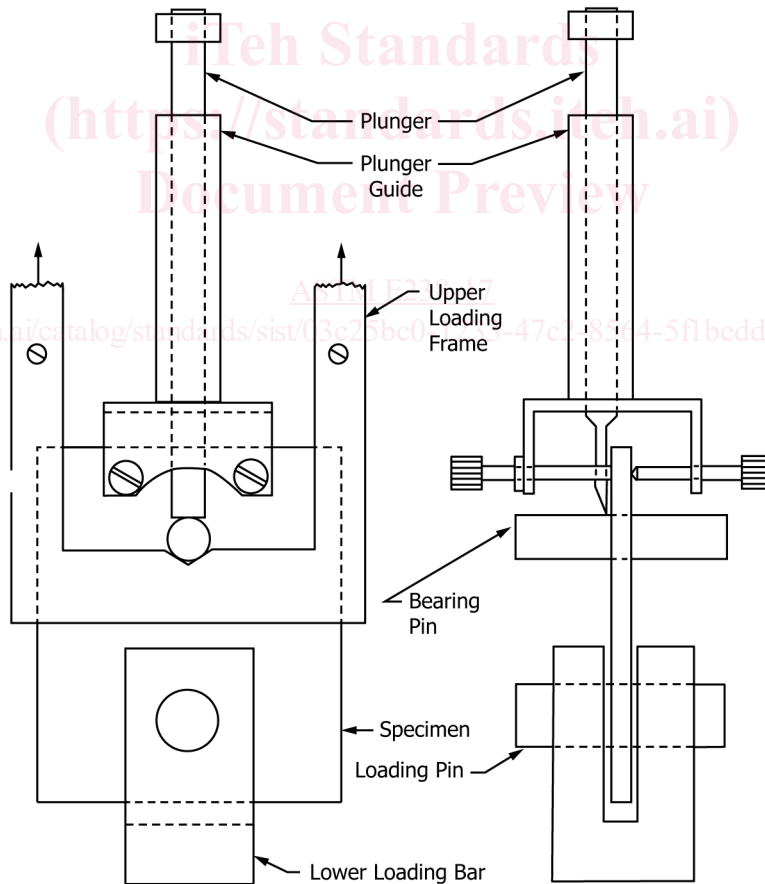

FIG. 3 Schematic Drawing of Bearing Deformation Transfer Device

5.5 *Extensometers*—Extensometers used for measuring the bearing deformation shall comply with the requirements for Class B-2 or better as described in Practice E83. The bearing deformation measurement shall be made in a manner to obtain the axial bearing deformation with a minimum of other deformations being included such as the bending of the pin and tensile strain in the