



# Standard Specification for Smooth-Wall Poly(Vinyl Chloride) (PVC) Conduit and Fittings for Underground Installation<sup>1</sup>

This standard is issued under the fixed designation F512; the number immediately following the designation indicates the year of original adoption or, in the case of revision, the year of last revision. A number in parentheses indicates the year of last reapproval. A superscript epsilon ( $\epsilon$ ) indicates an editorial change since the last revision or reapproval.

## 1. Scope\*Scope

1.1 This specification covers the requirements for single wall and coextruded cellular core smooth-wall poly(vinyl chloride) conduit and fittings for underground communication and electrical power wire and cables. Plastics which does not meet the material requirements specified in Section 5 is excluded from single layer and all coextruded layers.

1.2 The values given in parentheses are for information only.

1.3 The following safety hazards caveat pertains only to the test method portion, Section 8, of this specification: *This standard does not purport to address all of the safety concerns, if any, associated with its use. It is the responsibility of the user of this standard to establish appropriate safety and health practices and determine the applicability of regulatory limitations prior to use.*

1.4 *This international standard was developed in accordance with internationally recognized principles on standardization established in the Decision on Principles for the Development of International Standards, Guides and Recommendations issued by the World Trade Organization Technical Barriers to Trade (TBT) Committee.*

## 2. Referenced Documents

2.1 *ASTM Standards:*<sup>2</sup>

D618 Practice for Conditioning Plastics for Testing

D1600 Terminology for Abbreviated Terms Relating to Plastics

D1784 Specification for Rigid Poly(Vinyl Chloride) (PVC) Compounds and Chlorinated Poly(Vinyl Chloride) (CPVC) Compounds

D2122 Test Method for Determining Dimensions of Thermoplastic Pipe and Fittings

D2152 Test Method for Adequacy of Fusion of Extruded Poly(Vinyl Chloride) (PVC) Pipe and Molded Fittings by Acetone Immersion

D2412 Test Method for Determination of External Loading Characteristics of Plastic Pipe by Parallel-Plate Loading

D2444 Test Method for Determination of the Impact Resistance of Thermoplastic Pipe and Fittings by Means of a Tup (Falling Weight)

D2466 Specification for Poly(Vinyl Chloride) (PVC) Plastic Pipe Fittings, Schedule 40

D2564 Specification for Solvent Cements for Poly(Vinyl Chloride) (PVC) Plastic Piping Systems

D2855 Practice for the Two-Step (Primer and Solvent Cement) Method of Joining Poly (Vinyl Chloride) (PVC) or Chlorinated Poly (Vinyl Chloride) (CPVC) Pipe and Piping Components with Tapered Sockets

F412 Terminology Relating to Plastic Piping Systems

## 3. Terminology

3.1 Definitions are in accordance with Terminology F412 and abbreviations are in accordance with Terminology D1600, unless otherwise specified. The abbreviation for poly(vinyl chloride) is PVC.

3.2 *Definitions of Terms Specific to This Standard:*

3.2.1 *cellular plastic*—a plastic containing numerous cells, intentionally introduced, interconnecting or not, distributed throughout the mass.

<sup>1</sup> This specification is under the jurisdiction of ASTM Committee F17 on Plastic Piping Systems and is the direct responsibility of Subcommittee F17.25 on Vinyl Based Pipe.

Current edition approved Aug. 1, 2012 April 1, 2017. Published September 2012 April 2017. Originally approved in 1977. Last previous edition approved in 2006 2012 as F51206–12. DOI: 10.1520/F0512-12.10.1520/F0512-12R17.

<sup>2</sup> For referenced ASTM standards, visit the ASTM website, www.astm.org, or contact ASTM Customer Service at service@astm.org. For *Annual Book of ASTM Standards* volume information, refer to the standard's Document Summary page on the ASTM website.

\*A Summary of Changes section appears at the end of this standard

3.2.2 *coextruded pipe*—pipe consisting of two or more concentric layers of material bonded together in processing by any combination of temperature, pressure, grafting, cross-linking or adhesion.

3.2.3 *coextrusion*—a process whereby two or more heated or unheated plastic material streams, forced through one or more shaping orifice(s), become one continuously formed piece.

3.2.4 *external recycled material*—industrial rework generated by a different company manufacturing to this specification. Composition is known by the industrial source of the material.

3.2.5 *post-consumer recycled material*—finished goods that have been purchased by the public, then returned to industry and reprocessed into raw materials. Identity of finished goods is known by the reprocessing company.

3.2.6 *certificate of composition*—a certificate describing the certain properties of an external recycled material of a post consumer recycled material.

3.2.7 *composition disclosure*—a document describing the formulation of an external recycled material.

#### 4. Classification

4.1 This specification covers five types of underground conduit. There are two having lesser pipe stiffness values, designed primarily for concrete encased burial (EB), and three with greater pipe stiffness values, designed primarily for direct burial (DB). The complete designations follow:

Type EB-20	— Designed to be encased in concrete.
Type EB-35	— Designed to be encased in concrete.
Type DB-60	— Designed for direct burial without encasement in concrete.
Type DB-100	— Designed for direct burial without encasement in concrete.
Type DB-120	— Designed for direct burial without encasement in concrete.

4.2 This specification covers conduit with integral bells, or with either separate or attached couplings.

4.3 This specification covers molded and fabricated fittings intended for use with all types of conduit.

#### 5. Materials

5.1 *Basic Materials*—The conduit shall be made of virgin homopolymer PVC compound having a cell classification of 12254, 12164<sup>3</sup> (with a minimum tensile strength of 4000 psi (28 MPa)), or 12264 (with a minimum tensile modulus of 500 000 psi) as defined in Specification [D1784](#). Molded fittings shall be made from PVC compound having a cell classification of 12234 or 13343 as defined in Specification [D1784](#). Homopolymer PVC compounds must equal or exceed the requirements of the listed cell classification numbers.

5.2 *Rework Materials*—Rework material from the manufacturer's own conduit or fittings production may be used by the same manufacturer, provided that the conduit or fittings produced meet all of the requirements of this specification. Rework material from the manufacturer's coextruded cellular core conduit shall be used in the core if it contains any residual blowing agent. The pipe produced shall meet all of the requirements of this specification.

5.3 *Recycled PVC Materials*—Recycled PVC materials conforming to the cell classification of this specification may be used provided they are clean and free from foreign materials and provided that the conduit or fittings produced meet all requirements of this specification.

5.4 *Solvent Cement*—The solvent cement shall meet the requirements of Specification [D2564](#).

#### 6. Requirements

6.1 *Workmanship*—The conduit and fittings shall be homogeneous throughout, and free from visible cracks, holes, foreign inclusions, or other injurious defects. The conduit and fittings shall be as uniform as is commercially practical in color, opacity, density, and other physical properties.

##### 6.2 Dimensions:

6.2.1 Dimensions shall be determined in accordance with Test Method [D2122](#).

6.2.2 The dimensions and tolerances of the conduit shall be as specified in [Table 1](#).

6.2.3 *Lengths*—Conduit shall be supplied in lengths of 20 or 25 ft, or as otherwise agreed upon between the purchaser and the seller. A length shall be considered to be the overall length of the conduit, including integral bell, or coupling if attached, unless otherwise specified. Tolerance on length shall be  $\pm 1$  in. ( $\pm 25$  mm).

##### 6.2.4 Integral Bell Dimensions:

6.2.4.1 Two systems of fit for integral bells are in common use. Unless otherwise specified, the manufacturer may employ either of them.

<sup>3</sup> Supporting data have been filed at ASTM International Headquarters and may be obtained by requesting Research Report RR:F17-1002.

**TABLE 1 Conduit Dimensions and Tolerances, in.**

Nominal Size	Average Outside Diameter	Tolerance on		Minimum Wall Thickness <sup>A</sup>										
		Average	Out-of-Round <sup>B</sup>	Minimum Modulus 400 000 psi					Minimum Modulus 500 000 psi					
				EB-20	EB-35	DB-60	DB-100	DB-120	EB-20	EB-35	DB-60	DB-100	DB-120	
1	1.315	±0.005	0.060	—	—	—	—	0.060	—	—	—	—	—	0.060
1½	1.900	±0.006	0.060	—	—	0.060	—	0.065	—	—	—	—	—	0.060
2	2.375	±0.006	0.060	—	0.060	0.065	—	0.083	0.060	—	0.060	—	—	0.077
3	3.500	±0.008	0.060	0.067	0.082	0.100	0.121	0.127	0.061	0.076	0.092	0.112	0.118	0.118
3½	4.000	±0.008	0.100	0.078	0.095	0.115	0.138	0.147	0.072	0.088	0.107	0.128	0.136	0.136
4	4.500	±0.009	0.100	0.089	0.109	0.131	0.155	0.166	0.082	0.100	0.121	0.145	0.154	0.154
5	5.563	±0.010	0.100	0.112	0.136	0.164	0.192	0.205	0.103	0.126	0.152	0.179	0.191	0.191
6	6.625	±0.011	0.100	0.135	0.164	0.196	0.229	0.244	0.125	0.152	0.182	0.213	0.227	0.227

<sup>A</sup> Tolerance on wall thickness is +12, -0 % or +0.030, -0.000 in. whichever is greater.

<sup>B</sup> "Out-of-round" is defined as maximum diameter minus minimum diameter.

6.2.4.2 *Interference Fit System*—The dimensions and tolerances listed in Columns A and B of Table 1 in Specification D2466 provide a satisfactory interference fit system between pipe and socket.

6.2.4.3 *Clearance Fit System*—The dimensions and tolerances listed in Table 2 of this specification provide a satisfactory clearance fit system.

6.2.5 The wall thickness of integral bells and sweeps shall be considered satisfactory if formed from conduit which meets the minimum requirements of this specification.

6.2.6 Socket depths for integral bells shall conform to the requirements listed in Table 2.

6.2.7 Integral belled ends shall be centered to provide a visible shoulder around the entire circumference.

6.2.8 The inside diameters of spigot ends shall be chamfered as shown in Fig. 1.

6.2.9 *Fittings and Sweep Dimensions:*

6.2.9.1 The dimensions and types of conduit fittings shall be as specified in Tables 3-17.

6.2.9.2 Conduit fittings shall be capable of passing a ball ¼ in. (6 mm) less in diameter than the nominal size of the conduit.

6.2.9.3 The dimensions of sweeps and bends shall be as specified in Table 17. Sweeps and bends shall be made from DB-60 or DB-120 conduit. Sweeps made from DB-60 conduit are intended for use with EB-20 and DB-60 conduit. Sweeps made from DB-120 conduit are intended for use with EB-35 and DB-120 conduit.

6.3 *Minimum Pipe Stiffness:*

6.3.1 The minimum pipe stiffness ( $F/\Delta y$ ) values for conduit shall be in conformance with Table 18, when tested in accordance with 8.3. Three specimens shall be tested, all shall meet the requirements.

6.3.2 *Referee Test*—The minimum pipe stiffness ( $F/\Delta y$ ) values shall be in accordance with Table 18 when tested in accordance with Test Method D2412 at 5 % deflection.

6.4 *Impact Strength*—The minimum drop weight impact strength values for conduit shall be as listed in Table 19, when tested in accordance with 8.1.

6.4.1 The impact test is a quality control test, to be performed at the time of manufacture.

6.5 *Joint Tightness (Referee Test)*—The joints shall not leak when tested in accordance with 8.2.

6.6 *Extrusion Quality*—The conduit shall not flake or disintegrate when tested in accordance with Test Method D2152.

6.7 *Bond*—For pipe produced by the coextrusion process, that is, pipe containing two or more concentric layers, the bond between the layers shall be strong and uniform. It shall not be possible to separate any two layers with a probe or point of a knife blade so that the layers separate cleanly so the probe or knife blade moves freely between the layers. Nor shall separation of bond occur between layers during testing performed under the requirements of this specification.

**TABLE 2 Belled End Dimensions (Clearance Fit System), in.**

Nominal Size	Average Entrance Diameter	Average Bottom Diameter	Tolerance on Diameters	Out-of-Round Tolerance <sup>A</sup>	Socket Depth	
					min	max
1	1.331	1.320	±0.005	0.060	1.000	1.750
1½	1.921	1.906	±0.006	0.060	1.375	2.125
2	2.400	2.381	±0.006	0.060	1.750	2.500
3	3.538	3.508	±0.008	0.060	2.875	3.625
3½	4.041	4.008	±0.008	0.100	3.125	3.875
4	4.544	4.509	±0.009	0.100	3.375	4.125
5	5.614	5.573	±0.010	0.100	4.000	4.750
6	6.687	6.636	±0.011	0.100	5.000	5.750

<sup>A</sup> "Out-of-round" is defined as maximum diameter minus minimum diameter.

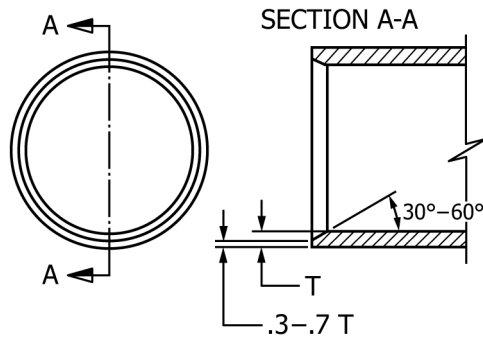

FIG. 1 Chamfer Detail

TABLE 3 Types of Conduit Fittings

1. Couplings
2. Domed caps
3. Flat caps
4. Fittings plugs
5. Tapered plugs
6. Bends (5, 22½, 30, 45, and 90°)
7. Sweeps (5, 22½, 30, 45, and 90°)
8. Angle Couplings (5°)
9. Fiber conduit adapters
10. Cement-asbestos conduit adapters
11. Water-tight expansion couplings
12. Spigot-ended reducers
13. Socket end-bells

TABLE 4 Fittings Socket Dimensions, in.

NOTE 1—Thermofomed fittings may employ the dimensions listed in Table 4, or the dimensions listed in Table 2 for integral bell ends.

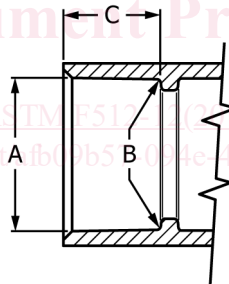

Nominal Size	Dimension A Average Entrance Diameter	Dimension B Average Bottom Diameter	Tolerance on Diameters	Out-of- Round Tolerance	Dimension C Minimum Socket Depth
2	2.393	2.369	±0.006	0.012	1.125
3	3.515	3.492	±0.008	0.015	1.594
3½	4.015	3.992	±0.008	0.015	1.687
4	4.515	4.491	±0.009	0.015	1.750
5	5.593	5.553	±0.010	0.030	1.937
6	6.658	6.614	±0.011	0.030	2.125

## 7. Conditioning

7.1 *Referee Testing*—When conditioning is required for referee tests, condition the specimens in accordance with Procedure A in Methods D618 at  $23 \pm 2^\circ\text{C}$  and  $50 \pm 5\%$  relative humidity for not less than 40 h prior to test. Conduct tests under the same conditions of temperature and humidity, unless otherwise specified.

### 7.2 Quality Control:

7.2.1 For quality control tests, condition specimens for a minimum of 3 h in air, or 1 h in liquid at  $23 \pm 2^\circ\text{C}$  (70 to 77°F). Test the specimens at  $23 \pm 2^\circ\text{C}$  without regard to relative humidity.

7.2.2 For the impact test, condition specimens for at least 30 min at 0 to 1.6°C (32 to 35°F).

TABLE 5 Coupling Dimensions, in.

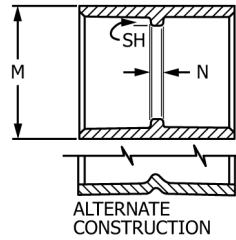

Nominal Size	M, max	SH, max	N, min
1	1 <sup>13</sup> / <sub>64</sub>	0.070	1/ <sub>16</sub>
1½	2 <sup>9</sup> / <sub>32</sub>	0.070	1/ <sub>16</sub>
2	2 <sup>47</sup> / <sub>64</sub>	0.075	3/ <sub>32</sub>
3	3 <sup>31</sup> / <sub>32</sub>	0.076	7/ <sub>64</sub>
3½	4½	0.087	7/ <sub>64</sub>
4	5 <sup>1</sup> / <sub>32</sub>	0.097	7/ <sub>64</sub>
5	6¼	0.118	9/ <sub>64</sub>
6	7½	0.140	9/ <sub>64</sub>

TABLE 6 5° Angle Couplings, in.

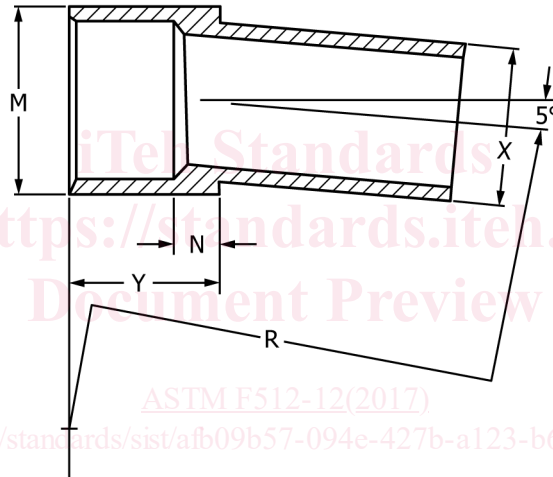

Nominal Size	M, max	N, min	X and Tolerance	Y, min	Bend R
2	2 <sup>9</sup> / <sub>16</sub>	1.50	2.375 ± 0.006	2.62	30
3	3 <sup>23</sup> / <sub>32</sub>	1.55	3.500 ± 0.008	3.14	36
4	4 <sup>5</sup> / <sub>16</sub>	1.39	4.500 ± 0.009	3.14	36
5	5 <sup>59</sup> / <sub>64</sub>	2.25	5.563 ± 0.010	4.19	48
6	7 <sup>1</sup> / <sub>64</sub>	3.12	6.625 ± 0.011	5.24	60

## 8. Test Methods

8.1 *Impact Resistance*—Test and evaluate five specimens, each  $6 \pm \frac{1}{16}$  in. ( $150 \pm 2$  mm) long, in accordance with Test Method D2444, using a 20-lb Tup B, and the flat plate (Holder B). When testing is performed at temperatures above 0°C, no more than 15 s shall elapse from the time of removal of the specimen from the conditioning medium until completion of that test. Specimens may be positioned with a random surface uppermost, but must be located so that the contact point is centered. All five specimens shall pass. If one specimen fails, test another five specimens: nine out of ten specimens passing shall be acceptable.

8.2 *Joint Tightness (Referee Test)*—Cement a section of conduit to a bell, using the manufacturer’s recommendations or, in their absence, the methods described in Practice D2855. Unless otherwise specified, allow the assembly to stand for at least 6 h. Then subject the assembly to an internal pressure of at least 25 psi (170 kPa), using water as the test medium. Maintain the pressure for at least 1 h. There shall be no leakage.

8.3 *Pipe Stiffness*—Determine the pipe stiffness ( $F/\Delta y$ ) at 5 % deflection of inside diameter, as described in Test Method D2412. Test three specimens each  $6 \pm \frac{1}{16}$  in. ( $150 \pm 2$  mm) long. Place each specimen so that the minimum wall thickness is uppermost

TABLE 7 Domed Cap Dimensions, in.



Nominal Size	W, max	M, max
2	2 <sup>3</sup> / <sub>32</sub>	2 <sup>13</sup> / <sub>16</sub>
3	3	4 <sup>3</sup> / <sub>32</sub>
3½	3½	4 <sup>5</sup> / <sub>8</sub>
4	3 <sup>31</sup> / <sub>64</sub>	5 <sup>13</sup> / <sub>64</sub>
5	4 <sup>27</sup> / <sub>64</sub>	6¼
6	5 <sup>7</sup> / <sub>32</sub>	7 <sup>25</sup> / <sub>64</sub>

TABLE 8 Flat Cap Dimensions, in.

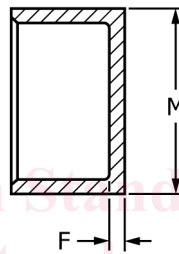

Nominal Size	F, min	M, max
2	1 <sup>9</sup> / <sub>32</sub>	2 <sup>35</sup> / <sub>64</sub>
3	1/16	3 <sup>45</sup> / <sub>64</sub>
3½	5/64	4 <sup>7</sup> / <sub>32</sub>
4	3/32	4¾
5	3/32	5 <sup>53</sup> / <sub>64</sub>
6	1/8	6 <sup>61</sup> / <sub>64</sub>

TABLE 9 Fitting Plug Dimensions, in.

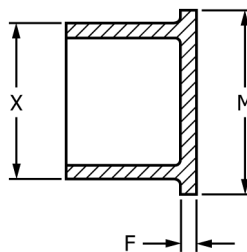

Nominal Size	M, max	F, min	X and Tolerance
2	2 <sup>19</sup> / <sub>32</sub>	2 <sup>3</sup> / <sub>64</sub>	2.375 ± 0.006
3	3 <sup>21</sup> / <sub>32</sub>	2 <sup>3</sup> / <sub>64</sub>	3.000 ± 0.008
3½	4 <sup>9</sup> / <sub>32</sub>	2 <sup>3</sup> / <sub>64</sub>	3.500 ± 0.008
4	4 <sup>25</sup> / <sub>32</sub>	2 <sup>3</sup> / <sub>64</sub>	4.500 ± 0.009
5	5 <sup>27</sup> / <sub>32</sub>	1 <sup>3</sup> / <sub>32</sub>	5.563 ± 0.010
6	Not Manufactured		

(adjacent to the top bearing plate). Measure the vertical inside diameter before compressing the specimen. Compress the specimen at the rate of ½ in. (13 mm)/min, and record the load at the point where the vertical inside diameter is equal to 95 % of the original inside diameter of the specimen.